

Chip Bead (CIC/CIS Series)



The CIC, CIS Series can be used in high current owing to their low DC resistance. They can match power lines to a maximum of 6A DC

General Features

- Smallest beads used in high current. (CIC: ~ 3A, CIS : ~ 6A)

Applications

- Suppression of noise in power line

Part Numbering

CI	C	10	J	121	N	C
①	②	③	④	⑤	⑥	⑦

① SAMSUNG MULTILAYER CHIP INDUCTOR/BEADS

② SERIES CODE

CODE	DESCRIPTION OF CODE
C	Chip Bead for High Current (max. 3.0A)
S	Chip Bead for Super High Current (max. 6.0A)

③ DIMENSION

CODE	DIMENSION(L×W)
05	1.0×0.5
10	1.6×0.8
21	2.0×1.25
31	3.2×1.6
32	3.2×2.5
41	4.5×1.6
43	4.5×3.2

④ MATERIAL CODE

CODE	DESCRIPTION OF CODE
P	Broad impedance, especially suppresses noise in the 10~200MHz range
J	Suppresses noise in the 100~300MHz range

⑤ NOMINAL IMPEDANCE

There are three digits representing impedance. The first 2 digits are showing figures and the other one is for the number of zero.

example)

CODE	IMPEDANCE
601	$60 \times 10^1 = 600 \Omega$
100	$10 \times 10^0 = 10 \Omega$

⑥ THICKNESS OPTION

CODE	DESCRIPTION OF CODE
N	Standard thickness
A	Thinner than standard thickness
B	Thicker than standard thickness
V	Internally vertical electrode structure

⑦ PACKAGE TYPE

CODE	DESCRIPTION OF CODE
C	Paper taping type
E	Embossed (Plastic) taping type

APPEARANCE AND DIMENSION

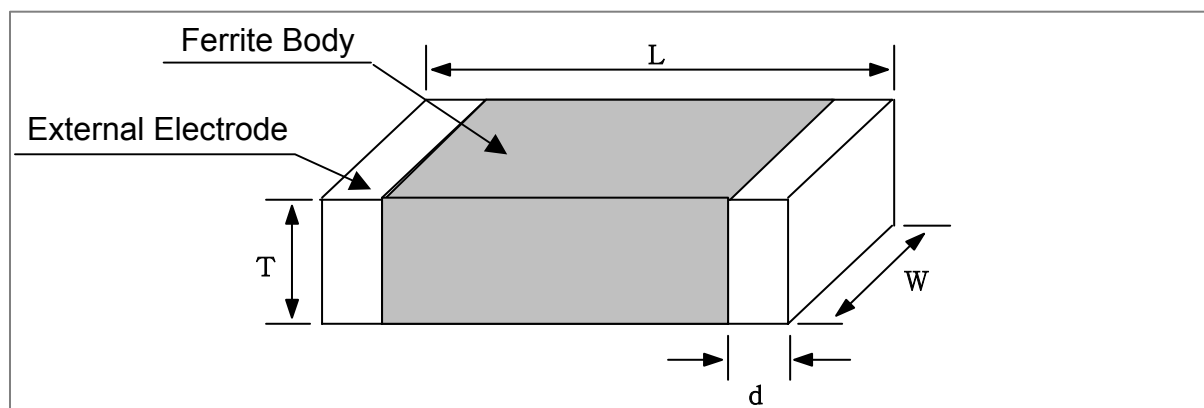

SIZE CODE	L	W	t	d
05	1.0 ± 0.05	0.5 ± 0.05	0.5 ± 0.05	0.25 ± 0.1
10	1.6 ± 0.15	0.8 ± 0.15	0.8 ± 0.15	0.3 ± 0.2
21	2.0 ± 0.2	1.25 ± 0.2	0.9 ± 0.2	0.5+0.2,-0.3
31	3.2 ± 0.2	1.6 ± 0.2	1.1 ± 0.2	0.5+0.2,-0.3
32	3.2 ± 0.2	2.5 ± 0.2	1.3 ± 0.2	0.5 ± 0.3
41	4.5 ± 0.2	1.6 ± 0.2	1.6 ± 0.2	0.5 ± 0.3
43	4.5 ± 0.2	3.2 ± 0.2	1.5 ± 0.2	0.5 ± 0.3

CHARACTERISTIC LINE UP

● CIC 1005(0402) Type

Part No.	Thickness [mm]	Impedance [Ω]± 25% @100MHz	DC Resistance [Ω] MAX	Rated Current [mA] MAX
CIC05P300	0.80 ± 0.15	30	0.05	1000
CIC05J600	0.80 ± 0.15	60	0.1	1000

We can provide custom product to meet customers need in addition to these products.

Test equipment : HP4291A + HP16193A

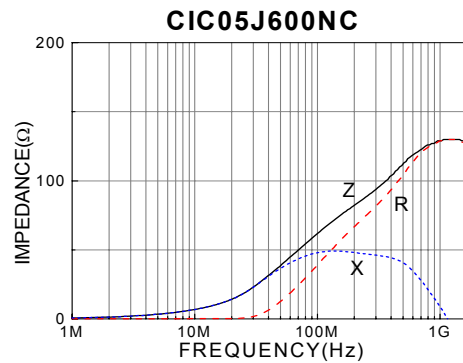
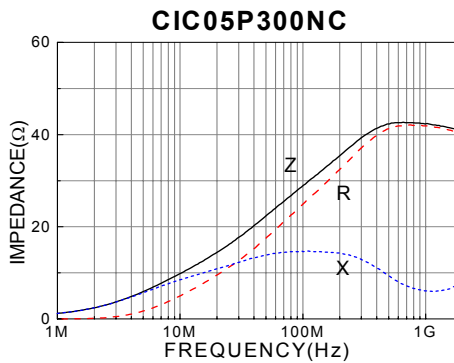

● CIC 1608(0603) Type

Part No.	Thickness [mm]	Impedance [Ω]± 25% @100MHz	DC Resistance [Ω] MAX	Rated Current [mA] MAX
CIC10P300	0.80 ± 0.15	30	0.1	1000
CIC10P600	0.80 ± 0.15	60	0.1	1000
CIC10P121	0.80 ± 0.15	120	0.10	750
CIC10P221	0.80 ± 0.15	220	0.15	750
CIC10J600	0.80 ± 0.15	60	0.1	1000
CIC10J121	0.80 ± 0.15	120	0.15	1000
CIC10J221	0.80 ± 0.15	220	0.15	800

We can provide custom product to meet customers need in addition to these products.

Test equipment : HP4291A + HP16193A

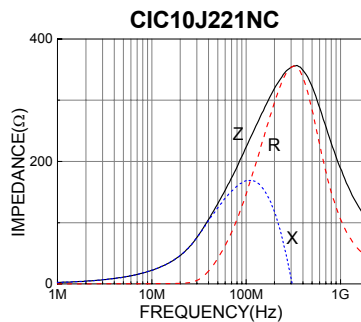
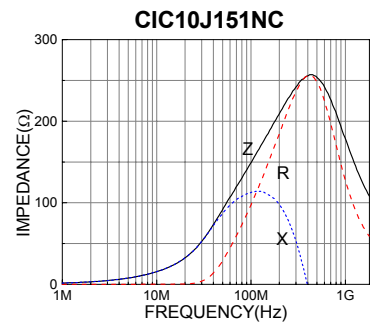
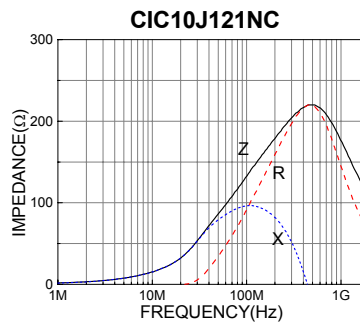
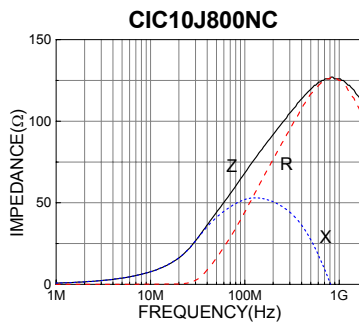
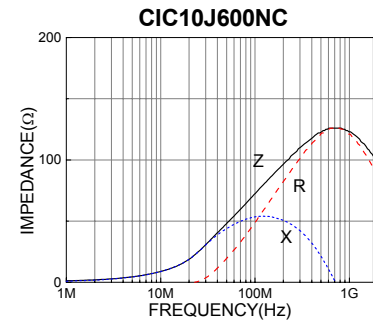
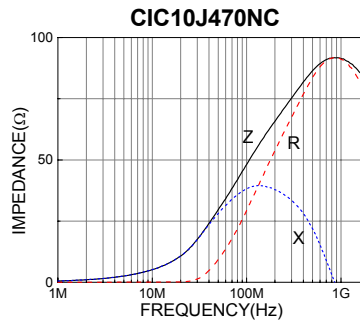
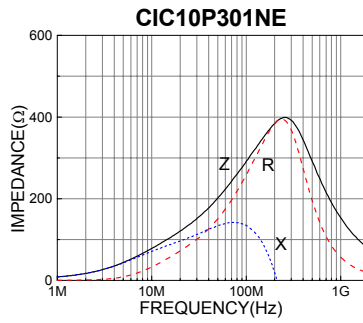
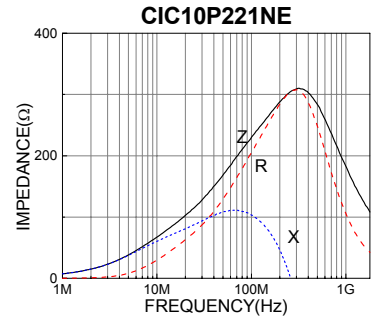
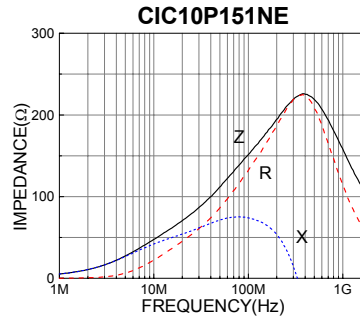
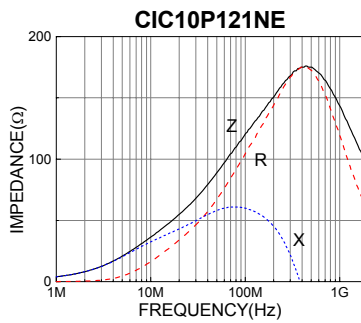
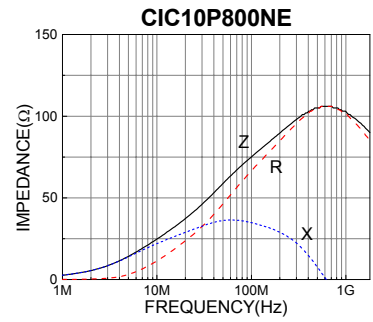
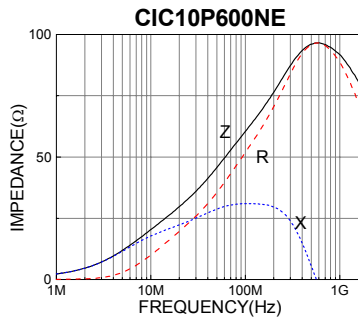
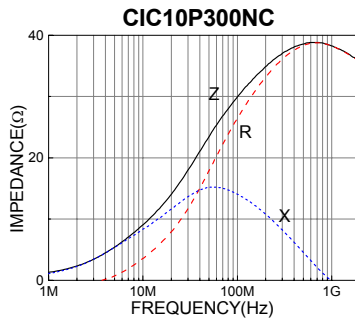

CIC/CIS Series

● CIC 2012 (0805) Type

Part No.	Thickness [mm]	Impedance [Ω] \pm 25% @100MHz	DC Resistance [Ω] MAX	Rated Current [mA] MAX
CIC21P110	0.90 \pm 0.2	11	0.05	3000
CIC21P300	0.90 \pm 0.2	30	0.05	3000
CIC21P600	0.90 \pm 0.2	60	0.05	2500
CIC21P121	0.90 \pm 0.2	120	0.05	2000
CIC21P221	0.90 \pm 0.2	220	0.05	2000
CIC21J600	0.90 \pm 0.2	60	0.03	2500
CIC21J121	0.90 \pm 0.2	120	0.05	2000
CIC21J221	0.90 \pm 0.2	221	0.05	1500
CIC21J301	0.90 \pm 0.2	300	0.1	1500
CIC21J471	0.90 \pm 0.2	470	0.08	1500
CIC21J601	0.90 \pm 0.2	600	0.15	1000

We can provide custom product to meet customers need in addition to these products.

Test equipment : HP4291A + HP16193A

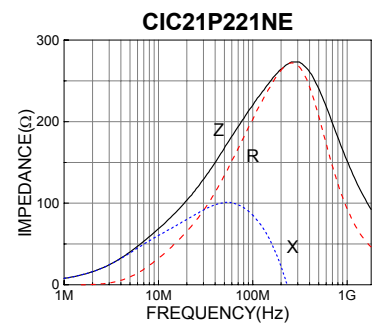
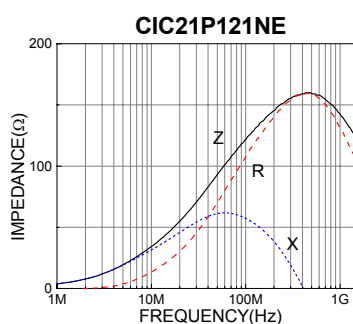
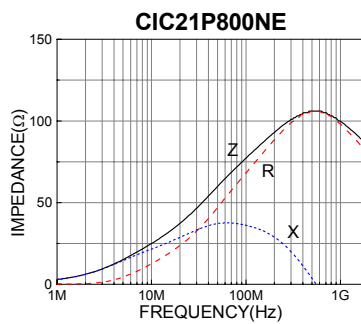
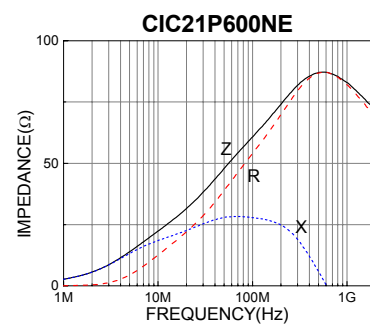
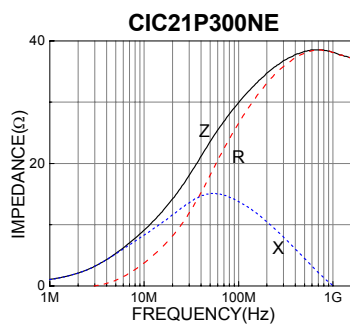
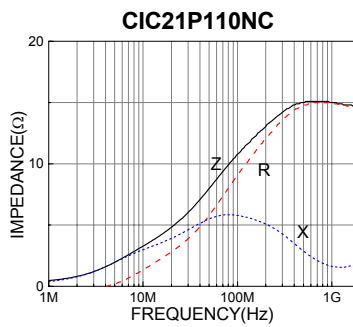

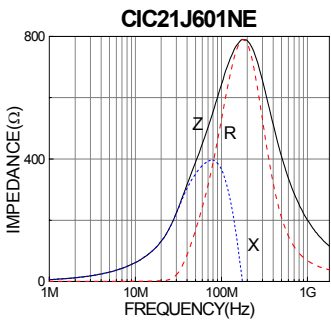
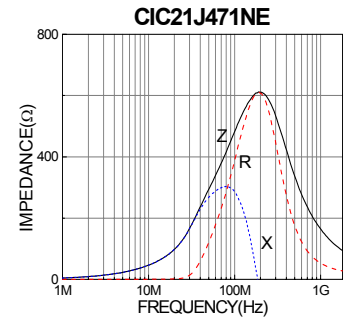
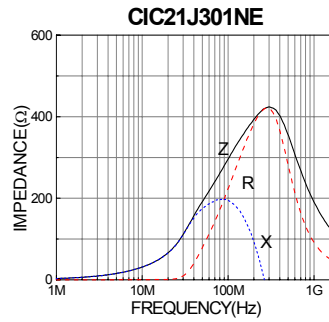
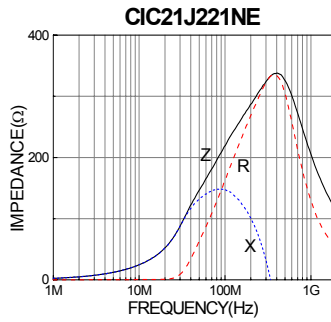
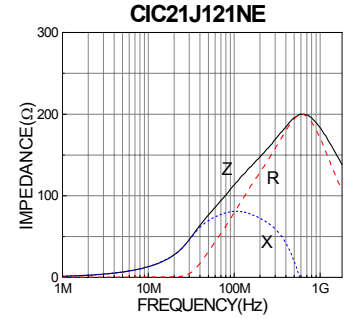
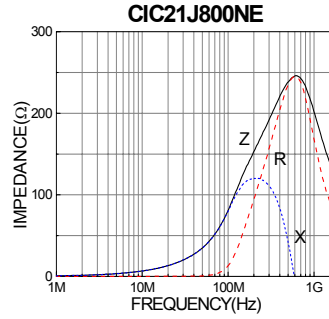
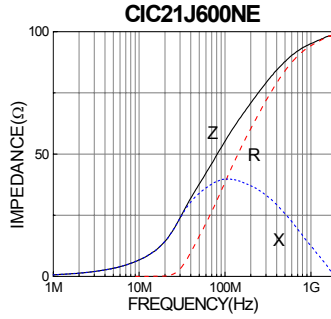

● CIB / CIM 3216(1206) Type

Part No.	Thickness [mm]	Impedance [Ω] \pm 25% @100MHz	DC Resistance [Ω] MAX	Rated Current [mA] MAX
CIC31P300	1.1 \pm 0.2	30	0.03	3000
CIC31P500	1.1 \pm 0.2	50	0.03	3000
CIC31P700	1.1 \pm 0.2	70	0.05	3000
CIC31P121	1.1 \pm 0.2	120	0.05	2000
CIC31P221	1.1 \pm 0.2	220	0.05	2000
CIC31P301	1.1 \pm 0.2	300	0.05	2000
CIC31P471	1.1 \pm 0.2	470	0.07	1500
CIC31J300	1.1 \pm 0.2	30	0.02	3000
CIC31J500	1.1 \pm 0.2	50	0.02	3000
CIC31J121	1.1 \pm 0.2	120	0.03	3000
CIC31J241	1.1 \pm 0.2	240	0.05	2000
CIC31J301	1.1 \pm 0.2	300	0.05	2000
CIC31J471	1.1 \pm 0.2	470	0.05	2000
CIC31J601	1.1 \pm 0.2	600	0.05	2000

We can provide custom product to meet customers need in addition to these products.

Test equipment : HP4291A + HP16193A

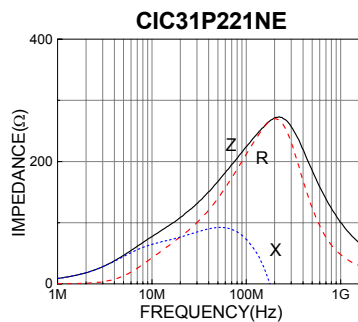
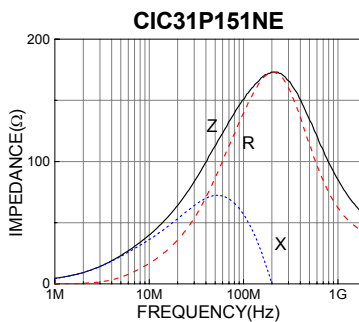
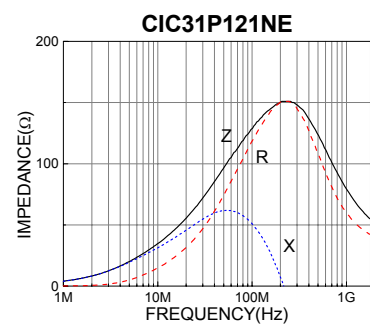
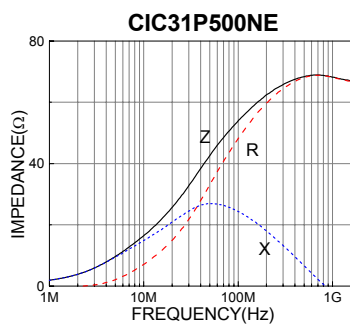
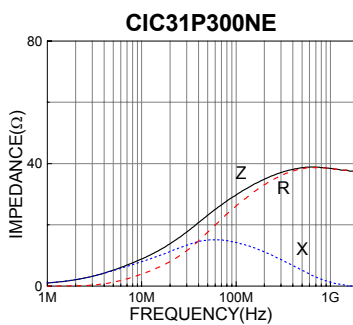

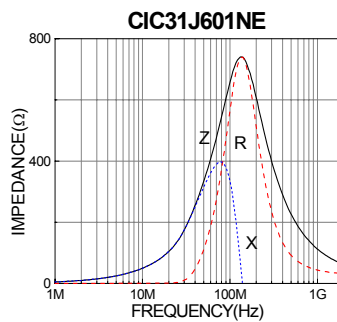
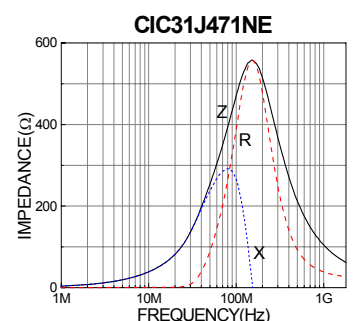
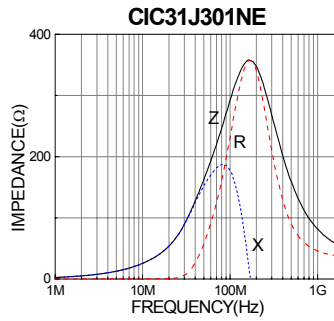
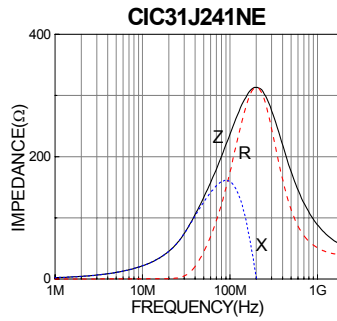
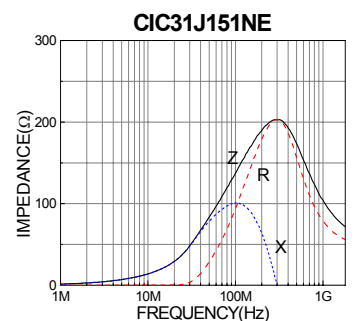
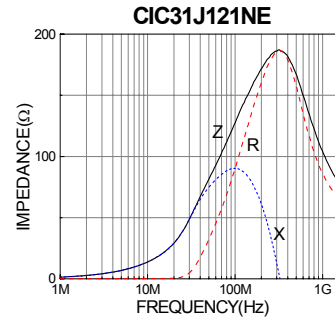
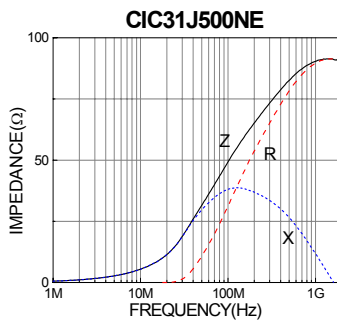
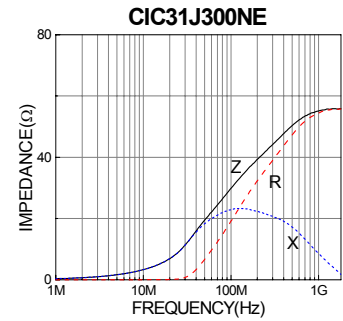
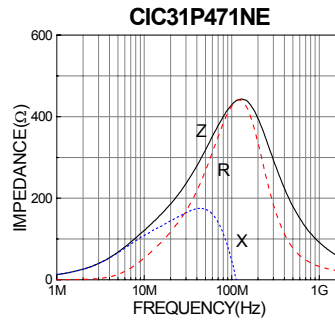
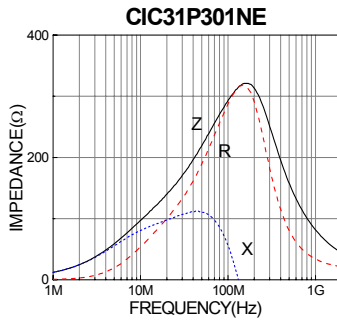

CIC/CIS Series

● **CIC4516 (1806) Type**

Part No.	Thickness [mm]	Impedance [Ω] \pm 25% @100MHz	DC Resistance [Ω] MAX	Rated Current [mA] MAX
CIC41P600	1.6 \pm 0.2	60	0.02	3000
CIC41P800	1.6 \pm 0.2	80	0.03	3000
CIC41P121	1.6 \pm 0.2	120	0.05	2500
CIC41P221	1.6 \pm 0.2	220	0.05	2000
CIC41P301	1.6 \pm 0.2	300	0.05	2000
CIC41P471	1.6 \pm 0.2	470	0.05	2000
CIC41P601	1.6 \pm 0.2	600	0.08	1500
CIC41J400	1.6 \pm 0.2	40	0.02	3000
CIC41J800	1.6 \pm 0.2	80	0.02	3000
CIC41J121	1.6 \pm 0.2	120	0.03	3000
CIC41J221	1.6 \pm 0.2	220	0.04	2500
CIC41J301	1.6 \pm 0.2	300	0.04	2500
CIC41J471	1.6 \pm 0.2	470	0.04	2500
CIC41J601	1.6 \pm 0.2	600	0.04	2500

We can provide custom product to meet customers need in addition to these products.

Test equipment : HP4291A + HP16193A

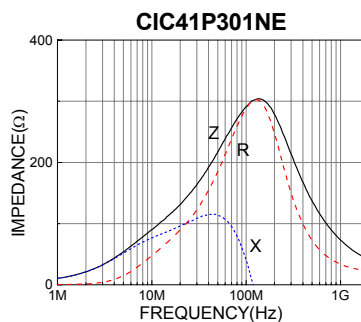
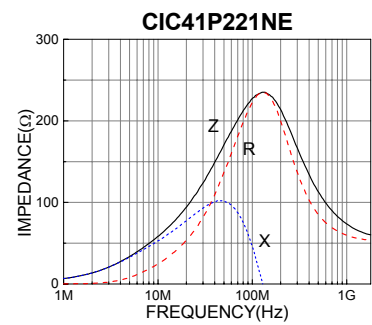
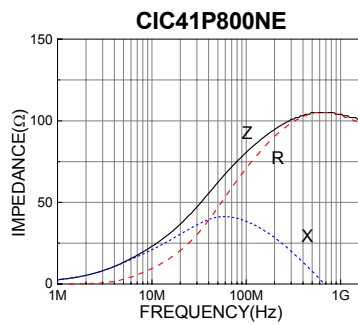
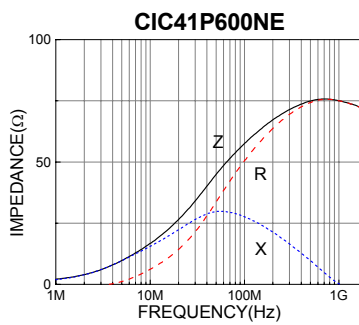

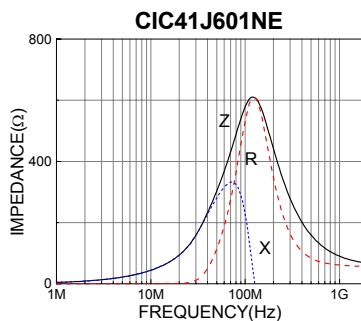
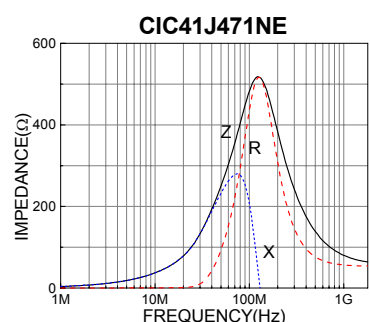
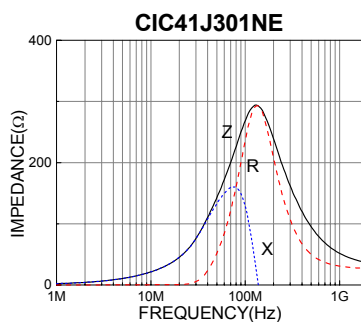
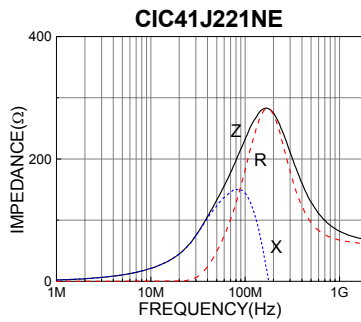
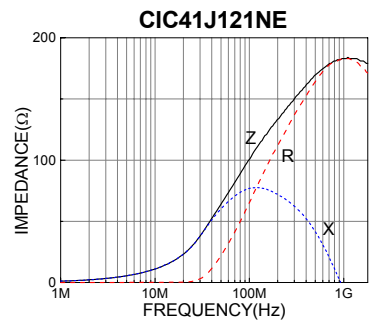
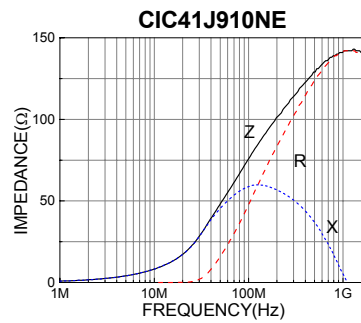
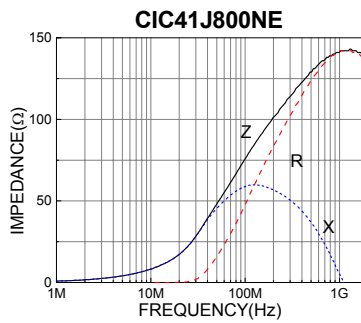
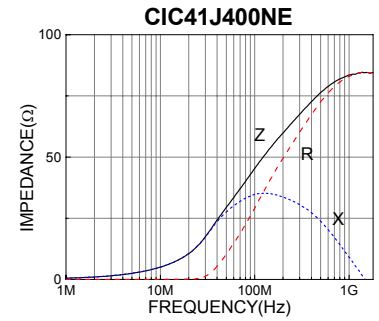
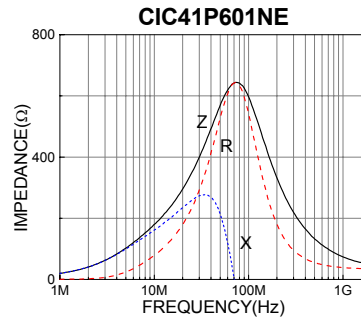
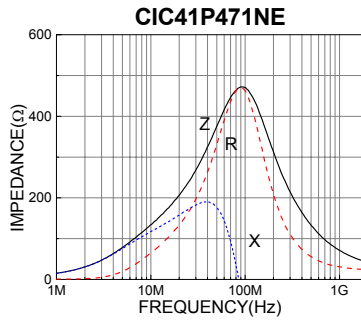

● CIC4532 (1812) Type

Part No.	Thickness [mm]	Impedance [Ω] \pm 25% @100MHz	DC Resistance [Ω] MAX	Rated Current [mA] MAX
CIC43P300	1.5 \pm 0.2	30	0.03	3000
CIC43P700	1.5 \pm 0.2	70	0.03	3000
CIC43P121	1.5 \pm 0.2	120	0.03	3000
CIC43P221	1.5 \pm 0.2	220	0.05	2000
CIC43P301	1.5 \pm 0.2	300	0.05	2000
CIC43P471	1.5 \pm 0.2	470	0.05	2000
CIC43P601	1.5 \pm 0.2	600(at 50MHz)	0.05	3000
CIC43J300	1.5 \pm 0.2	30	0.02	3000
CIC43J121	1.5 \pm 0.2	120	0.03	3000
CIC43J301	1.5 \pm 0.2	300	0.04	3000
CIC43J471	1.5 \pm 0.2	470	0.04	3000
CIC43J601	1.5 \pm 0.2	600	0.04	3000

We can provide custom product to meet customers need in addition to these products.

Test equipment : HP4291A + HP16193A

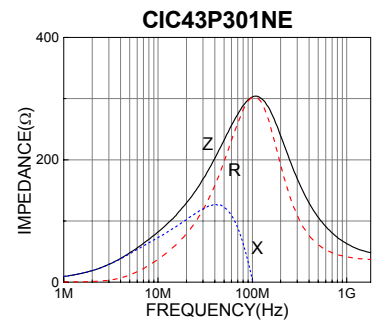
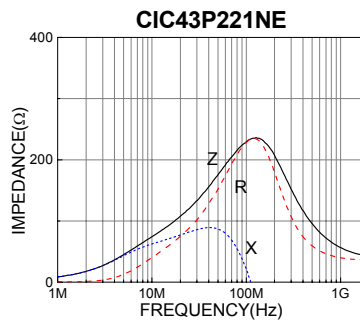
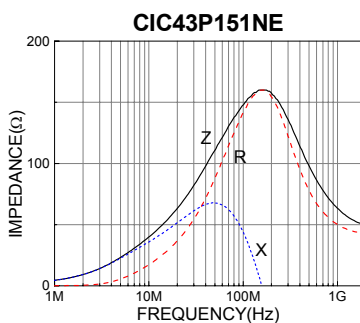
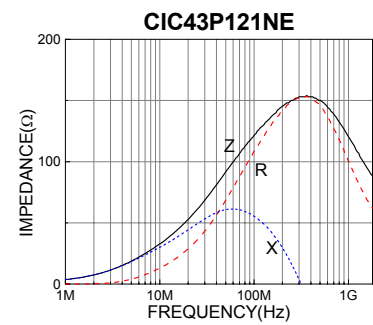
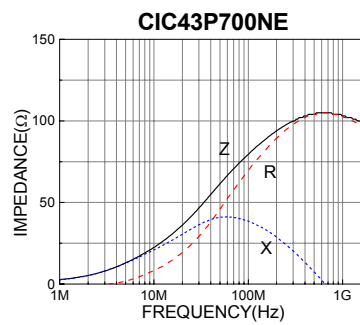
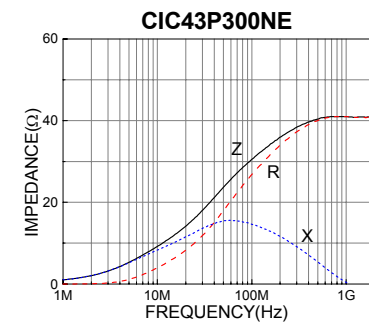

CIC/CIS Series

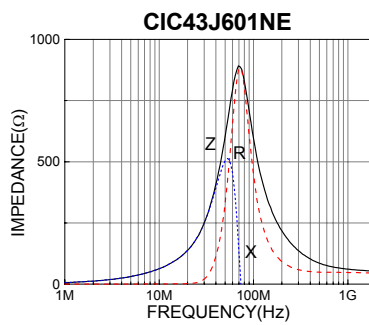
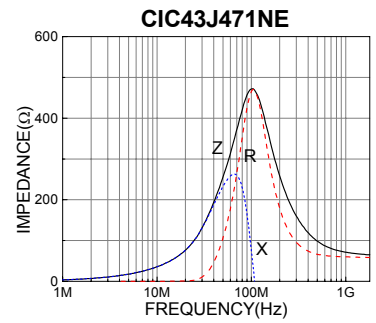
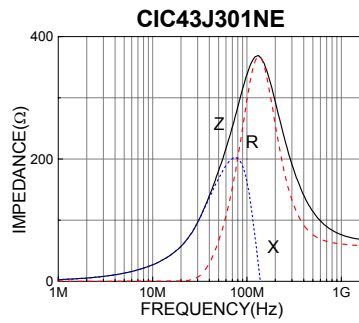
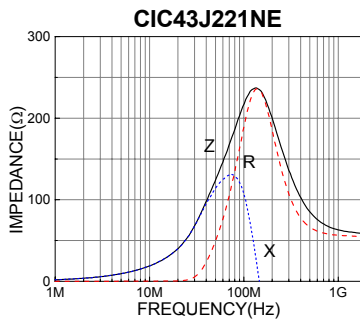
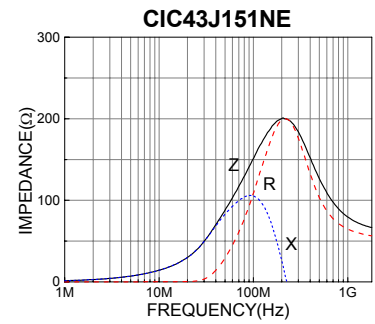
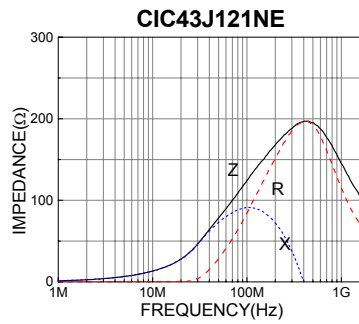
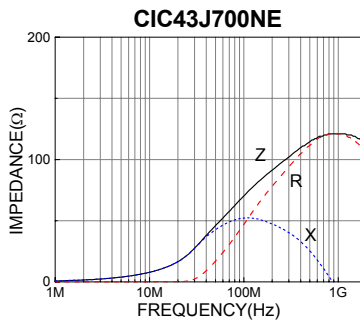
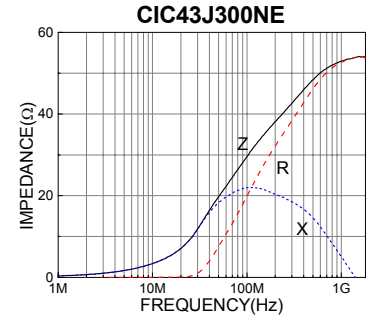
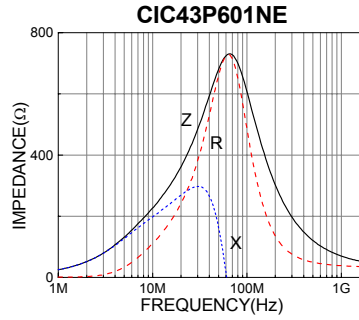
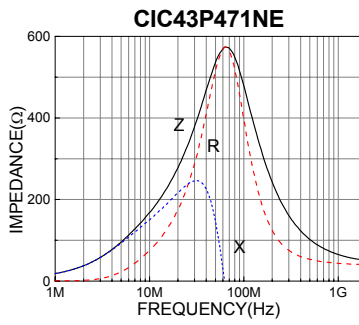

CIC/CIS Series

● **CIS Series**

Part No.	Thickness [mm]	Impedance [Ω] \pm 25% @100MHz	DC Resistance [Ω] MAX	Rated Current [mA] MAX
CIS10J300	0.8 \pm 0.15	30	0.01	6000
CIS21J121	1.25 \pm 0.2	120	0.02	5000
CIS32P520	1.3 \pm 0.2	52	0.01	6000
CIS32J121	1.3 \pm 0.2	120	0.02	5000
CIS41P600	1.6 \pm 0.2	60	0.01	6000
CIS41J600	1.6 \pm 0.2	60	0.01	6000
CIS43P241	1.5 \pm 0.2	240	0.02	6000

We can provide custom product to meet customers need in addition to these products.

Test equipment : HP4291A + HP16193A

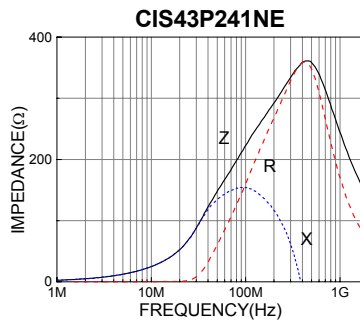
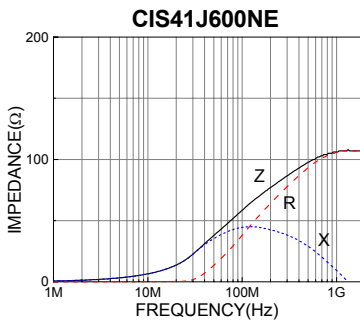
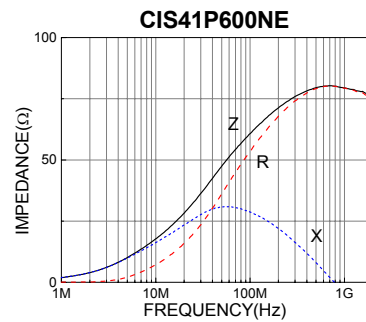
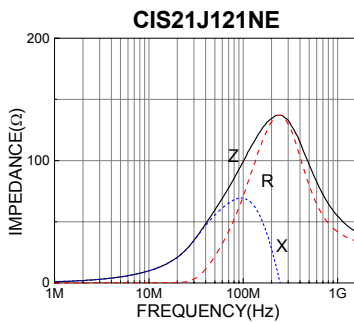
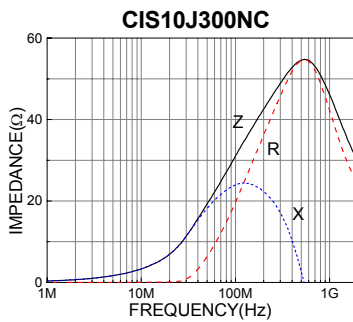

RELIABILITY TEST CONDITION

ITEM	PERFORMANCE			TEST CONDITION
	CIB/CIM	CIC/CIS	CIA	
1. OPERATING TEMPERATURE RANGE	-55 to +125℃		-25 to +85℃	-
2. STORAGE TEMPERATURE RANGE	-55 to +125℃		-40 to +85℃	-
3. IMPEDANCE	SEE THE SECTION OF ELECTRICAL PROPERTIES.			<ul style="list-style-type: none"> - MEASURING FREQUENCY : 100 ± 1MHz - MEASURING EQUIPMENT, TEST FIXTURE : HP4291A/B + HP16193A (CIB/CIM/CIC/CIS SERIES) HP4291A/B + HP16192A (CIA SERIES) - SOURCE OSC LEVEL : 30 mV
4. DC RESISTANCE	SEE THE SECTION OF ELECTRICAL PROPERTIES.			- MEASURING EQUIPMENT : HP4338A/B
5. HIGH TEMPERATURE TEST	NO APPARENT DAMAGE. IMPEDANCE CHANGE TO BE WITHIN ±30% TO THE INITIAL.		-	SOLDER THE SAMPLE ON PCB. EXPOSURE AT 125±3℃ FOR 500 HOURS. 1-2 HOURS EXPOSURE AT ROOM TEMPERATURE AND HUMIDITY PRIOR TO MEASUREMENT.
6. SOLDER HEAT RESISTANCE	NO MECHANICAL DAMAGE. REMAINING TERMINAL ELECTRODE : 70% MIN. IMPEDANCE CHANGE TO BE WITHIN ±30% TO THE INITIAL.	MORE THAN 75% OF THE TERMINAL SURFACE IS TO BE COVERED WITH SOLDER. NO MECHANICAL DAMAGE. IMPEDANCE VARIATION : WITHIN ±20%		AFTER BEING DIPPED IN FLUX FOR 4±1 SECONDS, AND PREHEATED AT 150~180℃ FOR 2~3 MIN , THE SPECIMEN SHALL BE IMMERSERD IN 60/40 TIN-LEAD ALLOY SOLDER AT 260±5℃ FOR 10 ± 0.5 SECONDS.
7. SOLDERABILITY	MORE THAN 95% OF TERMINAL ELECTRODE SHOULD BE SOLDERED NEWLY.	MORE THAN 90% OF TERMINAL ELECTRODE SHOULD BE SOLDERED NEWLY.		AFTER BEING DIPPED IN FLUX FOR 4±1 SECONDS, AND PREHEATED AT 150~180℃ FOR 2~3 MIN , THE SPECIMEN SHALL BE IMMERSERD IN SOLDER AT 230 ±5℃ (FOR CIA SERIES : 245 ±5℃) FOR 4±1 SECONDS.
8. THERMAL SHOCK	IMPEDANCE VARIATION : WITHIN 30%. NO MECHANICAL DAMAGE.	IMPEDANCE VARIATION : WITHIN 20%. NO MECHANICAL DAMAGE.		<ul style="list-style-type: none"> - CIB/CIM SERIES -55 ↔ +125℃, 30 MINUTES EACH. 5 CYCLES. - CIC/CIS SERIES -55 ↔ +125℃, 30 MINUTES EACH. 100 CYCLES. - CIA SERIES -40 ↔ +85℃, 30 MINUTES EACH. 5 CYCLES.

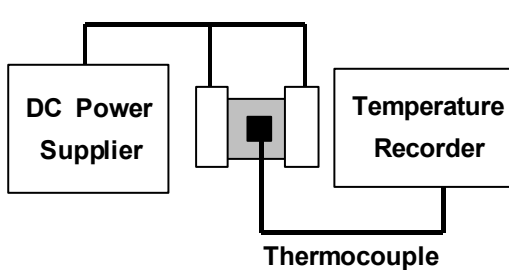
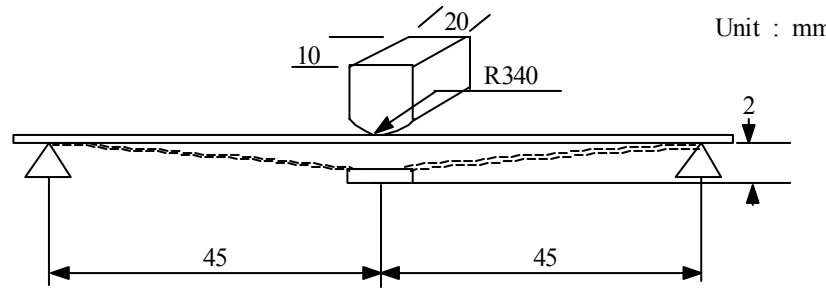
ITEM	PERFORMANCE			TEST CONDITION
	CIB/CIM	CIC/CIS	CIA	
9. MOISTURE LOADING TEST	IMPEDANCE VARIATION : WITHIN 30%. NO MECHANICAL DAMAGE.	IMPEDANCE VARIATION : WITHIN 20%. NO MECHANICAL DAMAGE.	IMPEDANCE VARIATION : WITHIN 20%. NO MECHANICAL DAMAGE.	- TEMPERATURE : $40\pm 2^{\circ}\text{C}$ - HUMIDITY : 90 ~ 95 %RH - DURATION : 500 ± 5 HRS. 1000 ± 12 HRS. (CIA SERIES) - CURRENT : RATED CURRENT
10. HIGH TEMPERATURE LOADING	IMPEDANCE VARIATION : WITHIN 30%. NO MECHANICAL DAMAGE.	IMPEDANCE VARIATION : WITHIN 20%. NO MECHANICAL DAMAGE.	IMPEDANCE VARIATION : WITHIN 20%. NO MECHANICAL DAMAGE.	- TEMPERATURE : $125\pm 3^{\circ}\text{C}$ $85\pm 3^{\circ}\text{C}$ (CIA SERIES) - DURATION : 500 ± 5 HRS. 1000 ± 12 HRS. (CIA SERIES) - CURRENT : RATED CURRENT
11. LOW TEMPERATURE RESISTANCE	IMPEDANCE VARIATION : WITHIN 30%. NO MECHANICAL DAMAGE.	IMPEDANCE VARIATION : WITHIN 20%. NO MECHANICAL DAMAGE.	IMPEDANCE VARIATION : WITHIN 20%. NO MECHANICAL DAMAGE.	- TEMPERATURE : $-55\pm 2^{\circ}\text{C}$ $-40\pm 2^{\circ}\text{C}$ (CIA SERIES) - DURATION : 500 ± 5 HRS. 1000 ± 12 HRS. (CIA SERIES)
12. RATED CURRENT	-	TEMPERATURE INCREASE - CIC : 40°C - CIS : 60°C	-	- APPLIED CURRENT : RATED CURRENT - TIME : 5 MIN. - ROOM TEMPERATURE : $25\pm 5^{\circ}\text{C}$ 
13. BENDING TEST	NO APPARENT DAMAGE.			SOLDER THE SAMPLE ON PCB, BEND TO 2mm.
	 <p>Unit : mm</p>			

CIC/CIS Series

ITEM	PERFORMANCE			TEST CONDITION																				
	CIB/CIM	CIC/CIS	CIA																					
14. VIBRATION TEST	IMPEDANCE VARIATION : WITHIN 30%. NO MECHANICAL DAMAGE.	IMPEDANCE VARIATION : WITHIN 20%. NO MECHANICAL DAMAGE.	IMPEDANCE VARIATION : WITHIN 20%. NO MECHANICAL DAMAGE.	APPLY VIBRATIONS IN EACH OF THE X, Y AND Z DIRECTIONS. - FREQUENCY : 10 ~ 55 ~ 10Hz - TOTAL AMPLITUDE : 1.52mm - TIME : 2 HRS. EACH (TOTAL 6 HRS.)																				
15. DROP TEST	IMPEDANCE VARIATION : WITHIN 30%. NO MECHANICAL DAMAGE.	IMPEDANCE VARIATION : WITHIN 20%. NO MECHANICAL DAMAGE.	IMPEDANCE VARIATION : WITHIN 20%. NO MECHANICAL DAMAGE.	DROP THE SAMPLE FROM A HEIGHT OF 1m TO CONCRETE GROUND 10 TIMES.																				
16. TERMINAL TEST	NO INDICATION OF PEELING SHALL OCCUR ON THE TERMINAL ELECTRODE.			<table border="1"> <thead> <tr> <th>SIZE</th> <th>W(Kgf)</th> <th>SIZE</th> <th>W(Kgf)</th> </tr> </thead> <tbody> <tr> <td>05</td> <td>0.5</td> <td>31 (CIA)</td> <td>0.5</td> </tr> <tr> <td>10</td> <td>0.5</td> <td>32</td> <td>1.0</td> </tr> <tr> <td>21</td> <td>0.5</td> <td>41</td> <td>1.0</td> </tr> <tr> <td>31</td> <td>1.0</td> <td>43</td> <td>1.0</td> </tr> </tbody> </table>	SIZE	W(Kgf)	SIZE	W(Kgf)	05	0.5	31 (CIA)	0.5	10	0.5	32	1.0	21	0.5	41	1.0	31	1.0	43	1.0
				SIZE	W(Kgf)	SIZE	W(Kgf)																	
05	0.5	31 (CIA)	0.5																					
10	0.5	32	1.0																					
21	0.5	41	1.0																					
31	1.0	43	1.0																					
<p>- APPLYING TIME : 10±1 SEC.</p>																								

CIC/CIS Series

PACKAGING

● CARDBOARD PAPER TAPE

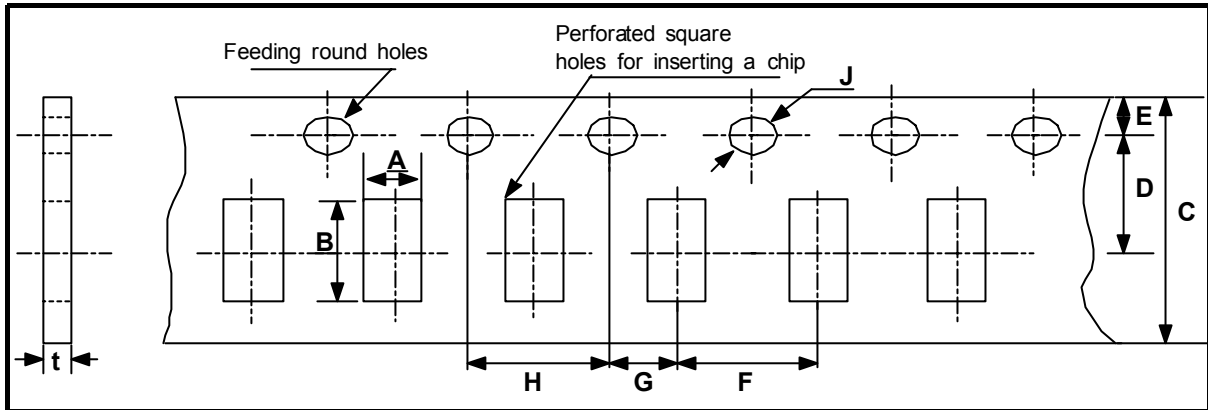

unit : mm

TYPE	A	B	C	D	E	F	G	H	J	t max.
05	0.65 ±0.1	1.15 ±0.1	8.0 ±0.2	3.5 ±0.05	1.75 ±0.1	2.0 ±0.05	2.0 ±0.1	4.0 ±0.1	Φ1.5 +0.1/-0	0.8
10	1.0 ±0.2	1.80 ±0.2				4.0 ±0.1				

● EMBOSED PLASTIC TAPE

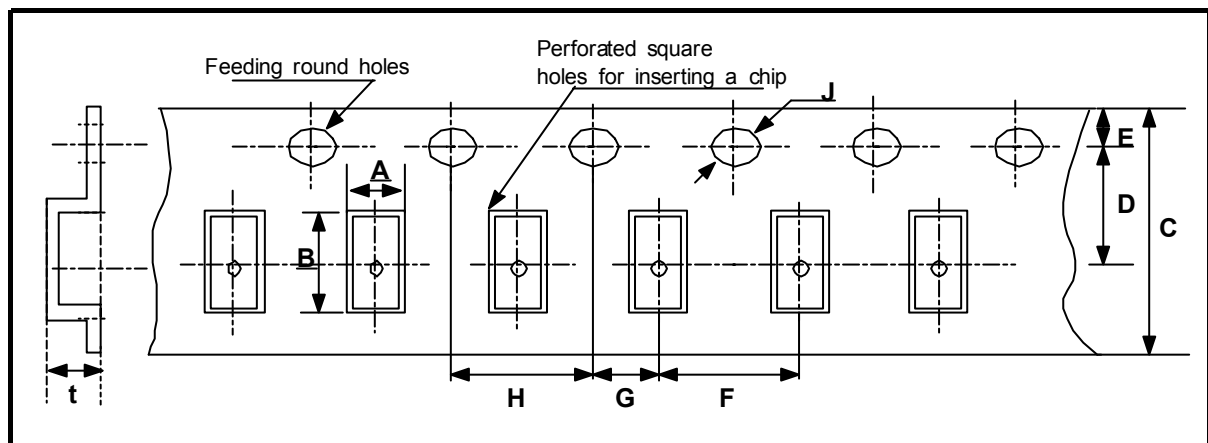

unit : mm

TYPE	A	B	C	D	E	F	G	H	J	t max.
21	1.50 ±0.2	2.3 ±0.2	8.0 ±0.3	3.5 ±0.05	1.75 ±0.1	4.0 ±0.1	2.0 ±0.1	4.0 ±0.1	Φ1.5 +0.1/-0	1.5
31	1.90 ±0.2	3.6 ±0.2								1.4
32	2.9 ±0.2	3.6 ±0.2	12.0 ±0.3	5.5 ±0.05	8.0 ±0.1	8.0 ±0.1	2.0 ±0.1	4.0 ±0.1	Φ1.5 +0.1/-0	1.55
41	1.90 ±0.2	4.9 ±0.2								1.8
43	3.5 ±0.2	±0.2	±0.3	±0.05	±0.1	±0.1	±0.1	±0.1	±0.1	1.8

● TAPING SIZE

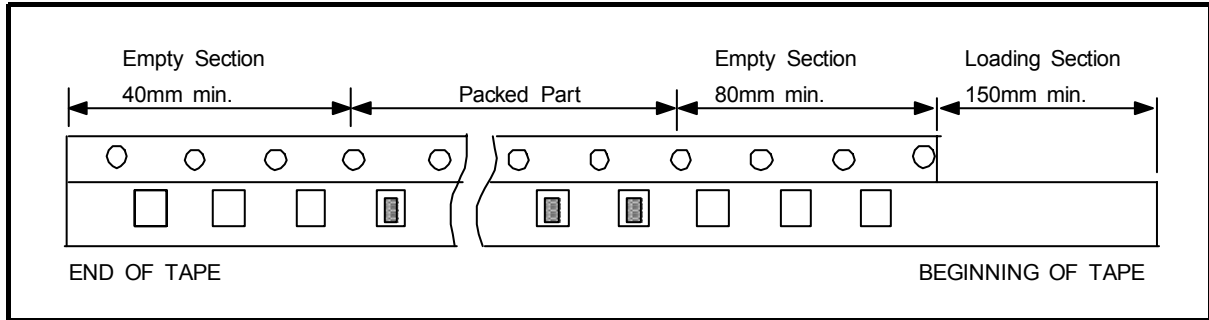

unit : pcs

Symbol	05	10	21	31	32	41	43
7" Reel	10,000	4,000	4,000	3,000	2,500	2,000	1,000

● REEL DIMENSION

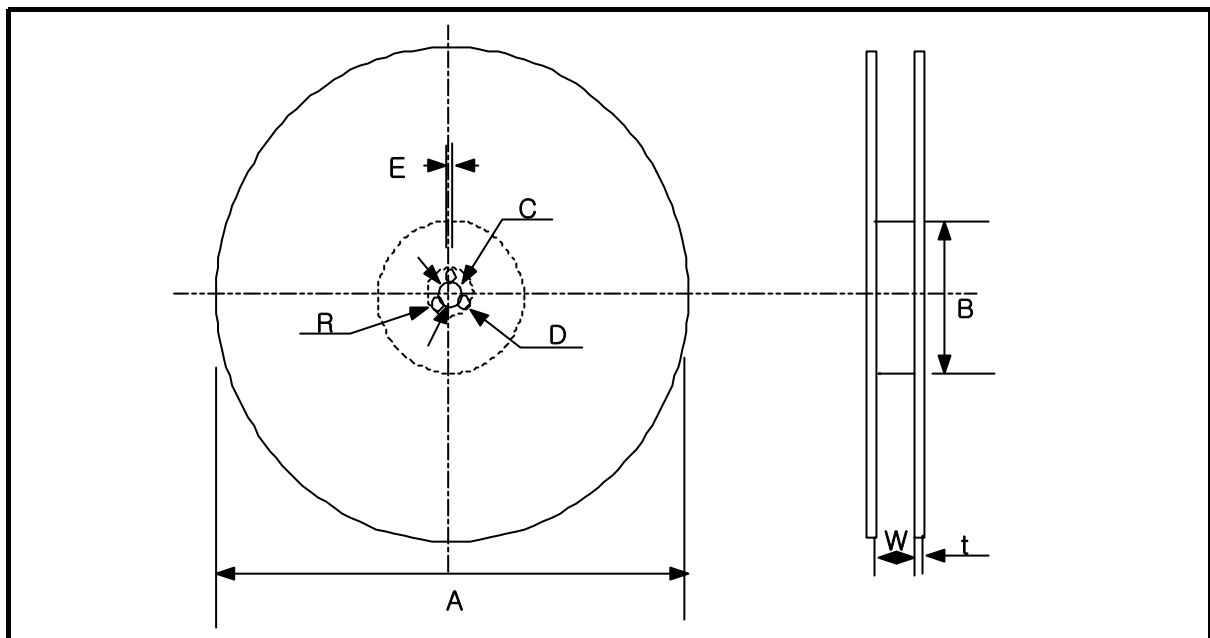

unit : mm

Tape Width	A	B	C	D	E	W	t	R
8 mm	$\phi 178 \pm 2.0$	$\phi 50 \pm 1.0$	$\phi 13 \pm 0.5$	21 ± 0.8	2.0 ± 0.5	10 ± 1.5	1.2 ± 0.5	1.0
12 mm						14 ± 1.5	2.0 ± 0.5	