

General Description

The EV0056 evaluation board is designed for backlights using white LEDs. It implements MPS' MP1518 fixed frequency step-up converter.

The MP1518 is a 6 pin thin SOT23 step up converter designed for driving up to 6 series white LEDs from a single cell Lithium Ion battery. The MP1518 uses current mode, fixed frequency architecture to regulate the LED current, which is measured through an external current sense resistor. It's low 100mV feedback voltage reduces power loss and improves efficiency. To prevent damage due to an open circuit condition, the OV pin monitors the output voltage and turns off the converter if an over-voltage condition is present.

The MP1518 includes under-voltage lockout, current limiting and thermal overload protection preventing damage in the event of an output overload. The MP1518 is available in a small 6 lead TSOT23 package.

Absolute Maximum Ratings

SW	-0.5V to 28V
All Other Pins except OV	-0.3V to 6.5V

Recommended Operating Conditions

IN Supply Voltage	2.5V to 6V
-------------------	------------

Features

- On Board Power MOSFET
- Drives up to 6 Series White LEDs
- Up to 86% Efficiency
- Over 1MHz Fixed Switching Frequency
- Open Load Shutdown
- Low 100mV Feedback Voltage
- Soft Start/PWM Dimming
- UVLO, Thermal Shutdown
- Internal Current Limit

Applications

- Cell Phones
- Handheld Computers and PDAs
- Digital Still and Video Cameras
- Small LCD Displays

Ordering Information

Board Number	MPS IC Number
EV0056	MP1518DJ

Figure 1: EV0056 Evaluation Board

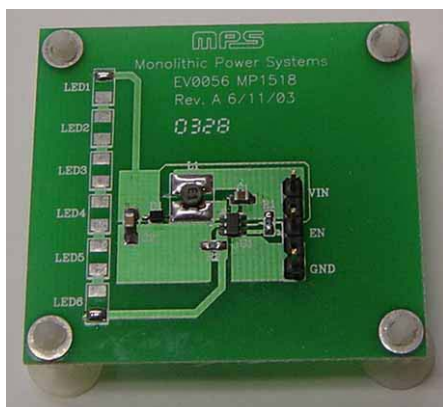

Actual Size = 1.9"X x 1.8"Y

Figure 2: EV0056 Schematic

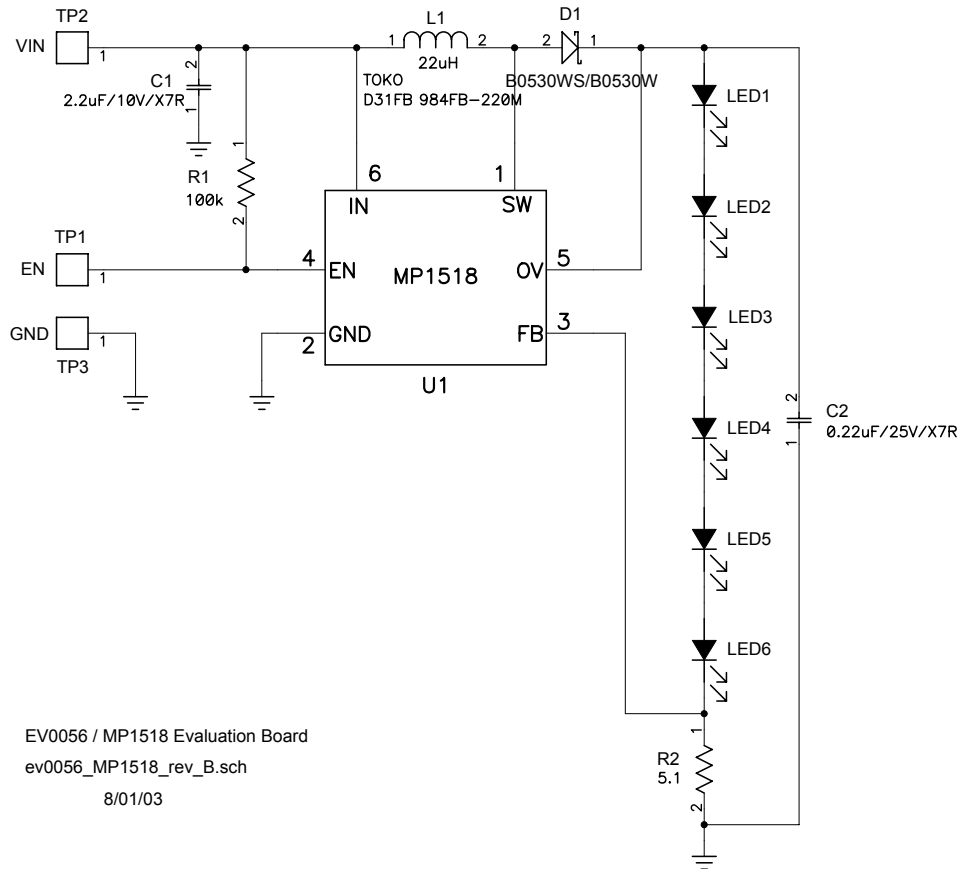

Table 1: EV0056 Bill of Materials

Component	Description	Manufacturer Part Number	Package	Qty
U1	White LED Driver	MP1518DJ	SOT23-6	1
C1	2.2µF, 10V, X7R	ANY	0805	1
C2	0.22µF, 25V, X7R	ANY	0805	1
D1	Schottky Diode	B0530WS/B0530W	SOD323	1
L1	22µH Inductor	TOKO D31FB 984FB-220M	SMD	1
R1	100KΩ	ANY	0603	1
R2	5.1Ω	ANY	0603	1
LED1 – LED6	White LED	ANY	1210	NS
			Total	7

*NS = No Stuff

Board Operation:

1. Solder LED1 – LED6 to board.
2. Connect positive and negative terminals of 2.5V to 6V power supply to VIN and GND pins respectively.
3. Drive EN high to turn on the MP1518, drive EN low to shut down the MP1518.
4. To use burst-mode brightness control, drive EN with a PWM signal.

Figure 3: Top Silk Layer

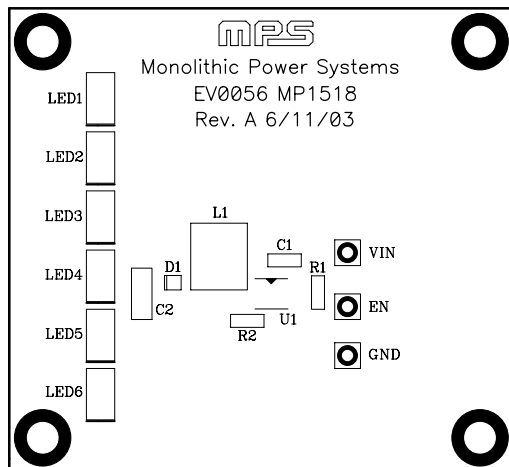

Figure 4: Top Layer

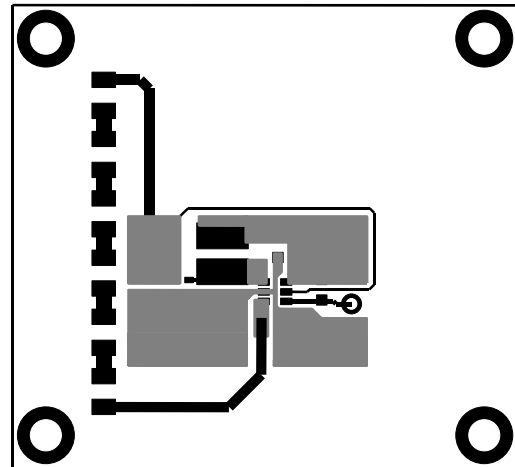

Figure 5: Bottom Silk Layer

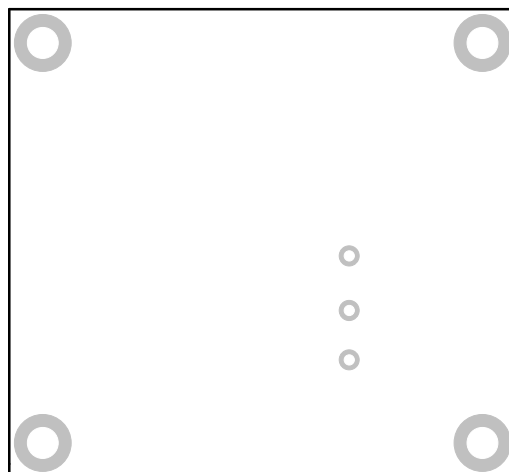
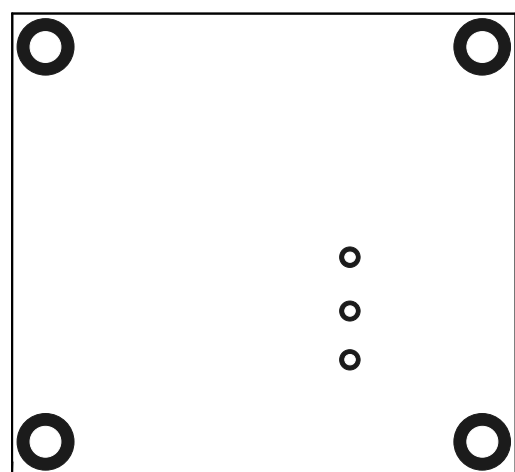

Figure 6: Bottom Layer



NOTICE: MPS believes the information in this document to be accurate and reliable. However, it is subject to change without notice. Please contact the factory for current specifications. No responsibility is assumed by MPS for its use or fit to any application, nor for infringement of patent or other rights of third parties.