

# **ST1114E / ST1114K / ST1114P**

---

**Version : A.011**

**Issue Date : 2003/09/26**

**File Name : SP-ST1114EKP-A.011.doc**

**Total Pages: 7**

*Double Coil Brushless*

*DC Motor Driver ( 1.8 to 16 Volts )*

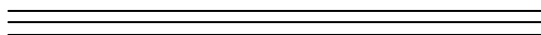

SILICON TOUCH TECHNOLOGY INC.  
新竹市科學園區展業一路九號七樓之一  
9-7F-1 Prosperity Road I Science-Based Industrial Park  
Hsinchu, Taiwan 300, R.O.C.  
Tel : 886-3-5645656 Fax : 886-3-5645626



## ST1114E / ST1114K / ST1114P

### Double Coil Brushless

### DC Motor Driver ( 1.8 to 16 Volts )

#### General Specifications

The devices are designed specifically for electronic commutation of double coil DC motor applications. They are intended to be used as an interface between a HALL effect latch and a double coil load. Each device includes a fan tachometer, a lock detection circuit to shut down the drivers for overheat prevention, and two drivers for sinking large load on a single silicon chip.

The fan tachometer is designed for fan speed output as open-drain output with a built-in pull-up resistor about  $100\text{K}\Omega$  and these devices are designed for different applications, ST1114E is for 4 poles fan application, ST1114K is for 8 poles fan application and ST1114P is for rotation detection output. With suitable output pull up resistance, this fan tachometer output can be used directly with bipolar or MOS logic for motor speed monitoring/control.

The output driver node "O1" will be "turned to sink" for  $V(\text{HIN}) = \text{logic low}$ . Similarly, the output node "O2" will be "turned to sink" for  $V(\text{HIN}) = \text{logic high}$ .

The devices also provide lock and auto-restart function without any timing capacitor. If the motor rotation is stalled by external force or obstacles, overdrive current ( or lock current ) may incur coil overheat/burning. To prevent coil overheat/burning, these devices incorporate lock detection circuit to shut down the drivers. After the motor locking is released, the drivers can be powered up using an automatic self-restart circuit. For 12V application, the drivers are shut down roughly 1 to 3 seconds after the motor is locked. After the drivers are shut down, the automatic self-restart circuit will try to power up the drivers every 1 to 3 seconds.

## Pin Assignment

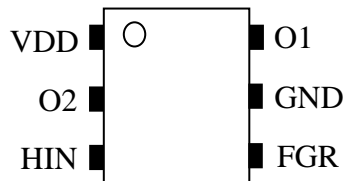

Pin NO.	Pin Name	Description
1	VDD	Power supply pin
2	O2	Output sinking pin
3	HIN	Input pin from Hall Latch IC
4	FGR	Output pin of fan tachometer (open-drained with an pull-up resistor about 100K $\Omega$ ) FG : ST1114E (The frequency is same with the HIN frequency. ) FG/2 : ST1114K (The frequency is the half HIN frequency.) RD : ST1114P (Rotation detection output)
5	GND	Ground pin
6	O1	Output sinking pin

## Features and Benefits

- Optimized for double coil Brushless DC Motor applications
- Wide operation range (1.8V ~ 16V )
- Lock detection and automatic self-restart
- Tachometer output or Rotation Detector Output  
FG output for ST1114E, FG/2 output for ST1114K, RD output for ST1114P
- Support for 3V/5V/12V supply voltage
- High output sinking capability
- Thin, small, highly reliable package (SOT-26)

## Absolute Maximum Ratings ( Unless otherwise noted, $T_A=25^{\circ}\text{C}$ )

Parameter	Symbol	Rating	Unit
Supply Voltage	$V_{DD}$	1.8 ~ 16	V
Input Voltage	$V_{IN}$	-0.4 ~ $V_{DD}+0.4$	V
Maximum Output Current	$I_{OUT}$	800	mA
Power Dissipation	$P_D$	0.35	W
Operating Temperature Range	$T_A$	-40 ~ 125	$^{\circ}\text{C}$
Storage Temperature Range	$T_S$	-65 ~ 150	$^{\circ}\text{C}$

\* Power dissipation and operating temperature must be concerned for lager current application.

**Electrical Characteristic** ( $T_A = 25^\circ\text{C}$  &  $V_{DD} = 12\text{ V}$ )

Characteristic	Sym.	Condition	Limit			Unit
			Min.	Typ.	Max.	
Supply Voltage	$V_{DD}$	Operating	1.8	12	16	V
Quiescent Current	$I_{DD}$	No load, All Inputs = 0V or $V_{DD}$	-	5	-	mA
HIN Input Terminal						
Input Voltage "H"	$V_{IH}$	-	$0.8 \cdot V_{DD}$	-	$V_{DD}$	V
Input Voltage "L"	$V_{IL}$	-	-0.4	-	$0.2 \cdot V_{DD}$	V
Input Current "H"	$I_{IH}$	$V_{HIN} = V_{DD}$	-	-	$\pm 5$	$\mu\text{A}$
Input Current "L"	$I_{IL}$	$V_{HIN} = 0\text{V}$	-	1.6	-	mA
O1/O2 Output Terminal ( $T_J = 25^\circ\text{C}$ )						
Output Voltage Low	$V_{OL}$	$I_{OUT} = 250\text{ mA}$	-	0.4	0.8	V
Output Current	$I_{OUT}$	$R_L = 60\ \Omega$	-	188	-	mA
TACHO Open-Drain Terminal ( $T_J = 25^\circ\text{C}$ )						
Output Leakage Current	$I_{Leak}$	$V_{FGO} = 12\text{V}$	-	-	5	$\mu\text{A}$
Output Current	$I_{FG}$	$V_{FGOL} = 0.4\text{V}$	10	-	-	mA
Output Voltage High	$V_{FGOH}$	-	-	-	15	V
Output Voltage Low	$V_{FGOL}$	$I_{FG} = 10\text{ mA}$	-	0.2	0.4	V
Automatic Self-Restart Circuit						
On Period	$T_{ON}$	-	-	156	-	ms
Duty Ratio	$R_{DR}$	$T_{OFF} / T_{ON}$	6	7	8	

## Truth Table

HIN	O1	O2	State
H	OFF	ON	Operation
L	ON	OFF	Operation
H/L	OFF	OFF	Lock protection
H	OFF	ON	Self restart*
L	ON	OFF	Self restart*

\*The motor will be powered up by turn on output drivers for a period about 156ms per 1.25sec (at VDD = 12V) through self-restart mechanism after the motor is locked.

## Block Diagram & Application Circuit

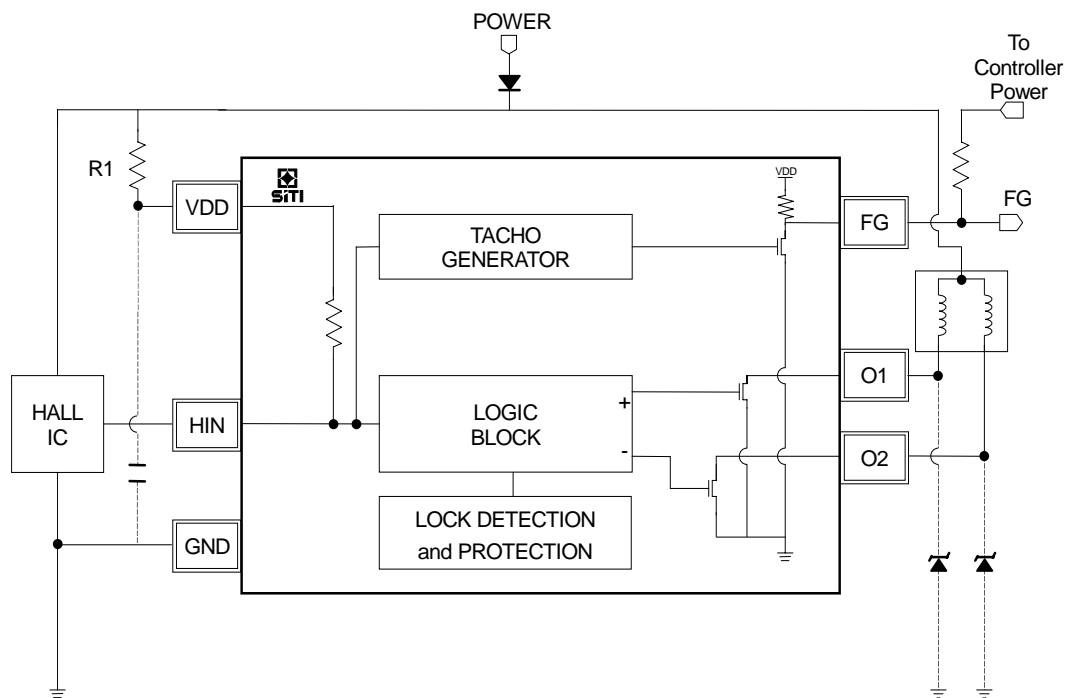

## Application Notes

- The FGR pin is an open-drained output with built-in pull-up resistor about 100K  $\Omega$  and outputs the same frequency with HIN pin for ST1114E, the half frequency of HIN pin for ST1114K, and rotation detection result for ST1114P. An additional resistor can be used to pull up the FGR voltage to the appropriate level which depends on the voltage level of the monitoring/control system. For the ST1114P, the output of RD is at logical low state when fan is operating and logical high state when fan is lock.
- The resistor R1 connected between system power and VDD of HALL IC and driver increase system stability. The suggestion value of R1 is about 75 $\Omega$  for 12V application.
- There is no requirement of the capacitor between VDD and GND in normal applications. The connection of this capacitance will increase stability of operation, special when the motor is operating at large current or low voltage.
- The power dissipated by the IC varies widely with the supply voltage, the output current, and loading. It is important to ensure the application does not exceed the allowable power dissipation of the IC package. The recommended *motor driver* power dissipation versus temperature is depicted as follows:

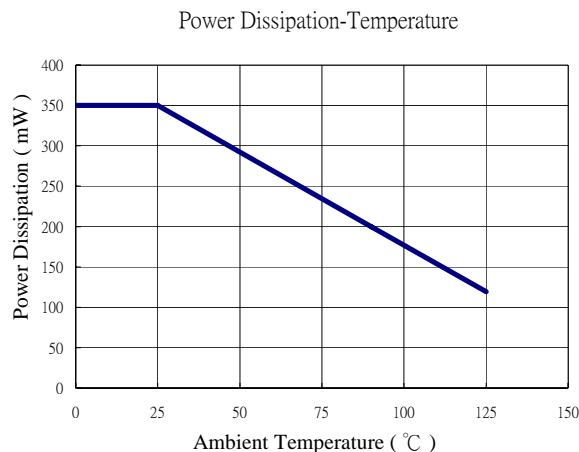

## Package Specifications ( SOT-26 )

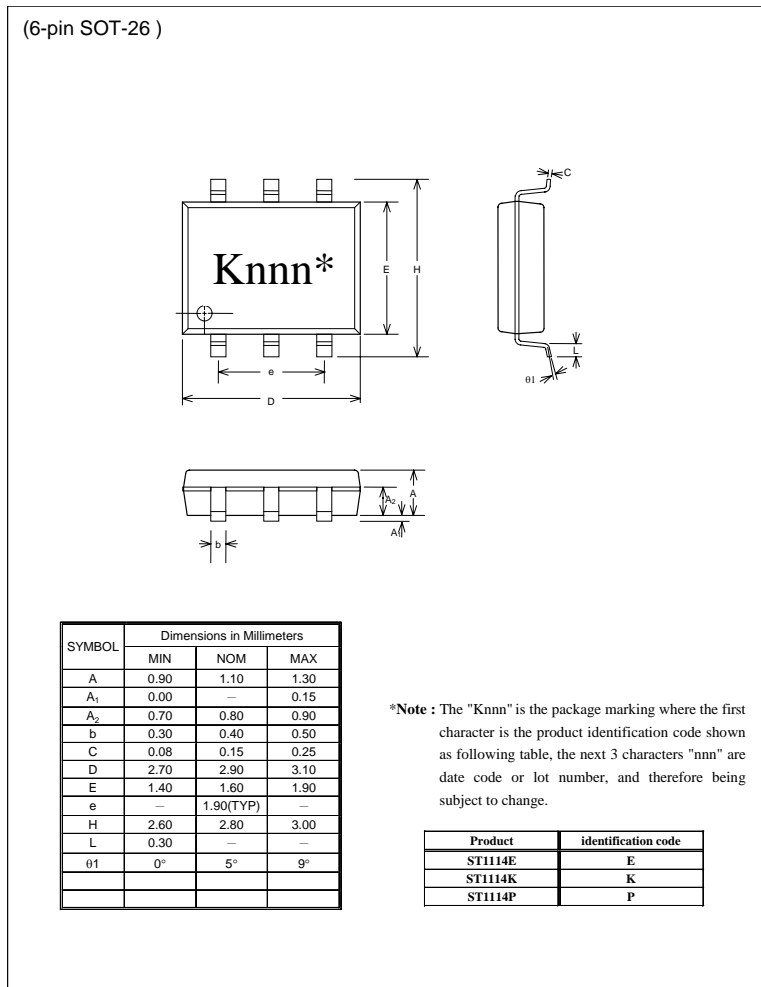

The products listed herein are designed for ordinary electronic applications, such as electrical appliances, audio-visual equipments, communication devices and so on. Hence, it is advisable that the devices should not be used in medical instruments, surgical implants, aerospace machinery, nuclear power control systems, disaster/crime-prevention equipments and the like. Misusing those products may directly or indirectly endanger human life, or cause injury and property loss.

Silicon Touch Technology, Inc. will not take any responsibilities regarding the misuse of the products mentioned above. Anyone who purchases any products described herein with the above-mentioned intention or with such misused applications should accept full responsibility and indemnify. Silicon Touch Technology, Inc. and its distributors and all their officers and employees shall defend jointly and severally against any and all claims and litigation and all damages, cost and expenses associated with such intention and manipulation.