

L, S- BAND SPDT SWITCH

DESCRIPTION

The μ PG158TB is a L-band SPDT (Single Pole Double Throw) GaAs FET switch which was developed for digital cellular, cordless telephone and other L, S-band wireless application. The device can operate from 500 MHz to 2.5 GHz, having the low insertion loss. It housed in an original 6-pin super minimold package that is smaller than usual 6-pin minimold easy to install and contributes to miniaturizing the system.

FEATURES

- Low Insertion Loss: $L_{INS} = 0.3$ dB TYP. @ $V_{CONT} = +3.0$ V/0 V, $f = 1$ GHz
 $L_{INS} = 0.4$ dB TYP. @ $V_{CONT} = +3.0$ V/0 V, $f = 2$ GHz
 $L_{INS} = 0.5$ dB TYP. @ $V_{CONT} = +3.0$ V/0 V, $f = 2.5$ GHz
- ★ High isolation: $ISL = 27$ dB TYP. @ $V_{CONT} = +3.0$ V/0 V, $f = 0.5$ to 2 GHz
- Small 6-pin super minimold package (Size: $2.0 \times 1.25 \times 0.9$ mm)

APPLICATIONS

- L, S-band digital cellular or cordless telephone
- PCS, WLAN, WLL and Bluetooth applications

ORDERING INFORMATION

Part Number	Marking	Package	Supplying Form
μ PG158TB-E3	G1M	6-pin super minimold	Embossed tape 8 mm wide. Pin 1, 2, 3 face to tape perforation side. Qty 3 kp/reel.

Remark To order evaluation samples, please contact your local NEC sales office. (Part number for sample order: μ PG158TB)

Caution The IC must be handled with care to prevent static discharge because its circuit is composed of GaAs MES FET.

The information in this document is subject to change without notice. Before using this document, please confirm that this is the latest version.
 Not all devices/types available in every country. Please check with local NEC representative for availability and additional information.

ABSOLUTE MAXIMUM RATINGS (T_A = +25 °C)

Parameter	Symbol	Ratings	Unit
Control Voltage 1, 2	V _{CONT1, 2}	-6.0 to +6.0 ^{Note}	V
Input Power	P _{in}	+28	dBm
Total Power Dissipation	P _{tot}	0.15	W
Operating Temperature	T _A	-45 to +85	°C
Storage Temperature	T _{stg}	-45 to +150	°C

Note Condition $2.5 \leq |V_{CONT1} - V_{CONT2}| \leq 6.0$ V

- Remarks 1.** Mounted on a 50 × 50 × 1.6 mm double copper clad epoxy glass PWB, T_A = +85 °C
2. Operation in excess of any one of these parameters may result in permanent damage.

PIN CONNECTIONS

Pin No.	Connection	Pin No.	Connection
1	OUT1	4	V _{CONT2}
2	GND	5	IN
3	OUT2	6	V _{CONT1}

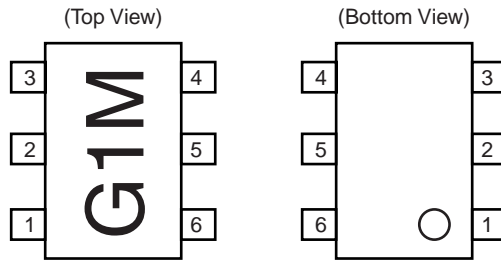

RECOMMENDED OPERATING CONDITIONS (T_A = +25 °C)

Parameter	Symbol	MIN.	TYP.	MAX.	Unit
Control Voltage (High)	V _{CONT}	+2.5	+3.0	+5.3	V
Control Voltage (Low)	V _{CONT}	-0.2	0	+0.2	V

ELECTRICAL CHARACTERISTICS

(Unless otherwise specified, T_A = +25 °C, V_{CONT1} = 3 V, V_{CONT2} = 0 V or V_{CONT1} = 0 V, V_{CONT2} = 3 V, Off chip DC blocking capacitors value; 51 pF)

Parameter	Symbol	Test Conditions	MIN.	TYP.	MAX.	Unit
Insertion Loss	L _{INS}	f = 0.5 to 1.0 GHz	–	0.3	0.55	dB
		f = 2.0 GHz	–	0.4	0.65	
		f = 2.5 GHz	–	0.5 ^{Note1}	–	
Isolation	ISL	f = 0.5 to 2.0 GHz	22	27	–	dB
		f = 2.5 GHz	–	23 ^{Note1}	–	
Input Return Loss	RL _{in}	f = 0.5 to 2.0 GHz	13	19	–	dB
Output Return Loss	RL _{out}	f = 0.5 to 2.0 GHz	13	19	–	dB
Input Power at 0.1 dB Compression Point ^{Note2}	P _{in(0.1 dB)}	f = 1.0 GHz, V _{CONT} = 3 V/0 V	–	23.0	–	dBm
Input Power at 1 dB Compression Point ^{Note2}	P _{in(1 dB)}	f = 1.0 GHz, V _{CONT} = 3 V/0 V	22.0	26.5	–	dBm
Switching Speed	t _{sw}		–	50	200	ns
Control Current	I _{CONT}	V _{CONT} = 3 V/0 V	–	0.5	10	μA

Notes 1. Characteristic for reference at 2.0 to 2.5 GHz

2. P_{in(0.1 dB)} or P_{in(1 dB)} is measured the input power level when the insertion loss increases more 0.1 dB or 1 dB than that of linear range. All other characteristics are measured in linear range.

Cautions 1. When the μPG158TB is used it is necessary to use DC blocking capacitors for No. 1 (OUT1), No.3 (OUT2) and No.5 (IN). The value of DC blocking capacitors should be chosen to accommodate the frequency of operation, band width, switching speed and the condition with actual board of your system.

The range of recommended DC blocking capacitor value is less than 100 pF.

2. The distance between IC's GND pin and ground pattern of substrate should be as shorter as possible to avoid parasitic parameters.

TYPICAL CHARACTERISTICS

TEST CONDITIONS: $V_{CONT} = 3 V/O V$, $P_{in} = 0 dBm$, $T_A = +25 °C$

★

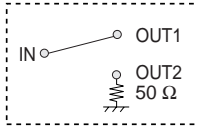

IN-OUT1 INPUT RETURN LOSS vs. FREQUENCY

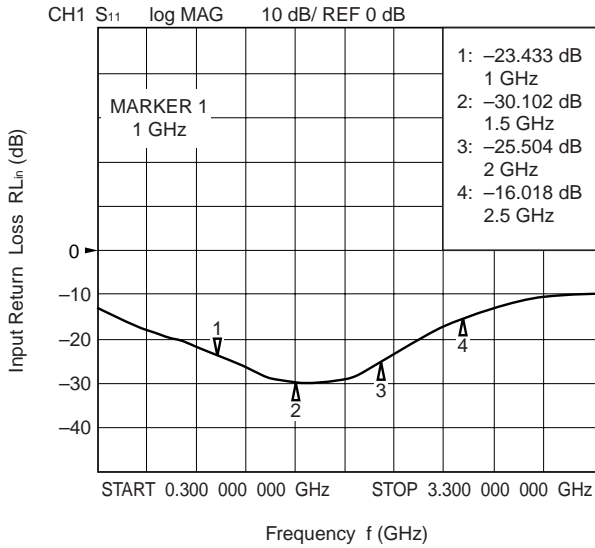

IN-OUT1 ISOLATION vs. FREQUENCY

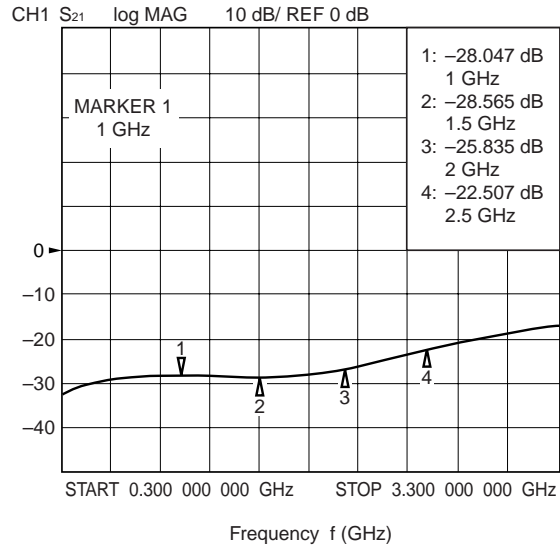

IN-OUT1 INSERTION LOSS vs. FREQUENCY

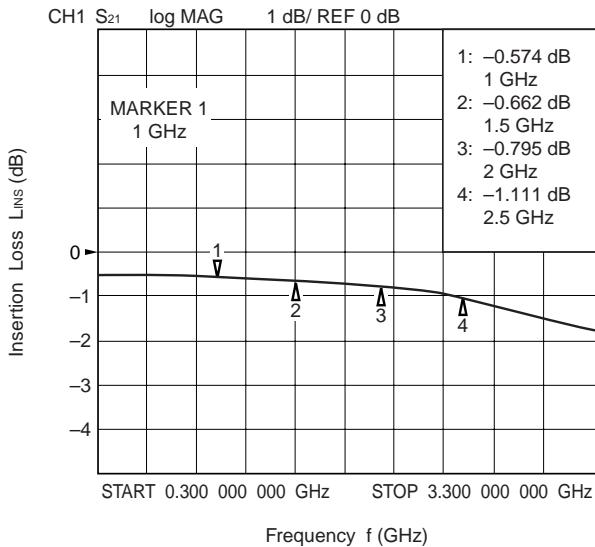

IN-OUT1 OUTPUT RETURN LOSS vs. FREQUENCY

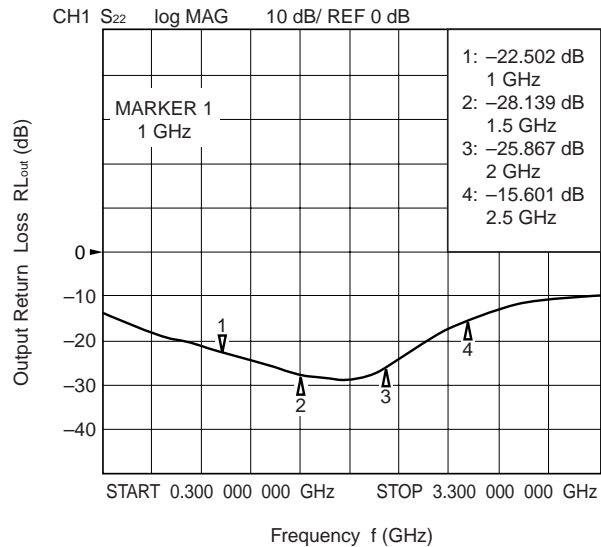

Caution This data is including loss of the test fixture.

TEST CIRCUIT

$T_A = +25\text{ }^\circ\text{C}$, $V_{\text{CONT1}} = +3\text{ V}$, $V_{\text{CONT2}} = 0\text{ V}$ or $V_{\text{CONT1}} = 0\text{ V}$, $V_{\text{CONT2}} = +3\text{ V}$, $f = 2\text{ GHz}$

Off chip DC blocking capacitors value: $C_0 = 51\text{ pF}$, $C_1 = 1000\text{ pF}$ (Bypass), Using NEC standard evaluation board

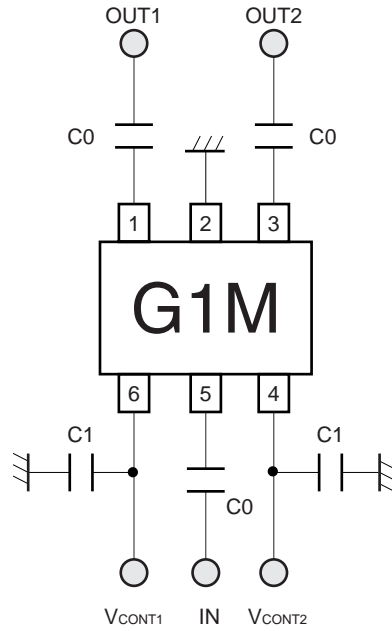

★ **EVALUATION BOARD**

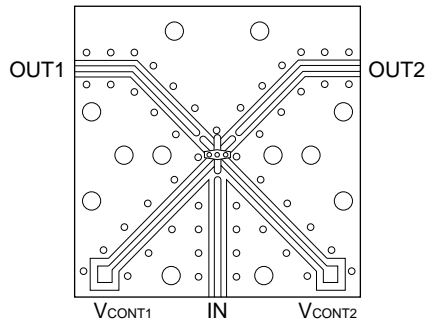

TRUTH TABLE OF SWITCHING BY CONDITION OF CONTROL VOLTAGE

		V _{CONT1}	
		V _{CONT(H)}	V _{CONT(L)}
V _{CONT2}	V _{CONT(H)}		
	V _{CONT(L)}		

PACKAGE DIMENSIONS

6 PIN SUPER MINIMOLD (UNIT: mm)

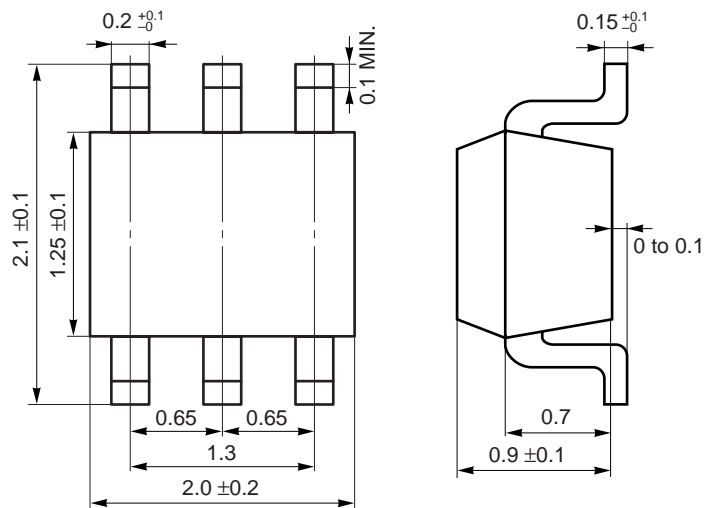

RECOMMENDED SOLDERING CONDITIONS

This product should be soldered under the following recommended conditions. For soldering method and conditions other than those recommended below, contact your NEC sales representative.

Soldering Method	Soldering Conditions	Recommended Condition Symbol
Infrared Reflow	Package peak temperature: 235 °C or below Time: 30 seconds or less (at 210 °C) Count: 3, Exposure limit: None ^{Note}	IR35-00-3
VPS	Package peak temperature: 215 °C or below Time: 40 seconds or less (at 200 °C) Count: 3, Exposure limit: None ^{Note}	VP15-00-3
Wave Soldering	Soldering bath temperature: 260 °C or below Time: 10 seconds or less Count: 1, Exposure limit: None ^{Note}	WS60-00-1
Partial Heating	Pin temperature: 300 °C Time: 3 seconds or less (per pin row) Exposure limit: None ^{Note}	—

Note After opening the dry pack, keep it in a place below 25 °C and 65 % RH for the allowable storage period.

Caution Do not use different soldering methods together (except for partial heating).

For details of recommended soldering conditions for surface mounting, refer to information document **SEMICONDUCTOR DEVICE MOUNTING TECHNOLOGY MANUAL (C10535E)**.

CAUTION

The Great Care must be taken in dealing with the devices in this guide.

The reason is that the material of the devices is GaAs (Gallium Arsenide), which is designated as harmful substance according to the law concerned.

Keep the law concerned and so on, especially in case of removal.

- **The information in this document is subject to change without notice. Before using this document, please confirm that this is the latest version.**
 - No part of this document may be copied or reproduced in any form or by any means without the prior written consent of NEC Corporation. NEC Corporation assumes no responsibility for any errors which may appear in this document.
 - NEC Corporation does not assume any liability for infringement of patents, copyrights or other intellectual property rights of third parties by or arising from use of a device described herein or any other liability arising from use of such device. No license, either express, implied or otherwise, is granted under any patents, copyrights or other intellectual property rights of NEC Corporation or others.
 - Descriptions of circuits, software, and other related information in this document are provided for illustrative purposes in semiconductor product operation and application examples. The incorporation of these circuits, software, and information in the design of the customer's equipment shall be done under the full responsibility of the customer. NEC Corporation assumes no responsibility for any losses incurred by the customer or third parties arising from the use of these circuits, software, and information.
 - While NEC Corporation has been making continuous effort to enhance the reliability of its semiconductor devices, the possibility of defects cannot be eliminated entirely. To minimize risks of damage or injury to persons or property arising from a defect in an NEC semiconductor device, customers must incorporate sufficient safety measures in its design, such as redundancy, fire-containment, and anti-failure features.
 - NEC devices are classified into the following three quality grades:
"Standard", "Special", and "Specific". The Specific quality grade applies only to devices developed based on a customer designated "quality assurance program" for a specific application. The recommended applications of a device depend on its quality grade, as indicated below. Customers must check the quality grade of each device before using it in a particular application.
 - Standard: Computers, office equipment, communications equipment, test and measurement equipment, audio and visual equipment, home electronic appliances, machine tools, personal electronic equipment and industrial robots
 - Special: Transportation equipment (automobiles, trains, ships, etc.), traffic control systems, anti-disaster systems, anti-crime systems, safety equipment and medical equipment (not specifically designed for life support)
 - Specific: Aircraft, aerospace equipment, submersible repeaters, nuclear reactor control systems, life support systems or medical equipment for life support, etc.
- The quality grade of NEC devices is "Standard" unless otherwise specified in NEC's Data Sheets or Data Books. If customers intend to use NEC devices for applications other than those specified for Standard quality grade, they should contact an NEC sales representative in advance.