

WHITE LED DRIVER

FEATURES

- Very High Speed Adjustable OSC (Max 800 kHz)
- Very Wide Operating Voltage Range (2.3 V to 10 V)
- Low Loss Detector (Low Reference Voltage: $V_{REF} = 0.5 V$)
- Operates with Toko D31FU Miniature Coil (Current Limited by Input Current Sensor)
- Internal Switching Transistor
- Internal Diode
- Active High On / Off Control
- Available Intensity Control Using EN Pin with PWM Signal
- Very Small SOT23L-8 Surface Mount Package

DESCRIPTION

The TK11850L is a pulse skipping step-up DC-DC converter IC designed for White LED driver applications with the following built in: a very high current switching transistor (400 mA peak), an inductor current limit detector, low voltage reference ($V_{ref} = 0.5 V$), high speed oscillator, an error comparator, a rectifier diode (for small power output) and an ON/OFF control. The IC works with a very wide operating supply range (2.3 V to 10 V) and the adjustable output voltage can be set as high as 20 V. The device is in the ON state when the EN pin is pulled to a high level. Using the very small TK11850L and a few external components, battery powered systems with LCD displays such as digital cameras and cellular phones can be effectively backlit with white LEDs. The white LEDs are connected in series and driven at a constant current resulting in uniform brightness and high efficiency. This IC has an oscillator, which allows the designer to set the operating frequency by an external capacitor with the output controlled by pulse skipping. The reference voltage is a very low 0.5 V, achieving high efficiency operation with the constant current output. A small coil can be used because the inductor current limit detector circuit limits the peak current (caused by an input

APPLICATIONS

- LED Backlighting and Frontlighting
- LED Flashlights
- Step-up DC-DC Converters

voltage increase or the inrush current as start-up) that flows through the coil. The ON /OFF control is built-in and the circuit current can be decreased when the EN pin is low (standby mode). The white LEDs can be dimmed by applying a PWM signal to the EN (ON/OFF control) pin. With this method, the white LED brightness is still controlled by constant current resulting in constant chromaticity.

The TK11850L is available in the SOT23L-8 surface mount package.

ORDERING INFORMATION

TK11850L

Tape/Reel Code

TAPE/REEL CODE
TL: Tape Left

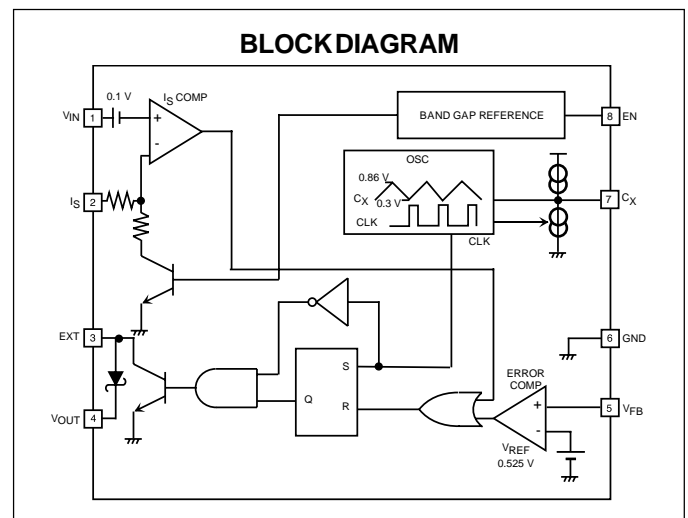
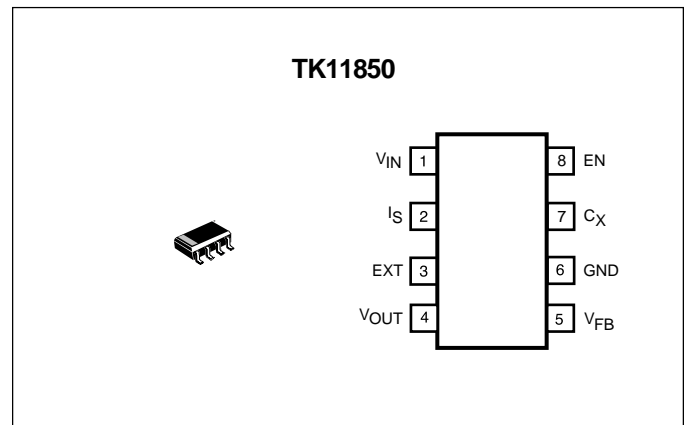

TK11850L

ABSOLUTE MAXIMUM RATINGS

Supply Voltage	20 V	Operating Temperature Range	-30 to +85 °C
Switching Voltage	20 V	Switching Peak Current	400 mA
Operating Voltage Range	2.3 to 10 V	Diode Current	10 mA
Power Dissipation (Note 1)	400 mW	Maximum Frequency	~ 800 kHz
Storage Temperature Range	-55 to +150 °C		

TK11850 ELECTRICAL CHARACTERISTICS

Test Conditions: $V_{IN} = 3\text{ V}$, $V_{IS} = V_{EN} = V_{IN}$, $V_{EXT} = \text{Open}$, $V_{FB} = \text{GND}$, $C_X = 100\text{ pF}$, $T_A = 25\text{ °C}$, unless otherwise specified.

SYMBOL	PARAMETER	TEST CONDITIONS	MIN	TYP	MAX	UNITS
OSCILLATOR SECTION (C_X PIN)						
I_{CHG}	C_X Charging Current	$V_{CX} = 0.1\text{ V}$	16	22	30	μA
I_{DIS}	C_X Discharging Current	$V_{CX} = 1.0\text{ V}$	35	49	65	μA
I_{DIS} / I_{CHG}	Charge and Discharge Current Ratio			2.2		
$V_{CX(HIGH)}$	C_X Threshold Voltage +	V_{CX} at $I_{CHG} = 0\mu\text{A}$	810	860	910	mV
$V_{CX(LOW)}$	C_X Threshold Voltage -	V_{CX} at $I_{DIS} = 0\mu\text{A}$	260	300	340	mV
V_{OSC}	C_X Oscillation Voltage	$(V_{th+}) - (V_{th-})$	520	560	600	mV
CURRENT LIMITING COMPARATOR SECTION (I_S PIN)						
V_{LIMIT}	Current Limit Sense Voltage	$V_{LIMIT} = V_{IN} - V_{IS}$	72	77	82	mV
I_{ISIn}	I_S Pin Bias Current	$V_{IN} = V_{IS} = 3\text{ V}$	5	10	15	μA
OUTPUT SWITCH SECTION (EXT PIN)						
$V_{SW, Sat}$	Output Transistor Saturation Voltage	$V_{CX} = 0\text{ V}$, $I_{SW} = 200\text{ mA}$		0.2	0.4	V
$I_{SW, Off}$	Output Transistor Off Leakage Current	$V_{FB} = 1\text{ V}$, $V_{EXT} = 20\text{ V}$		0.01	2	μA
FEEDBACK COMPARATOR SECTION (V_{FB} PIN)						
V_{REF}	Reference Voltage		0.505	0.525	0.545	V
I_{FBIn}	V_{FB} Pin Output Current	$V_{FB} = 0.4\text{ V}$	-2	-0.3		μA

Note 1: Power dissipation is 400 mW when mounted. Derate at 3.2 mW / °C for operation above 25 °C.

TK11850 ELECTRICAL CHARACTERISTICS (CONT)

Test Conditions: $V_{IN} = 3\text{ V}$, $V_{IS} = V_{EN} = V_{IN}$, $V_{EXT} = \text{Open}$, $V_{FB} = \text{GND}$, $C_X = 100\text{ pF}$, $T_A = 25\text{ }^\circ\text{C}$, unless otherwise specified.

SYMBOL	PARAMETER	TEST CONDITIONS	MIN	TYP	MAX	UNITS
SHUTDOWN SECTION (EN PIN)						
$V_{EN(HIGH)}$	EN Threshold Voltage +	On Mode			2	V
$V_{EN(LOW)}$	EN Threshold Voltage -	Shutdown Mode	0.6			V
I_{ENIN}	EN Pin Bias Current	$V_{IN} = V_{EN} = 3\text{ V}$	2	5	8	μA
DIODE SECTION (EXT PIN - V_{OUT} PIN)						
V_F	Forward Voltage	$I_D = 10\text{ mA}$		0.75		V
V_{IN} SECTION (V_{IN} PIN)						
$V_{IN(LOW)}$	Low Voltage Stop		1.7	2.0	2.3	V
$V_{IN(HIGH)}$	High Voltage Output Stop		11	12.5	14	V
$I_{CC(Off)}$	Shutdown Supply Current	$V_{EN} = 0\text{ v}$		0.01	1	μA
$I_{CC(On)}$	Quiescent Supply Current	$V_{FB} = 1\text{ V}$	1	1.5	2	mA
Reference Value						
η	Efficiency	$I_{LOAD} = 20\text{ mA}$, $V_{OUT} = 16.5\text{ V}$, $V_{IN} = 3.6\text{ V}$ (Note 2)		78		%

Note 2: This value is different depending on the components used, circuit conditions, etc. Thus, this is reference data only. Refer to Reference data test circuit.

TEST CIRCUIT

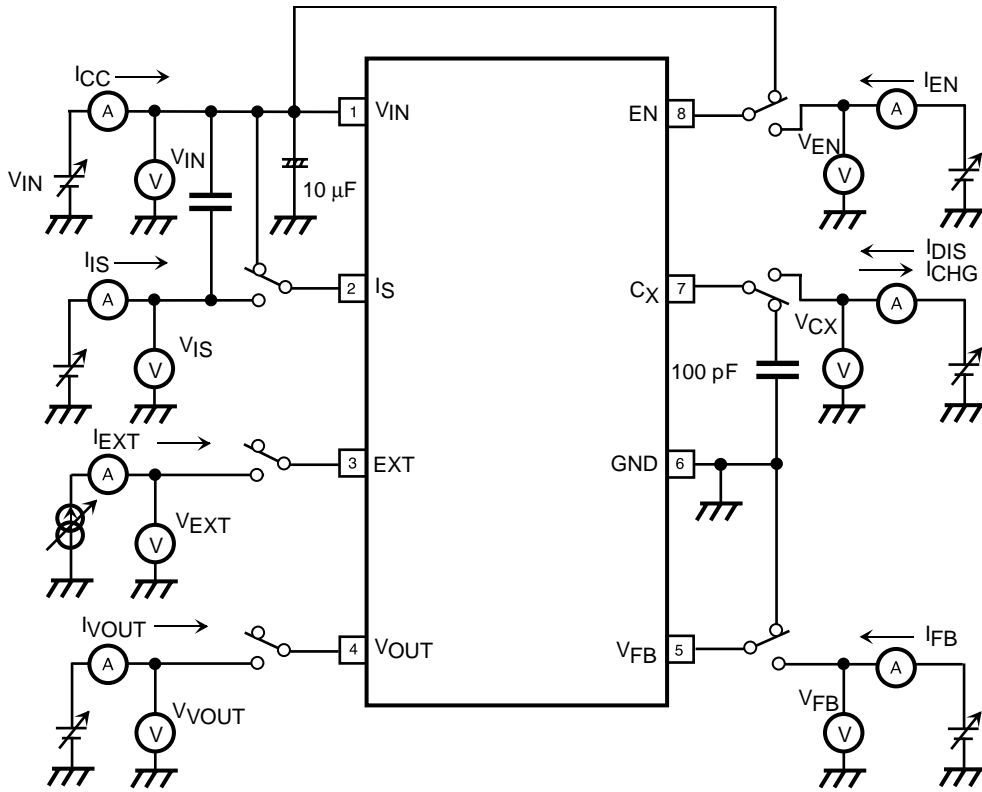

REFERENCE DATA TEST CIRCUIT

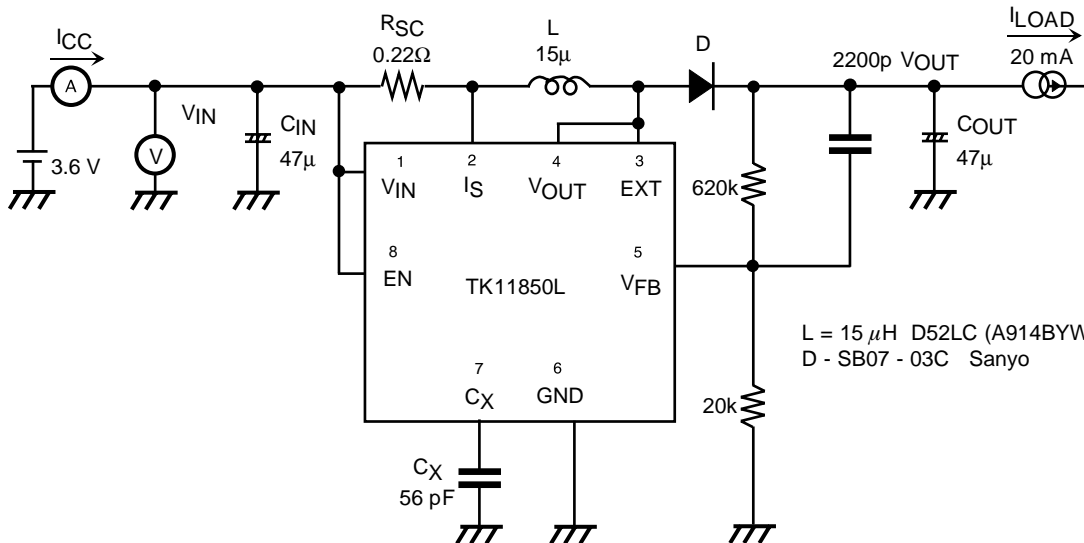

TYPICAL PERFORMANCE CHARACTERISTICS

$T_A = 25\text{ }^\circ\text{C}$, unless otherwise specified.

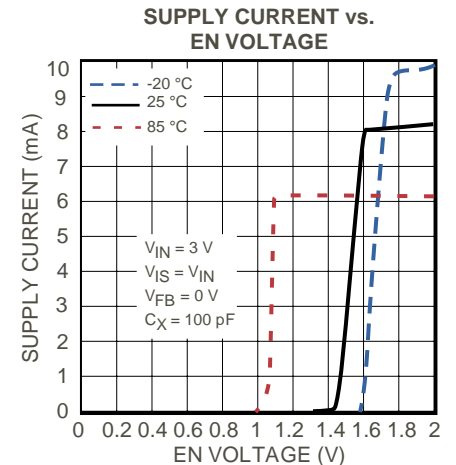
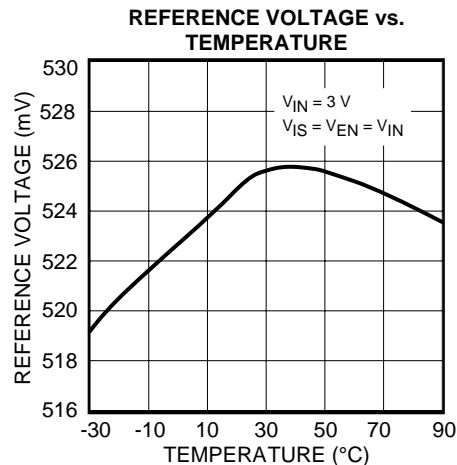
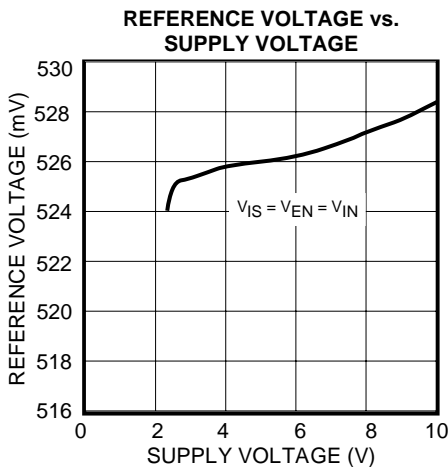
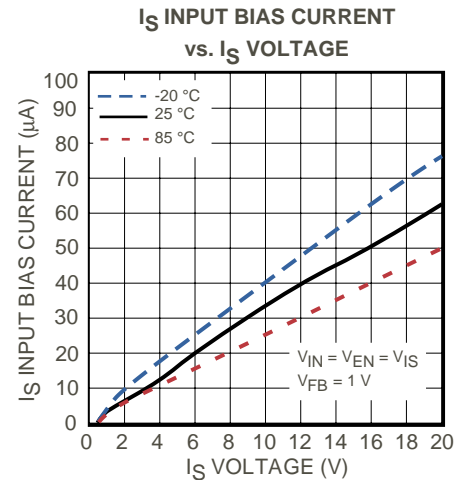
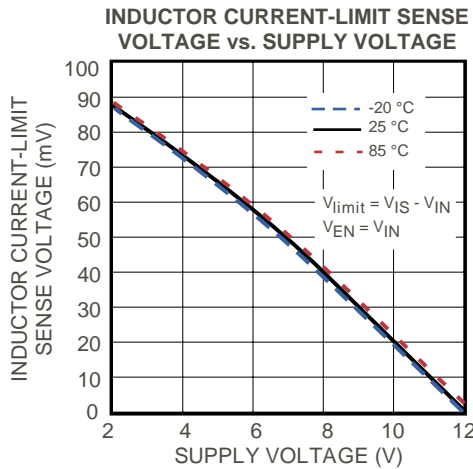
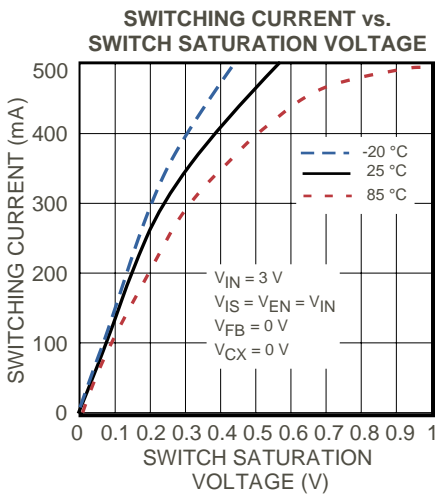
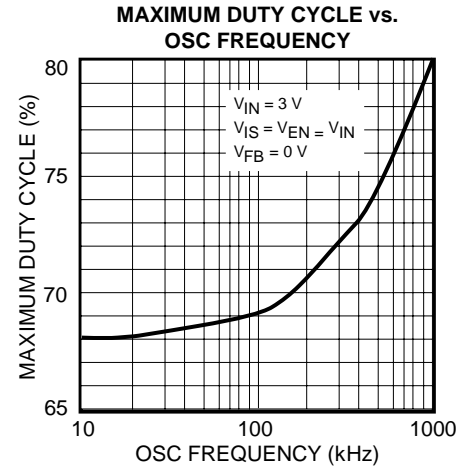
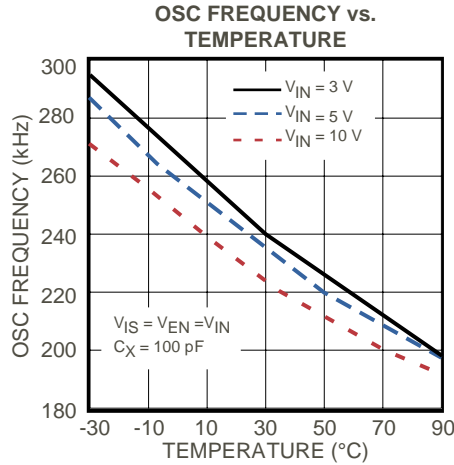
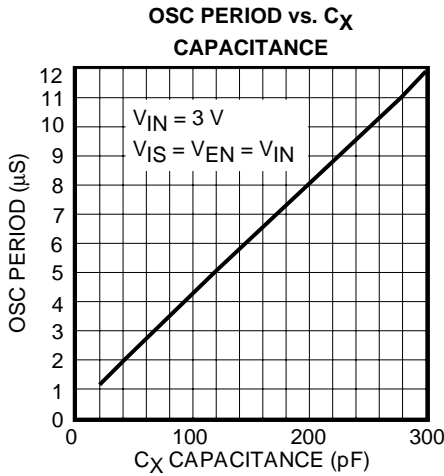

TYPICAL PERFORMANCE CHARACTERISTICS (CONT.)

$T_A = 25\text{ }^\circ\text{C}$, unless otherwise specified.

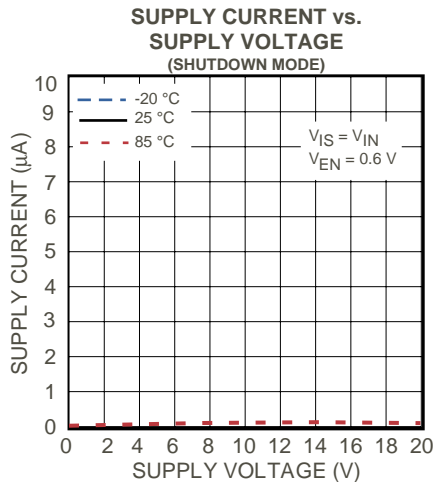
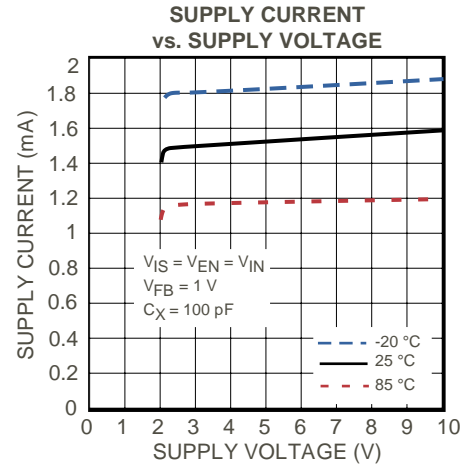
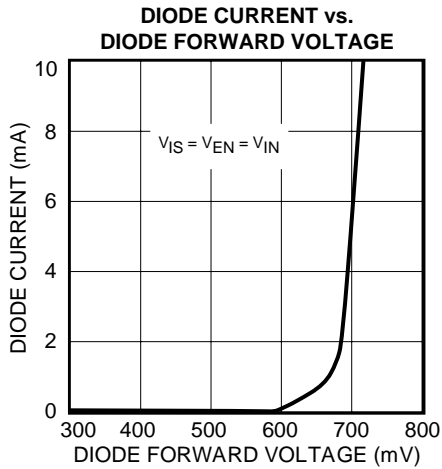
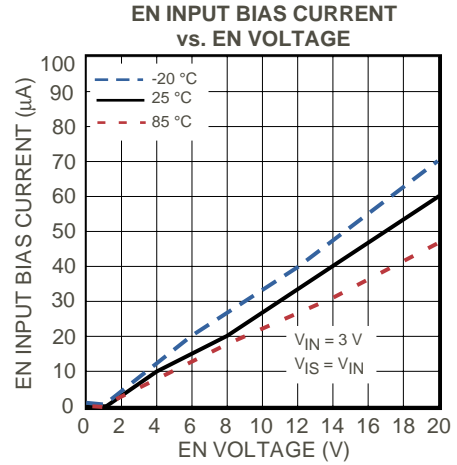
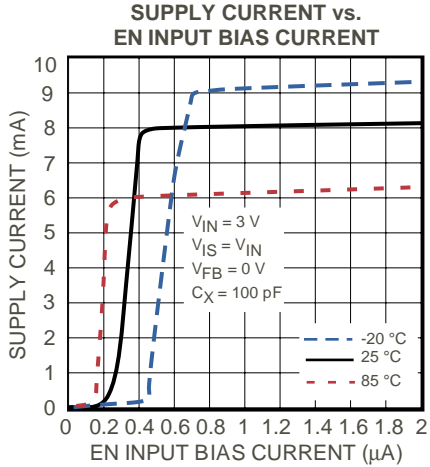

APPLICATION CIRCUIT (2 LEDs in Series)

- Input Voltage: 2.7 V
- LED Current : 20 mA
- On/Off: Pin Number 8 (EN Pin)
LED Current (I_{LED}) is set by R_{LED} .
 I_{LED} doesn't depend on V_{IN} because I_{LED} is controlled by the feedback circuit.

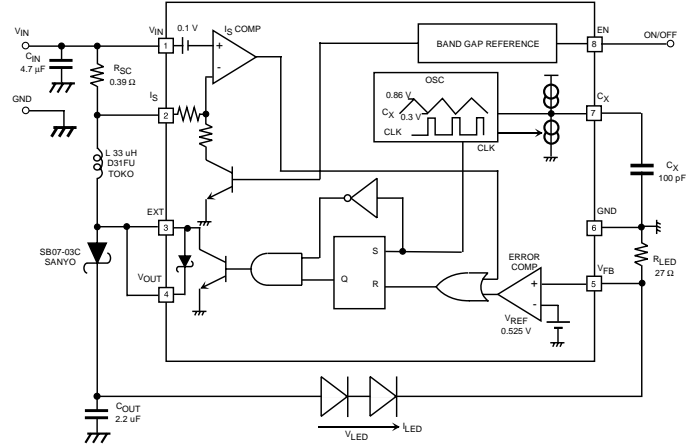

TYPICAL PERFORMANCE CHARACTERISTICS

$T_A = 25\text{ }^\circ\text{C}$, unless otherwise specified.

LED Current and Efficiency Characteristics

V_{IN} (V)	I_{IN} (mA)	V_{LED} (V)	I_{LED} (mA)	EF LED (%)
2.7	71.3	7.01	18.81	68.6
3.0	62.9	7.01	18.85	70.0
3.5	52.8	7.02	18.95	71.9
4.5	39.9	7.02	19.10	74.8

L: D31FU, 33 μ H
Toko Part Number: 888FU-330M

$$EF\ LED\ (\%) = 100 * V_{LED} * I_{LED} / V_{IN} * I_{IN}$$

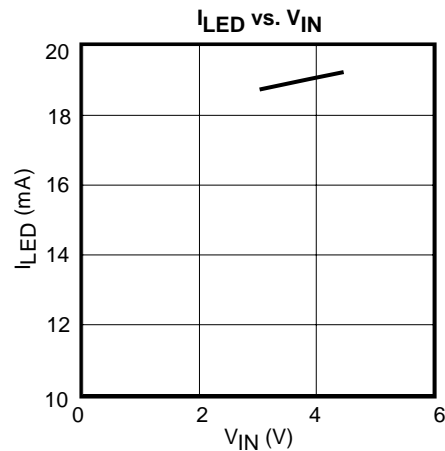
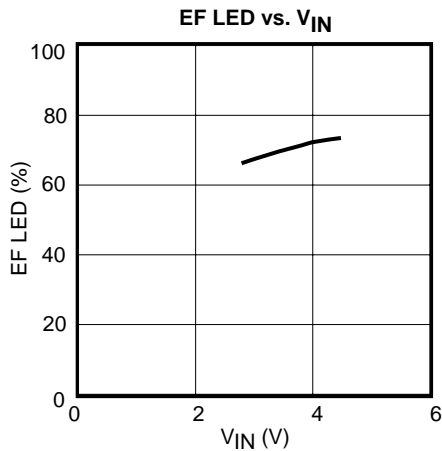

APPLICATION CIRCUIT (3 LEDs in Series)

- **Input Voltage: 2.7 V**
 - **LED Current: 20 mA**
 - **On/Off: Pin Number 8 (EN Pin)**
- LED Current (I_{LED}) is set by R_{LED} .
 I_{LED} doesn't depend on V_{IN} because I_{LED} is controlled by the feedback circuit.

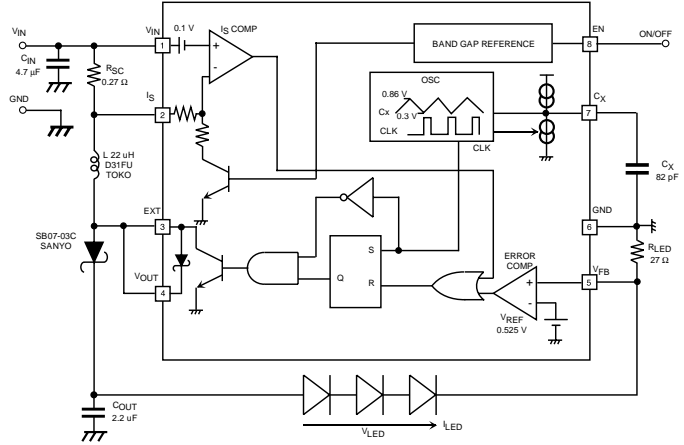

TYPICAL PERFORMANCE CHARACTERISTICS (CONT.)

$T_A = 25\text{ }^\circ\text{C}$, unless otherwise specified.

LED Current and Efficiency Characteristics

V_{IN} (V)	I_{IN} (mA)	V_{LED} (V)	I_{LED} (mA)	EF LED (%)
2.5	115.9	10.38	19.41	69.52
2.7	106.9	10.38	19.49	70.09
3.0	95.4	10.38	19.52	70.83
3.5	79.1	10.38	19.52	73.19
4.5	59.2	10.39	19.56	76.26
6.0	42.9	10.39	19.60	79.04

L: D31FU, 22 μ H
 Toko Part Number: 888FU-220M

$$EF\ LED\ (\%) = 100 * V_{LED} * I_{LED} / V_{IN} * I_{IN}$$

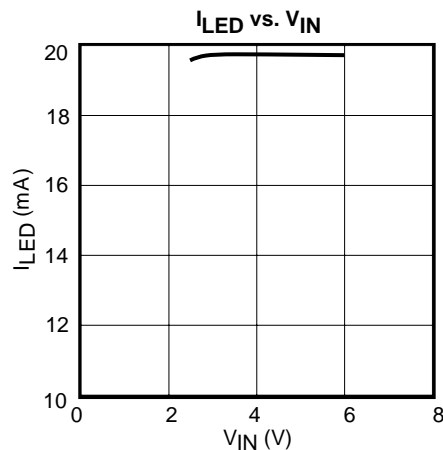
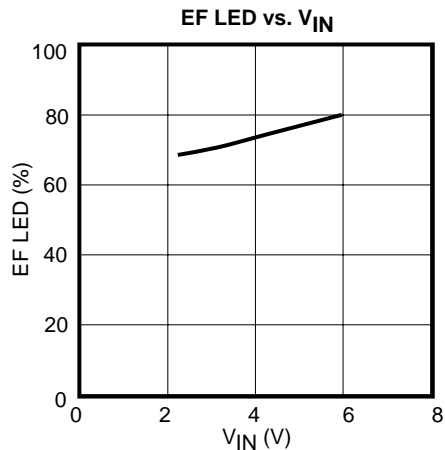

APPLICATION CIRCUIT (4 LEDs in Series)

- **Input Voltage: 2.7 V**
 - **LED Current: 20 mA**
 - **On/Off: Pin Number 8 (EN Pin)**
- LED Current (I_{LED}) is set by R_{LED} .
 I_{LED} doesn't depend on V_{IN} because I_{LED} is controlled by the feedback circuit.

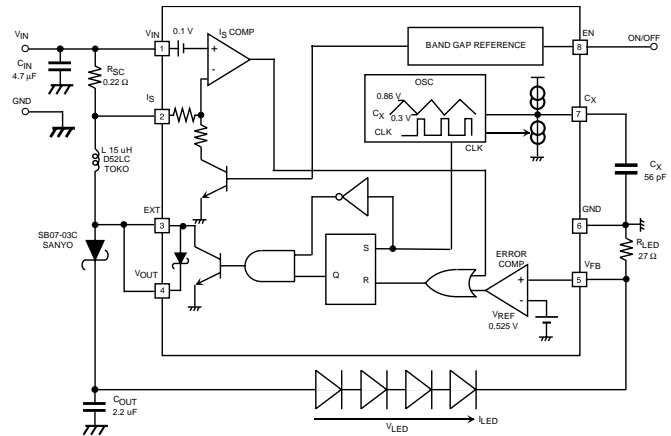

TYPICAL PERFORMANCE CHARACTERISTICS (CONT.)

$T_A = 25\text{ }^\circ\text{C}$, unless otherwise specified.

LED Current and Efficiency Characteristics

V_{IN} (V)	I_{IN} (mA)	V_{LED} (V)	I_{LED} (mA)	EF LED (%)
2.5	144.4	13.68	19.32	73.30
2.7	132.2	13.68	19.30	73.97
3.0	117.9	13.68	19.27	74.44
3.5	99.0	13.68	19.28	76.07
4.5	75.3	13.68	19.35	78.06
6.0	55.3	13.68	19.34	79.71

L: D52LC, 15 μ H
 Toko Part Number: A914BYNW - 150M

$$EF\ LED\ (\%) = 100 * V_{LED} * I_{LED} / V_{IN} * I_{IN}$$

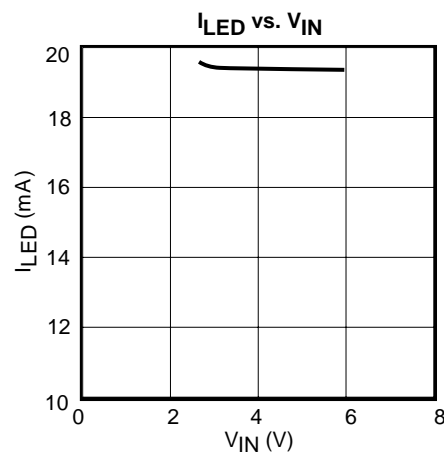
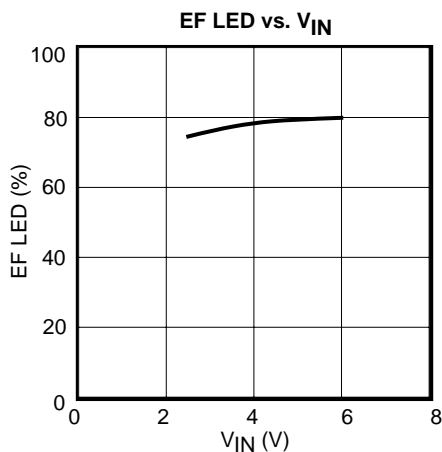

DIMMING

The following are 3 kinds of dimming methods.

1. Dimming by R_{LED}

The current of the LED (I_{LED}) is determined by R_{LED} , which can be set by switches such as transistors.

Example of 3 LEDs with a 4 brightness level circuit:

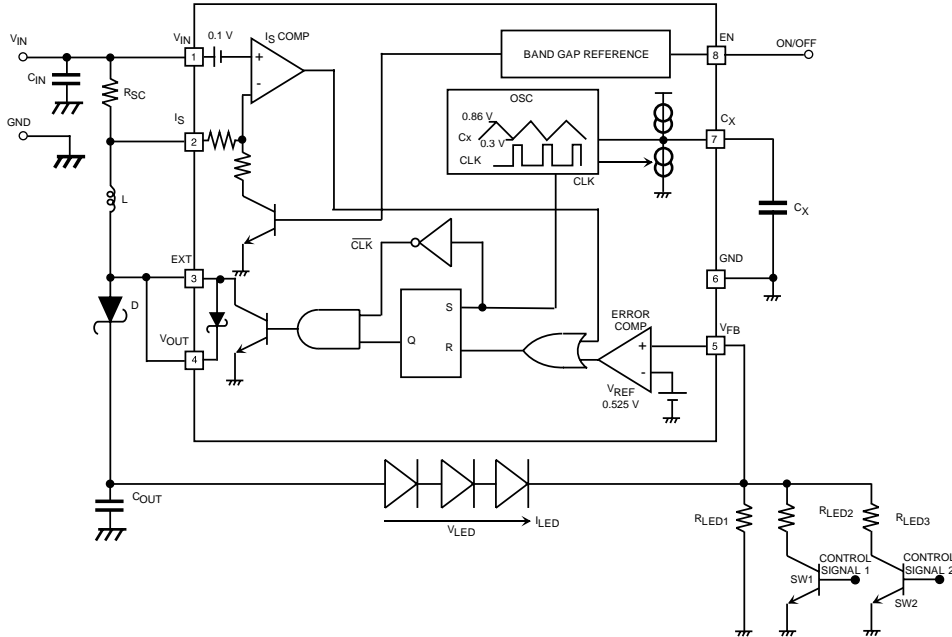

$$I_{LED} = \frac{V_{REF}}{R_{LED}}$$

R_{LED} : Total value of Resistors

$V_{REF} = 0.525 \text{ V (typ)}$

V_{FB} Voltage = 0.525 V (typ)

I_{LED} vs. R_{LED}

$R_{LED} (\Omega)$	$I_{LED} (\text{mA})$
24	21.9
27	19.5
36	14.6
51	10.4
100	5.4
510	1.1

LED CURRENT (I_{LED}) vs. TOTAL RESISTANCE (R_{LED})

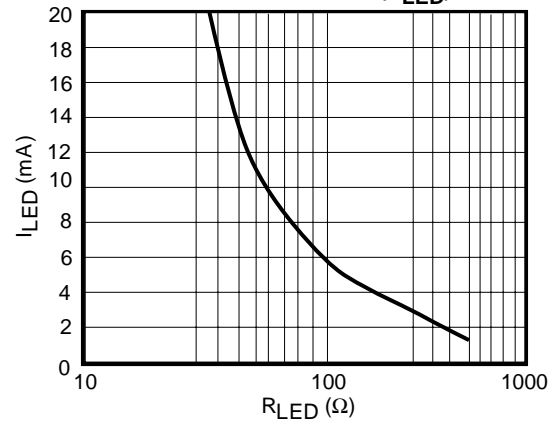

DIMMING (CONT)

2. PWM Dimming

Apply the PWM signal to the EN Terminal (Pin no. 8). In this case, a signal frequency of approximately 120 Hz is adequate. The average current of the LED changes due to the On/Off cycle of the IC, which follows the duty cycle of the PWM signal.

Set the PWM signal at a high level over 2 V and a low level under 0.6 V, with a driving current over 2 μ A.

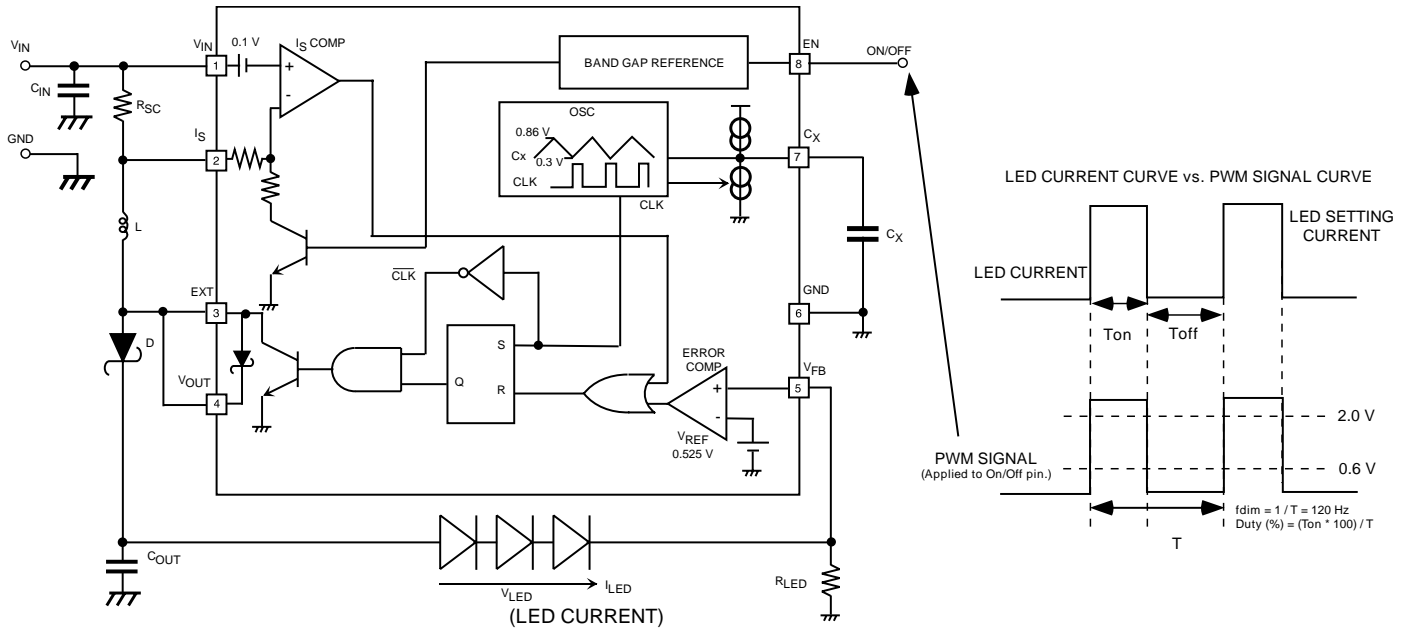

The PWM dimming LED current follows the PWM signal. (As shown above)

The average LED current is obtained from the formula below. The graph below shows an example with $I_{LED(MAX)}$ (20 mA) at a Duty Cycle up to 100%.

I_{LED} vs. DUTY

$$I_{LED(AVG)} = I_{LED(MAX)} * \frac{Duty}{100}$$

DUTY (%)	I_{LED} (mA)
100	20.0
90	18.0
80	16.0
70	14.0
60	12.0
50	10.0
40	8.0
30	6.0
20	4.0
10	2.0

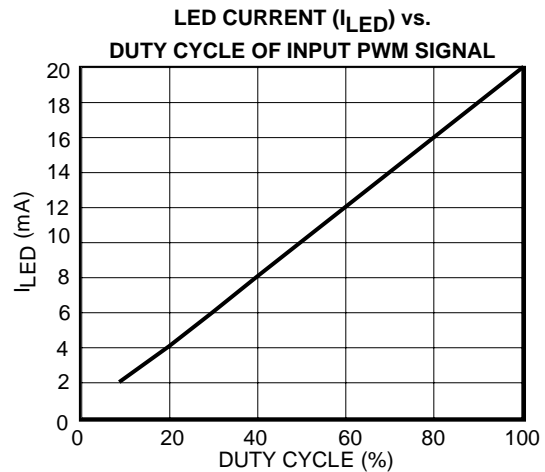

TK11850L

Input PWM signal curve vs. LED current curve (ex. Three LEDs, Output current 20 mA)

(1) Duty Cycle = 80%

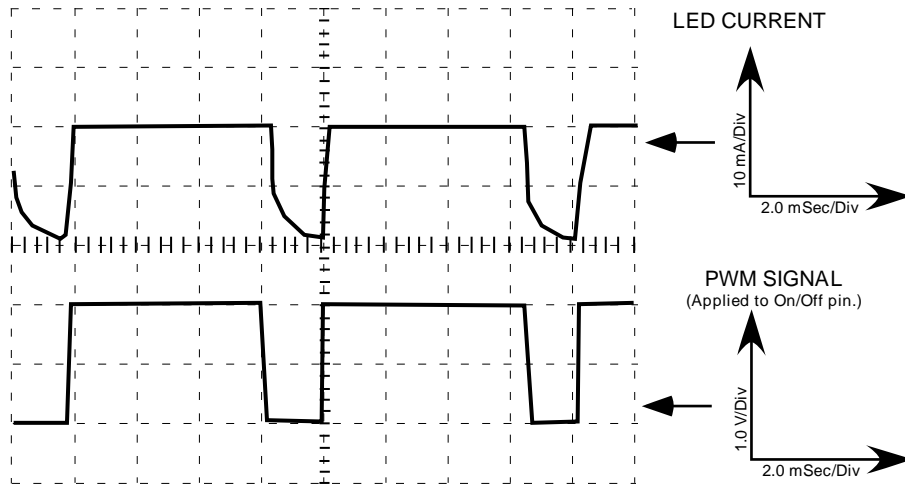

(2) Duty Cycle = 50%

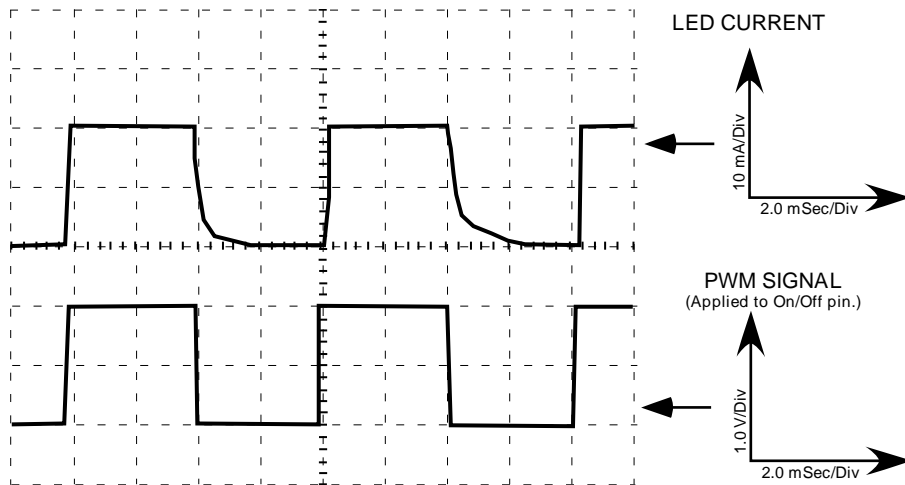

(3) Duty Cycle = 20%

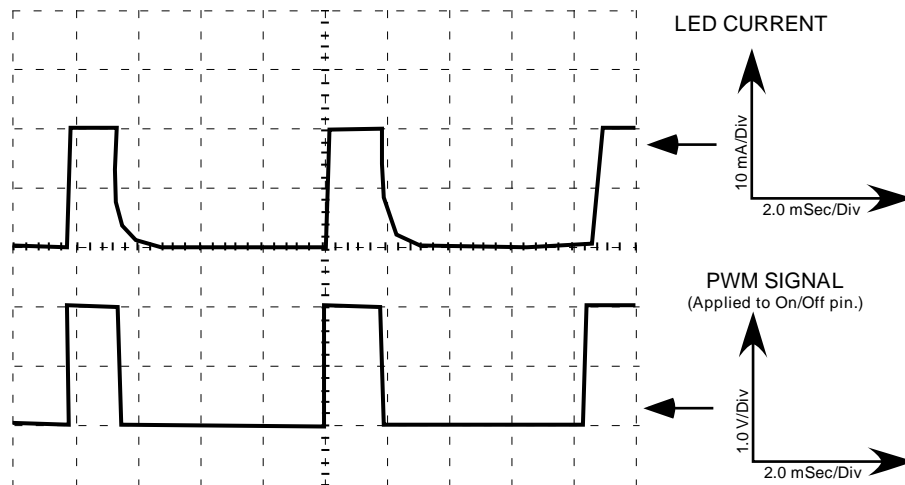

DIMMING (CONT)

3. Dimming by DAC (D/A Converter) output

Dimming is achievable by applying a DAC output to the V_{FB} terminal with the addition of R_{DAC1} and R_{DAC2} .

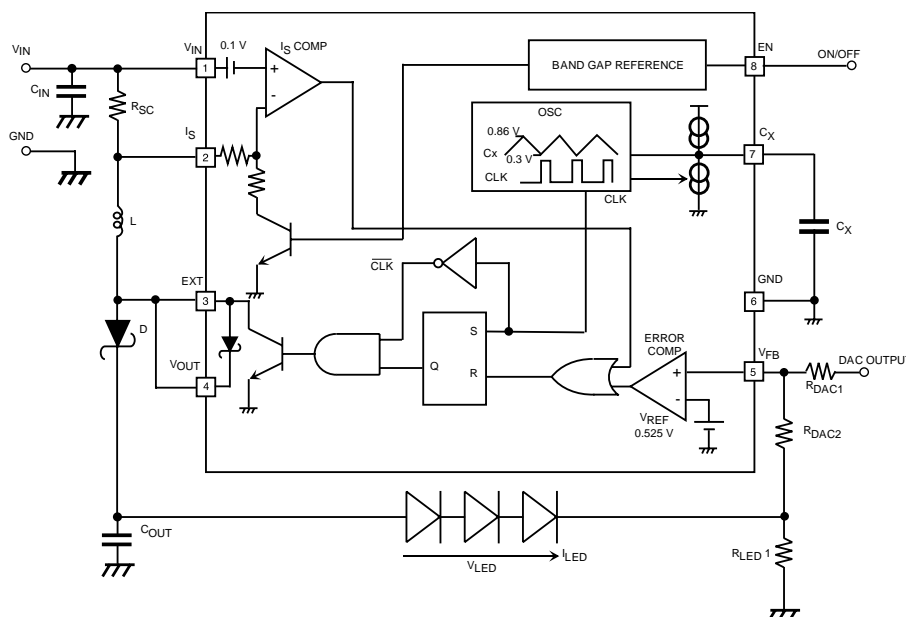

Example Conditions:

$$R_{DAC1} = R_{DAC2}$$

$$R_{LED} = 49 \Omega$$

I_{LED} vs. V_{DAC}

DAC VOLTAGE (V)	LED CURRENT (mA)
0.1	19.58
0.2	17.45
0.3	15.32
0.4	13.21
0.5	11.08
0.6	8.95
0.7	6.84
0.8	4.71
0.9	2.6
1	0.5

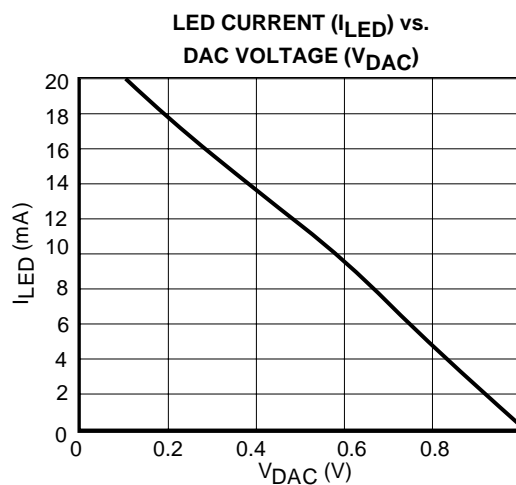

PACKAGE OUTLINE

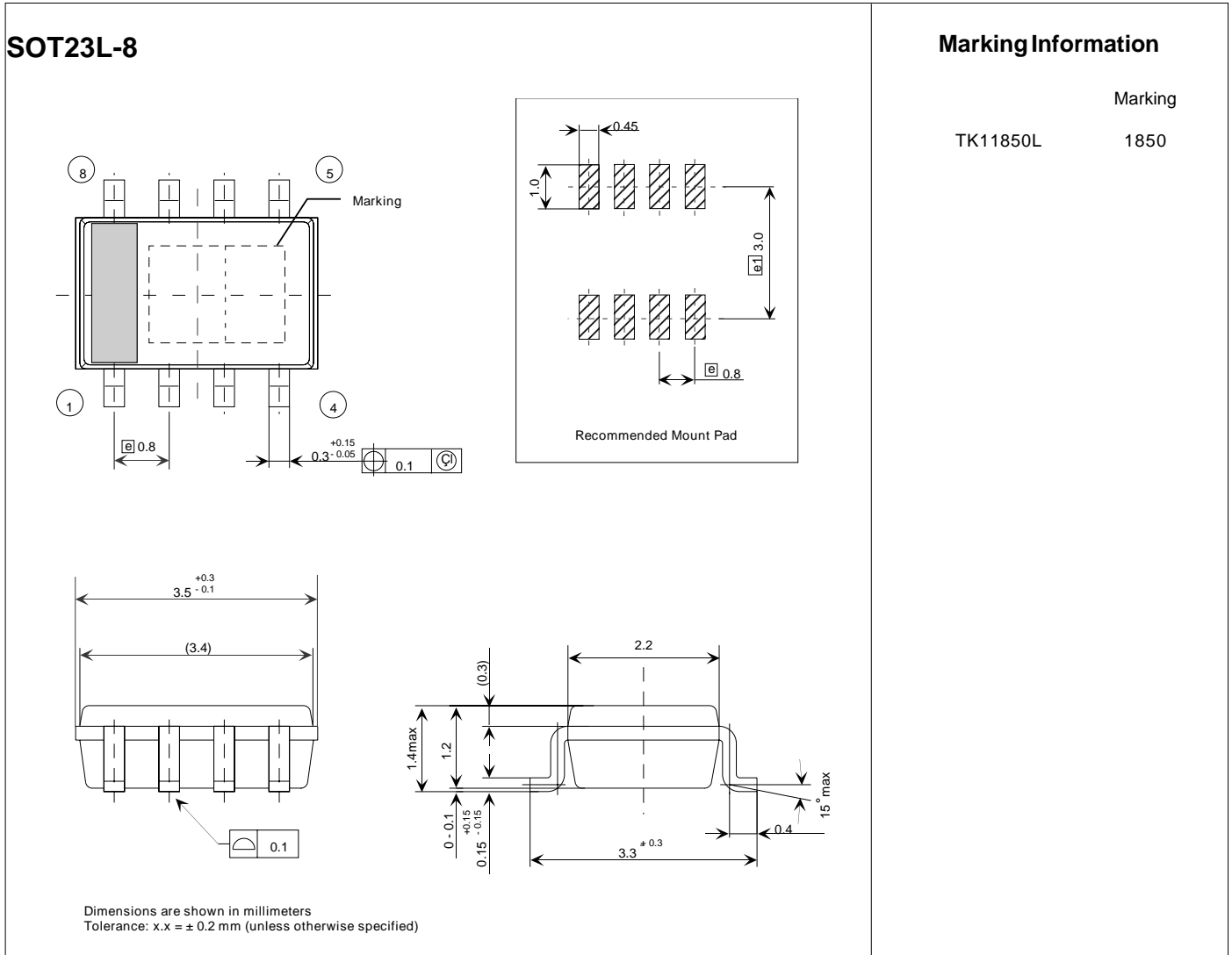

Toko America, Inc. Headquarters
 1250 Feehanville Drive, Mount Prospect, Illinois 60056
 Tel: (847) 297-0070 Fax: (847) 699-7864

TOKOAMERICAREGIONALOFFICES

Midwest Regional Office
 Toko America, Inc.
 1250 Feehanville Drive
 Mount Prospect, IL 60056
 Tel: (847) 297-0070
 Fax: (847) 699-7864

Western Regional Office
 Toko America, Inc.
 2480 North First Street, Suite 260
 San Jose, CA 95131
 Tel: (408) 432-8281
 Fax: (408) 943-9790

Semiconductor Technical Support
 Toko Design Center
 4755 Forge Road
 Colorado Springs, CO 80907
 Tel: (719) 528-2200
 Fax: (719) 528-2375

Visit our Internet site at <http://www.tokoam.com>

The information furnished by TOKO, Inc. is believed to be accurate and reliable. However, TOKO reserves the right to make changes or improvements in the design, specification or manufacture of its products without further notice. TOKO does not assume any liability arising from the application or use of any product or circuit described herein, nor for any infringements of patents or other rights of third parties which may result from the use of its products. No license is granted by implication or otherwise under any patent or patent rights of TOKO, Inc.