

# APPLICATION MANUAL



**WHITE LED DRIVER**  
**Step-up DC-DC Converter IC**  
**TK11851L**

**CONTENTS**

|                                 |    |
|---------------------------------|----|
| 1 . DESCRIPTION                 | 2  |
| 2 . FEATURES                    | 2  |
| 3 . APPLICATIONS                | 2  |
| 4. TYPICAL APPLICATION          | 2  |
| 5. PIN CONFIGURATION            | 3  |
| 6. BLOCK DIAGRAM                | 3  |
| 7. STANDARD APPLICATION CIRCUIT | 4  |
| 8. ABSOLUTE MAXIMUM RATINGS     | 5  |
| 9. ELECTRICAL CHARACTERISTICS   | 6  |
| 10. TEST CIRCUIT                | 7  |
| 11. TYPICAL CHARACTERISTICS     | 8  |
| 12. PIN DESCRIPTION             | 11 |
| 13. CIRCUIT DESCRIPTION         | 12 |
| 14. WHITE LED APPLICATION       | 20 |
| 15. PACKAGE OUTLINE             | 23 |
| 16. NOTES                       | 24 |
| 17. OFFICES                     | 24 |



# WHITE LED DRIVER Step-up DC-DC Converter IC TK11851L

## 1. DESCRIPTION

The TK11851L is a pulse skipping step-up DC-DC converter IC designed for White LED driver applications with the following built in: a very high current switching transistor (400 mA peak), an inductor current limit detector, a low voltage reference ( $V_{ref} = 0.515\text{ V}$ ), a high speed oscillator, an error comparator, a zener diode for open-circuit protection and an ON/OFF control. The IC works with a very wide operating supply range (2.3 V to 10 V) and the adjustable output voltage can be set as high as 20 V. The device is in the ON state when the En pin is pulled to a high level. Using the very small TK11851L and a few external components, battery powered systems with LCD displays, such as digital cameras and cellular phones, can be effectively backlit with white LEDs. The white LEDs are connected in series and driven at a constant current, resulting in uniform brightness and high efficiency. This IC has an adjustable oscillator, which allows the designer to set the operating frequency by an external capacitor with the output controlled by pulse skipping. The reference voltage is a very low 0.515 V, achieving high efficiency operation with the constant current output. A small coil can be used because the inductor current limit detector circuit limits the peak current (caused by an input voltage increase or the inrush current at start-up) that flows through the coil. The ON /OFF control is built-in and the circuit current can be decreased when the En pin is low (shutdown mode). The white LEDs can be dimmed by applying a PWM signal to the En (ON / OFF control) pin. With this method, the white LED brightness is still controlled by constant current, resulting in constant chromaticity.

The built-in zener diode can be used for open-circuit protection in case the output load is disconnected, such as the string of LEDs opened. The internal zener diode reduces the external component count.

The TK11851L can also be used in other applications as a step-up DC-DC converter.

The TK11851L is available in the SOT23L-8 surface mount package.

## 2. FEATURES

- Very High Speed Adjustable OSC (800kHz Max)
- Very Wide Operating Voltage Range (2.3 V to 10 V)
- Low Loss Detector (Low Reference Voltage:  $V_{ref} = 0.515\text{ V}$ )
- Internal Switching Transistor
- Open-Circuit Protection (OVP)
- Active High On / Off Control
- Available Intensity Control Using En Pin with PWM Signal
- Low component Count
- Very Small SOT23L-8 Surface Mount Package

## 3. APPLICATIONS

- LED Backlighting and Frontlighting
- LED Flashlights
- Step-up DC-DC Converters

## 4. TYPICAL APPLICATION

### APPLICATION CIRCUIT (3 LEDs in Series)

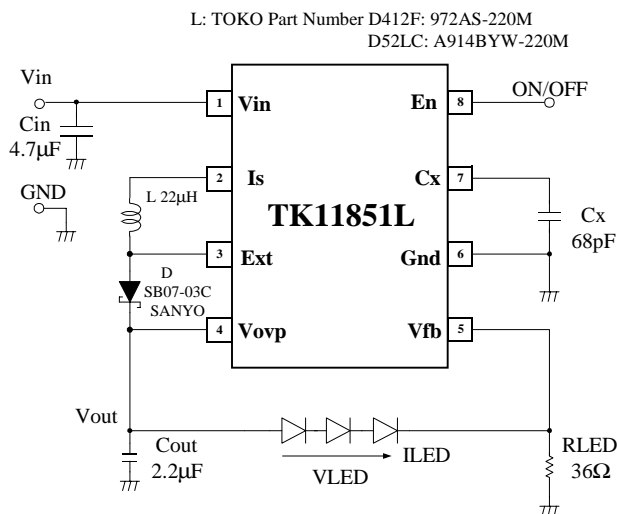

Efficiency vs. Supply Voltage

$$\text{Efficiency (\%)} = 100 \cdot V_{out} \cdot I_{LED} / (V_{in} \cdot I_{in})$$

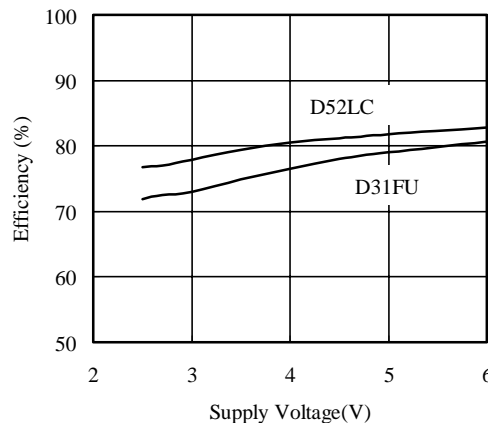

**5. PIN CONFIGURATION**

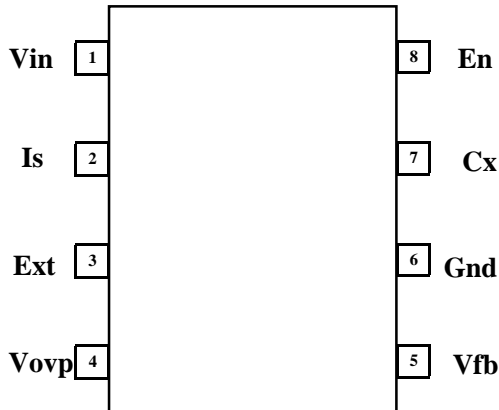

| Pin No. | SYMBOL | Function                    |
|---------|--------|-----------------------------|
| 1       | Vin    | Power Supply Voltage Input. |
| 2       | Is     | Inductor current limit.     |
| 3       | Ext    | External Inductor.          |
| 4       | Vovp   | Open-Circuit Protection     |
| 5       | Vfb    | Feedback Voltage.           |
| 6       | Gnd    | Ground.                     |
| 7       | Cx     | Timing Capacitor.           |
| 8       | En     | Enable (ON/OFF) Input.      |

**6. BLOCK DIAGRAM**

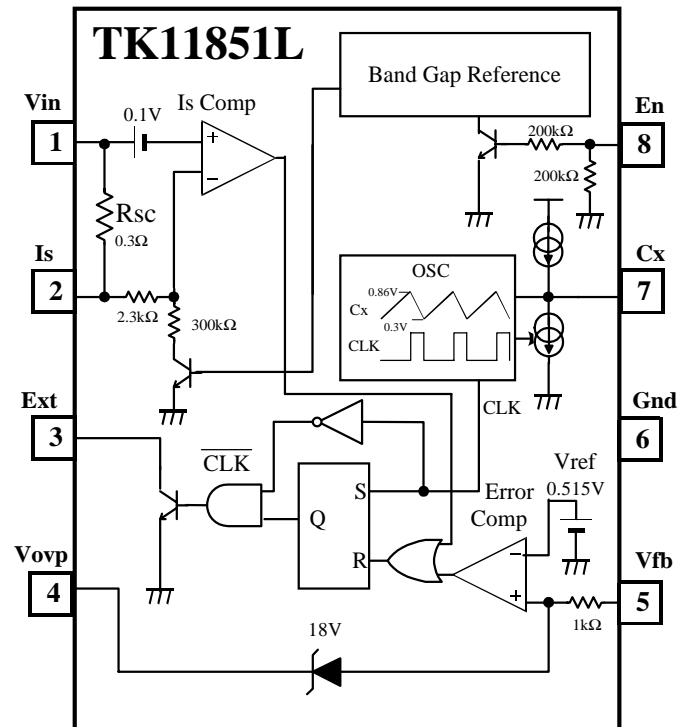

**7. STANDARD APPLICATION CIRCUIT**

**Standard Application circuit for white LED**

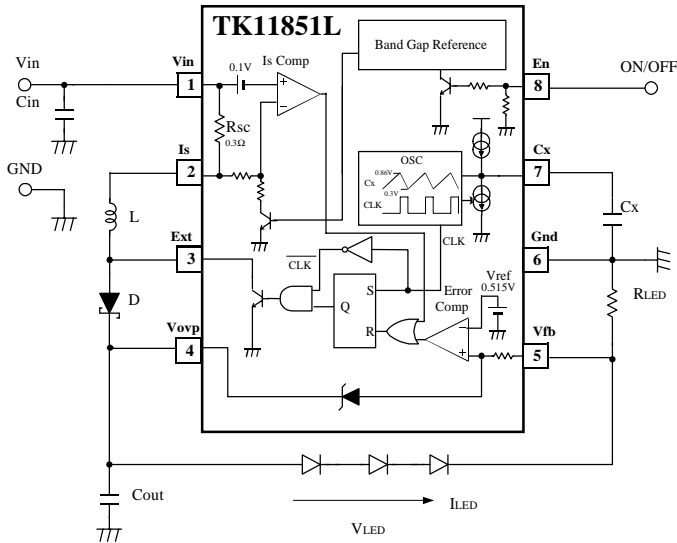

Cin: Input Capacitor  
 Cout: Output Capacitor  
 L: Inductor  
 D: Schottky Diode  
 R<sub>LED</sub>: LED Current Setting Resistor  
 C<sub>X</sub>: OSC Frequency Setting Capacitor

**Standard application circuit for LCD Bias**

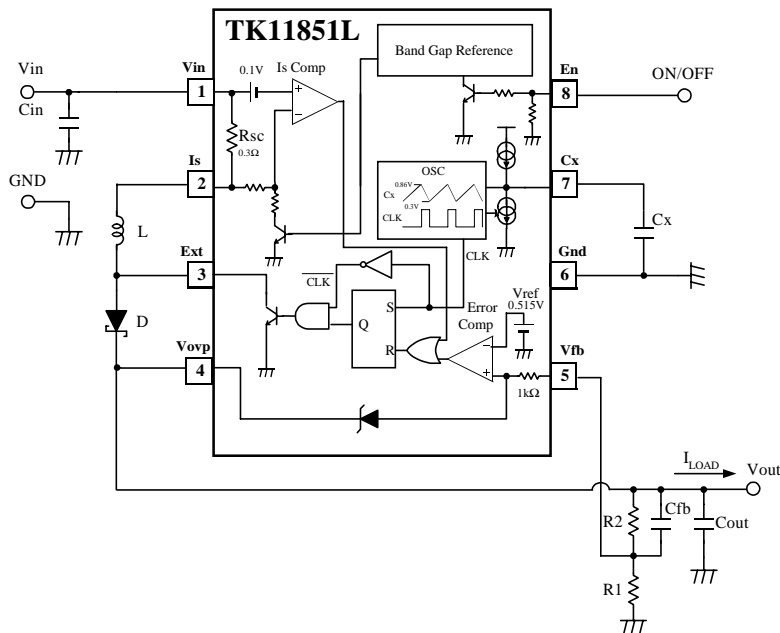

Cin: Input Capacitor  
 Cout: Output Capacitor  
 L: Inductor  
 D: Schottky Diode  
 R1, R2: Output Voltage Setting Resistor  
 Cfb: Compensation Capacitor  
 C<sub>X</sub>: OSC Frequency Setting Capacitor

**8. ABSOLUTE MAXIMUM RATINGS**

$T_a=25^{\circ}\text{C}$

| PARAMETER                   | SYMBOL         | RATINGS          | UNITS              | TEST CONDITIONS |
|-----------------------------|----------------|------------------|--------------------|-----------------|
| Supply Voltage              | $V_{in}$       | 20               | V                  |                 |
| Switch Voltage              | $V_{sw}$       | 20               | V                  |                 |
| Vovp Pin Voltage            | $V_{ovp}$      | -0.3 ~ $V_{OVP}$ | V                  |                 |
| Vfb Pin Voltage             | $V_{fb}$       | -0.3 ~ $V_{in}$  | V                  |                 |
| En Pin Voltage              | $V_{En}$       | -0.3 ~ 20        | V                  |                 |
| Switch Peak Current         | $I_{sw, peak}$ | 400              | mA                 |                 |
| Power Dissipation           | $P_D$          | 400              | mW                 | *               |
| Storage Temperature Range   | $T_{stg}$      | -55 ~ +150       | $^{\circ}\text{C}$ |                 |
| Operating Temperature Range | $T_{OP}$       | -30 ~ +85        | $^{\circ}\text{C}$ |                 |
| Maximum Frequency           | $f_{MAX}$      | ~800             | kHz                |                 |
| Operating Voltage Range     | $V_{OP}$       | 2.3 ~ 10         | V                  |                 |

$P_D$  must be decreased at the rate of  $3.2\text{mW}/^{\circ}\text{C}$  for operation above  $25^{\circ}\text{C}$ .

**9. ELECTRICAL CHARACTERISTICS**

$V_{in}=3V$ ,  $I_s=Open$ ,  $Ext=Open$ ,  $V_{ovp}=Open$ ,  $V_{fb}=GND$ ,  $C_X=300pF$ ,  $V_{En}=V_{in}$ ,  $T_a=25^{\circ}C$  unless otherwise specified

| Parameter  | Symbol                             | Value |       |       | Units | Conditions  |
|--|------------------------------------|-------|-------|-------|-------|---|
|  |                                    | MIN   | TYP   | MAX   |       |   |
| <b>Oscillator Section (C<sub>X</sub> Pin)</b>                  |                                    |       |       |       |       |   |
| C <sub>X</sub> Charging Current                                | I <sub>chg</sub>                   | 16    | 22    | 30    | μA    | V <sub>Cx</sub> =0.1V, V <sub>fb</sub> =1V                    |
| C <sub>X</sub> Discharging Current                             | I <sub>dis</sub>                   | 35    | 49    | 65    | μA    | V <sub>Cx</sub> =1.0V, V <sub>fb</sub> =1V                    |
| Charge and Discharge Current Ratio                             | I <sub>dis</sub> /I <sub>chg</sub> |       | 2.2   |       |       |   |
| C <sub>X</sub> Threshold Voltage +                             | V <sub>Cx, High</sub>              | 810   | 860   | 910   | mV    | V <sub>Cx</sub> at I <sub>chg</sub> =0uA, V <sub>fb</sub> =1V |
| C <sub>X</sub> Threshold Voltage -                             | V <sub>Cx, Low</sub>               | 260   | 300   | 340   | mV    | V <sub>Cx</sub> at I <sub>dis</sub> =0uA, V <sub>fb</sub> =1V |
| C <sub>X</sub> Oscillation Voltage                             | V <sub>OSC</sub>                   | 520   | 560   | 600   | mV    | (V <sub>Cx, High</sub> )-(V <sub>Cx, Low</sub> )              |
| <b>Current Limiting Comparator Section (I<sub>s</sub> Pin)</b> |                                    |       |       |       |       |   |
| Inductor Current Limit   | I <sub>LIMIT</sub>                 | 220   | 260   | 300   | mA    | Note 1  |
| Pin 1-2 total Resistance                                       | R <sub>scext</sub>                 | 380   | 440   | 500   | mΩ    | Measured Between pin 1 and pin 2                              |
| Internal effective Resistance for Inductor Current Limit Sense | R <sub>sc</sub>                    |       | 300   |       | mΩ    | Note 2, Note 3  |
| <b>Output Switch Section (Ext Pin)</b>                         |                                    |       |       |       |       |   |
| Output Transistor Saturation Voltage                           | V <sub>sw, Sat</sub>               |       | 0.2   | 0.4   | V     | V <sub>Cx</sub> =0V, I <sub>sw</sub> =200mA                   |
| Output Transistor Off Leak Current                             | I <sub>sw, Off</sub>               |       | 0.01  | 2     | μA    | V <sub>fb</sub> =1V, V <sub>sw</sub> =20V                     |
| <b>Feedback Comparator Section (Vfb Pin)</b>                   |                                    |       |       |       |       |   |
| Reference Voltage  | V <sub>ref</sub>                   | 0.495 | 0.515 | 0.535 | V     |   |
| Vfb Pin Output Current   | I <sub>fbIn</sub>                  | -2    | -0.3  |       | μA    | V <sub>fb</sub> =0.4V   |
| <b>Shutdown Section (En Pin)</b>                               |                                    |       |       |       |       |   |
| En Input Voltage +   | V <sub>En, High</sub>              | 1.2   |       | 20    | V     | On mode   |
| En Input Voltage -   | V <sub>En, Low</sub>               |       |       | 0.3   | V     | Shutdown mode   |
| En Pin Input Bias Current                                      | I <sub>EnIn</sub>                  |       | 25    | 40    | μA    | V <sub>En</sub> =3V   |
| <b>Open-Circuit Protection Section (Vovp Pin)</b>              |                                    |       |       |       |       |   |
| Open-Circuit Voltage   | V <sub>OVP</sub>                   | 17    | 18.5  | 20    | V     | I <sub>z</sub> =0.5mA   |
| <b>Vin Section (Vin Pin)</b>                                   |                                    |       |       |       |       |   |
| Low Voltage Stop   | V <sub>in, Low</sub>               | 1.7   | 2.0   | 2.3   | V     |   |
| High Voltage Output Stop                                       | V <sub>in, High</sub>              | 11.5  | 13.5  | 14.5  | V     |   |
| Shutdown Supply Current  | I <sub>in, Off</sub>               |       | 0.01  | 1     | μA    | V <sub>En</sub> =0.3V   |
| Quiescent Supply Current                                       | I <sub>in, On</sub>                | 1     | 1.5   | 2     | mA    | V <sub>fb</sub> =1V   |

Note 1 I<sub>LIMIT</sub>: The value of current source I<sub>L</sub> (DC measurement) when the switching operation is stopped by the Is comparator.

Note 2 R<sub>sc</sub>: Guaranteed by the design equation: 
$$I_{LIMIT} = \frac{0.1V - \frac{2.3}{300} V_{in}}{R_{sc}}$$

Note 3 Do not connect the output circuit to ground directly, the R<sub>sc</sub> might be damaged. (Excessive current passes through R<sub>sc</sub>, Schottky Diode and Coil)

10. TEST CIRCUIT

TEST CIRCUIT

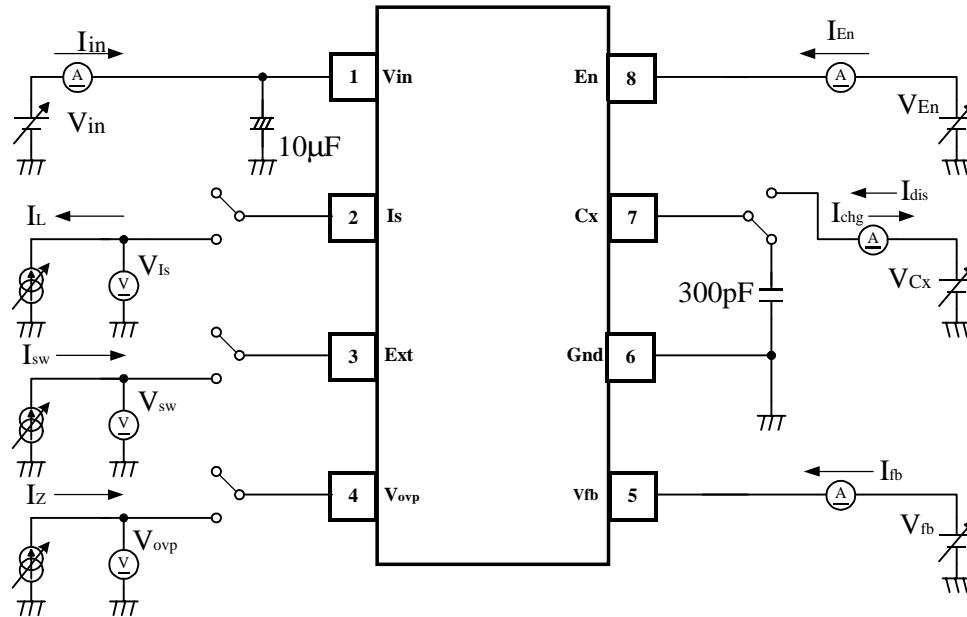

TEST CIRCUIT FOR EFFICIENCY MEASUREMENT. (REFERENCE ONLY)

Efficiency: 78%(typ)

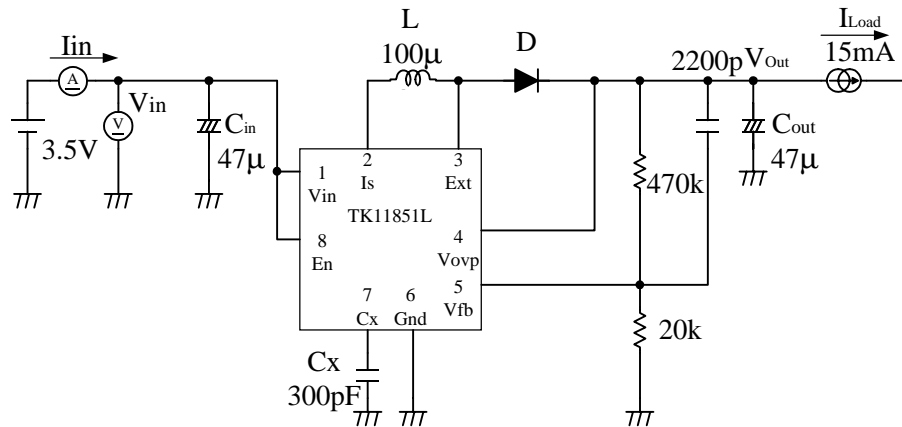

L: 100µH D63LCB (A921CY-101M) TOKO  
 D: SB07-03C SANYO

**11. TYPICAL CHARACTERISTICS**

**OSC Period time vs.  $C_x$  Capacitance**

$V_{in}=V_{En}=3V, V_{fb}=0V$

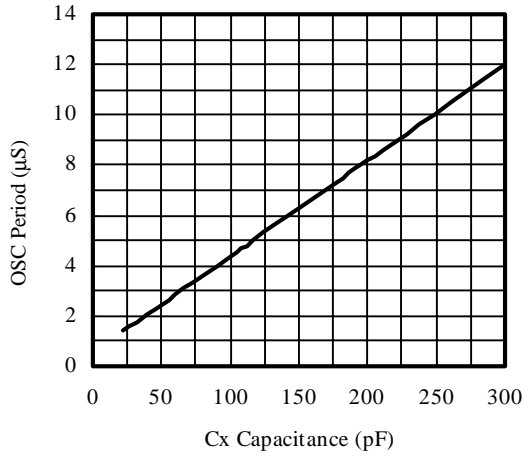

**OSC Frequency vs. Temperature**

$V_{in}=V_{En}, V_{fb}=0V, C_x=100pF$

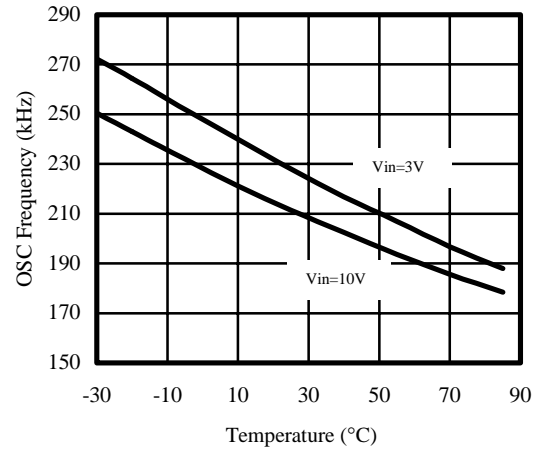

**Maximum Duty vs. OSC Frequency**

$V_{in}=V_{En}=3V, V_{fb}=0V$

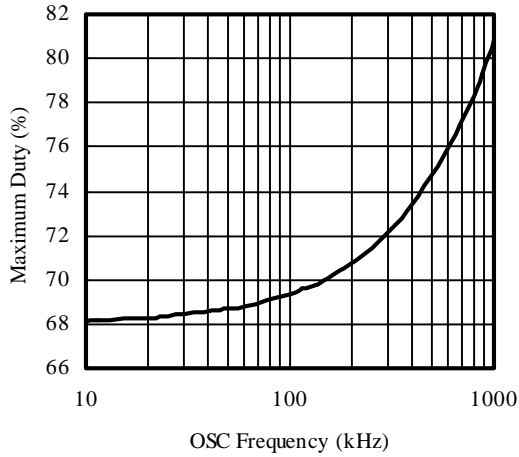

**Switch Current vs. Switch Saturation Voltage**

$V_{in}=V_{En}=3V, V_{fb}=0V, V_{Cx}=0V$

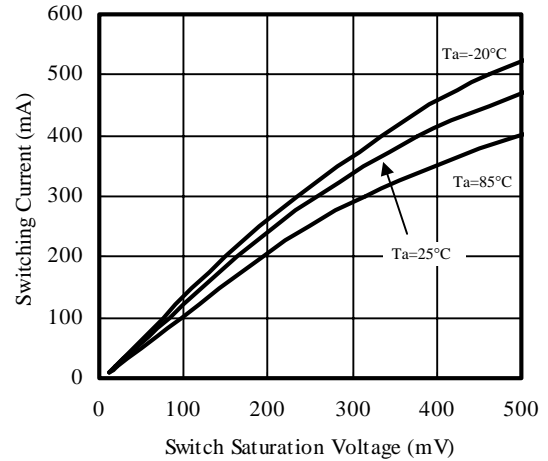

**Inductor Current Limit vs. Supply Voltage**

$V_{En}=V_{in}, V_{fb}=0V, V_{Cx}=0V$

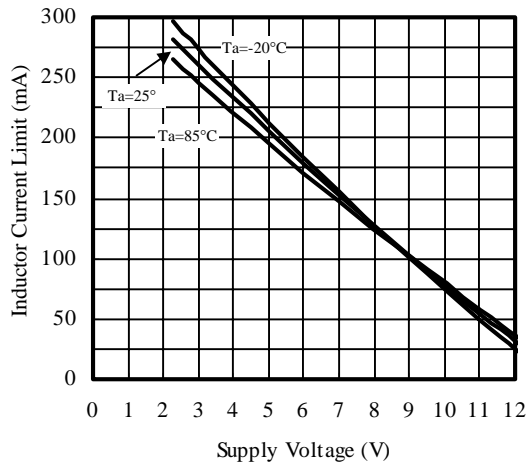

**Pin 1-2 total Resistance vs. Temperature**

$(V_{in}-V_{is})/I_L, I_L=100mA$

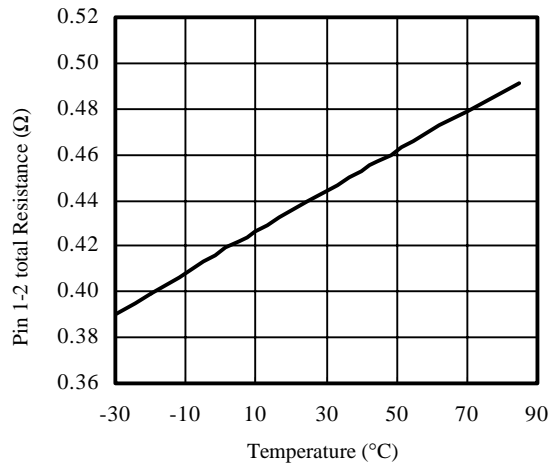



**Reference Voltage vs. Supply Voltage**

$V_{in}=V_{En}, V_{Cx}=0V$

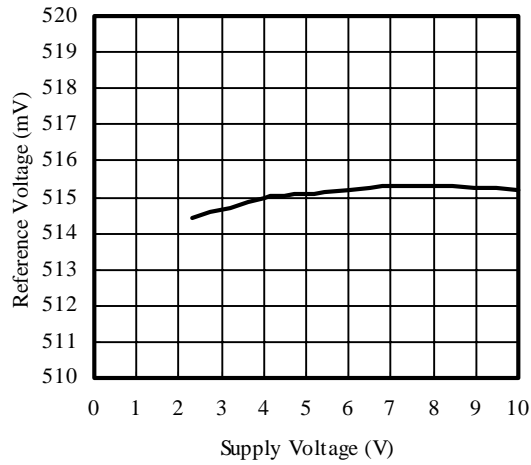

**Reference Voltage vs. Temperature**

$V_{in}=V_{En}=3V, V_{Cx}=0V$

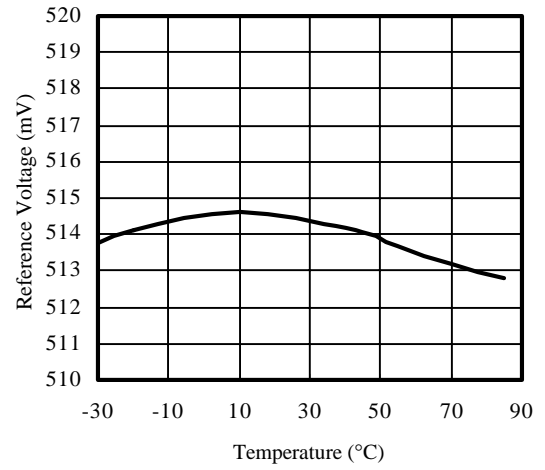

**Supply Current vs. En Input Voltage**

$V_{in}=3V, V_{fb}=0V, C_X=100pF$

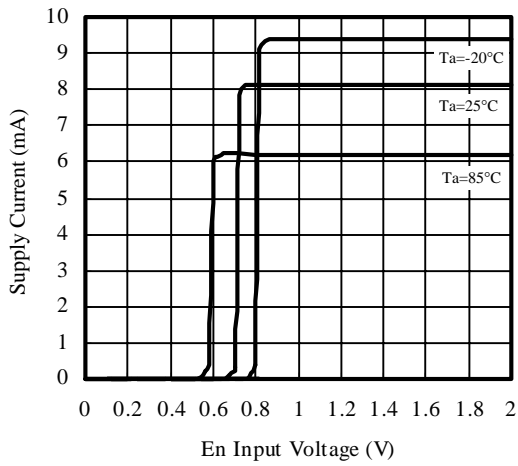

**Supply Current vs. En Input Bias Current**

**(En pin current force)  $V_{in}=3V, V_{fb}=0V, C_X=100pF$**

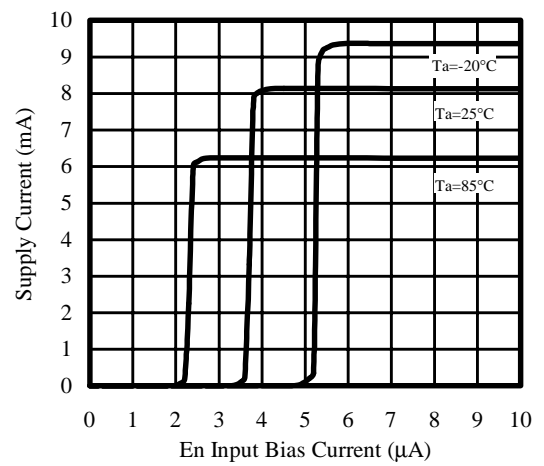

**En Input Bias Current vs. En Input Voltage**

$V_{in}=3V, V_{fb}=0V$

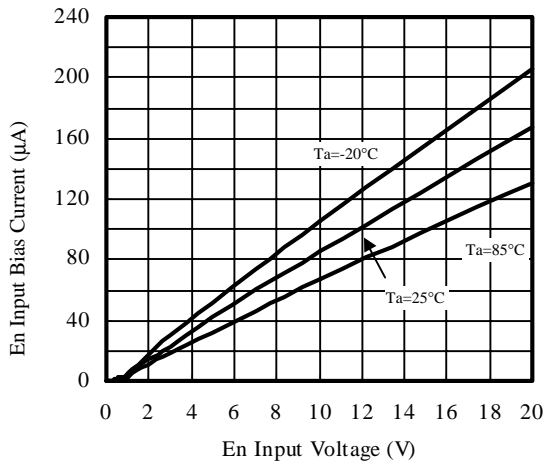

**Zener Diode Current vs. Open-Circuit Voltage**

$V_{in}=3V, V_{fb}=0V, V_{En}=0.3V$

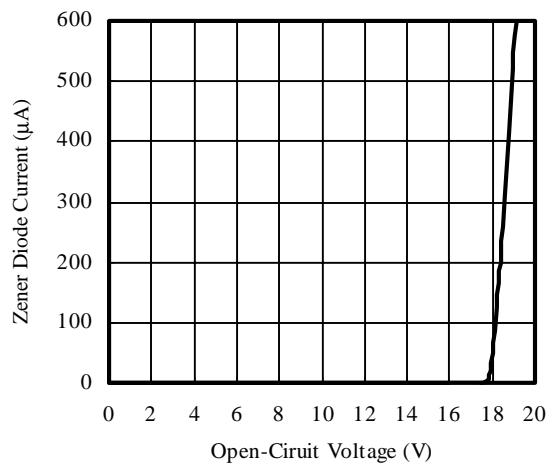

**Open-Circuit Voltage vs. Temperature**

$V_{in}=3V, V_{En}=0.3V, I_z=500\mu A$

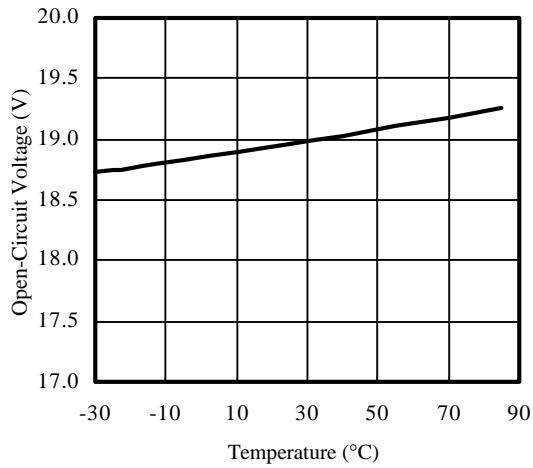

**Shutdown Supply Current vs. Supply Voltage**

$V_{in}=V_{En}, V_{En}=0.3V$

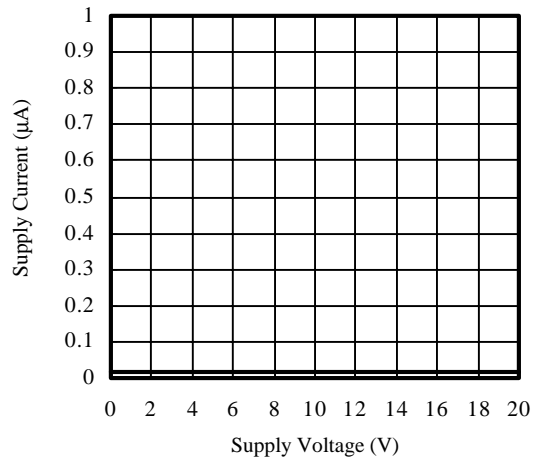

**Quiescent Supply Current vs. Supply Voltage**

$V_{En}=V_{in}, V_{fb}=1V, C_x=100pF$

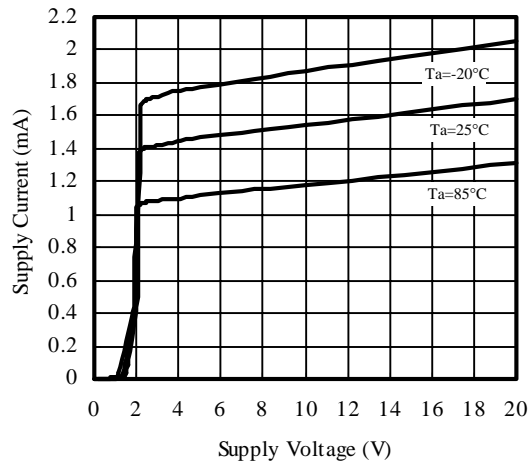

12. PIN DESCRIPTION

| PIN No. | SYMBOL         | INTERNAL EQUIVALENT CIRCUIT | DESCRIPTION   |
|---------|----------------|-----------------------------|---|
| 1       | Vin            |                             | Power supply voltage input.   |
| 2       | Is             |                             | The function of this pin is to limit the inductor current associated with the Is comparator. The device contains a sensing resistor referenced as "R <sub>sc</sub> ". The value of R <sub>sc</sub> is 0.3Ω (typ). Because there is also bonding-wire resistance, it will be approximately 0.44Ω when measured between pin1 and pin 2. |
| 3       | Ext            |                             | This pin is the collector of the internal 20V NPN power switch. The switch transistor has a maximum peak current capability of 400mA and a turn-off delay of 0.2μSec.   |
| 4       | Vovp           |                             | This pin will work as open-circuit protection. Connect Vovp to Output (Vout) to avoid generating high voltage at the switch pin during open-circuit conditions. The zener voltage is approximately 18V.   |
| 5       | Vfb            |                             | Feedback input pin<br>This pin is the non-inverting input of the error comparator with the inverting input biased with the internal temperature-compensated 0.515V reference. The input bias current of Fb has a typical value of -0.3μA.   |
| 6       | Gnd            |                             | Ground.   |
| 7       | Cx             |                             | The oscillator frequency is determined by the external timing capacitor C <sub>x</sub> and can be set up to 800kHz maximum. The timing capacitor is the only component allowed to be connected to this pin.   |
| 8       | En<br>(On/Off) |                             | This is the chip-enable input with a built-in 200kΩ pull-down resistor. Set the En-pin higher than 1.2V to enable the device. Set the En-pin below 0.3V to disable the device.  |

13. CIRCUIT DESCRIPTION

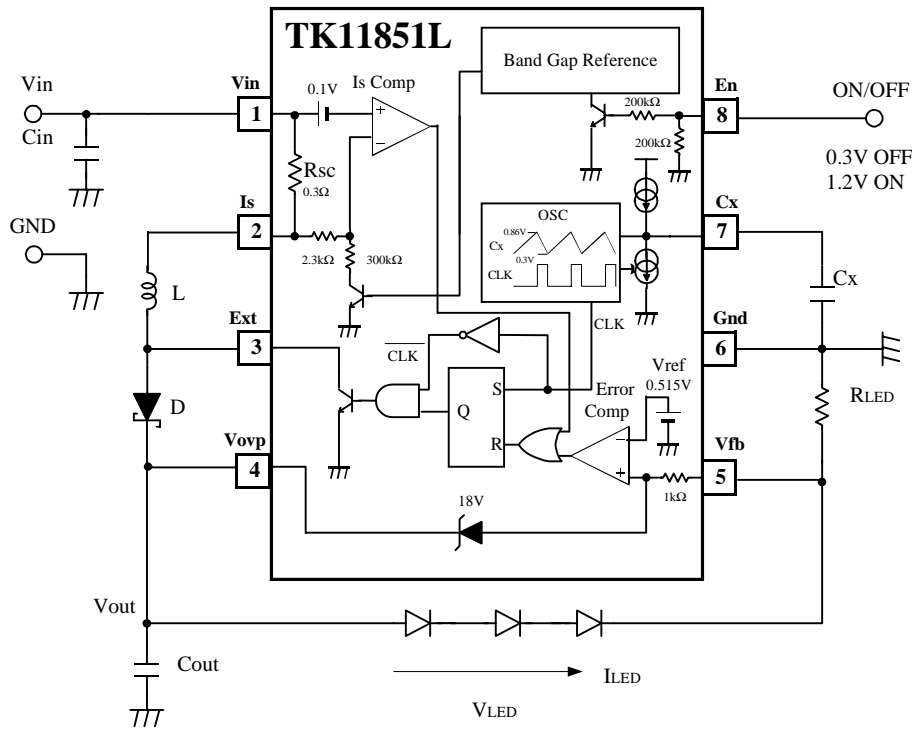

TK11851L Block Diagram

13-1. Constant-Current (Charge and discharge type) Oscillator.

The oscillator operates by charging and discharging the timing capacitor \$C\_x\$. This generates the linear ramp waveform across \$C\_x\$ and the internal squarewave signal of the IC. The period time \$T\$ of the oscillator is determined by the choice of the timing capacitor \$C\_x\$ and is set according to the following equation.

$$T_{(\mu sec)} = 0.038(C_x + 15)_{(pF)} \quad (1)$$

The oscillator output signal "CLK" is a fixed-duty-cycle pulse train, whose on-off time is fixed internally at a ratio of 2.2:1

$$\frac{t_{chg}}{t_{dischg}} \approx 2.2 \quad (2)$$

The period time of the oscillator is the period of one full cycle of operation.

$$T = t_{chg} + t_{dischg} \quad (3)$$

$$f_{osc} = \frac{1}{T} \quad (4)$$

The oscillator frequency can be set up to 800kHz.

The internal squarewave (CLK) is logical high during the \$t\_{dischg}\$ of ramping down and is low during the \$t\_{chg}\$ of ramping up. When CLK goes high and the AND gate output is low, the switch transistor will be forced off. At the same time, the R-S flip-flop is set to prepare for the next on cycle. When CLK goes low, the inverting signal (\$\overline{CLK}\$) and the output \$Q\$ of the flip-flop enters the AND gate; then the AND gate output is high and the switch transistor will be on.

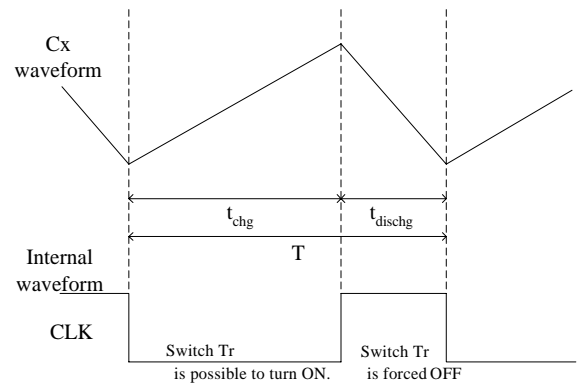

Figure 1: OSC Waveforms

### 13-2. Inductor Current Limit

The Inductor current-limit function associated with the Is comparator is accomplished by sensing the inductor current by means of the voltage drop across the internal resistor  $R_{sc}$ .

The voltage drop across  $R_{sc}$  is compared with the equivalent reference voltage of the Is comparator ( $V_{LIMIT}$ ). If the inductor peak current exceeds the limit, the Is comparator output resets the flip-flop and the switch transistor will be forced off.

The limited value of the inductor peak current can be expressed as

$$I_{Lpk,LIMIT} = \frac{V_{LIMIT}}{R_{sc}} + \frac{V_{in} - V_{sat}}{L} t_d \quad (5)$$

Where

$V_{LIMIT}$  : Equivalent reference voltage of Is comparator.

$R_{sc}$  : Effective current-sense resistor, which is set to  $0.3\Omega$ .

$V_{in}$  : Supply input voltage.

$V_{sat}$  : Switch transistor saturation voltage.

$L$  : Inductor value.

$t_d$  : Turn-off delay of switch transistor, which is  $0.2\mu\text{sec}$ .

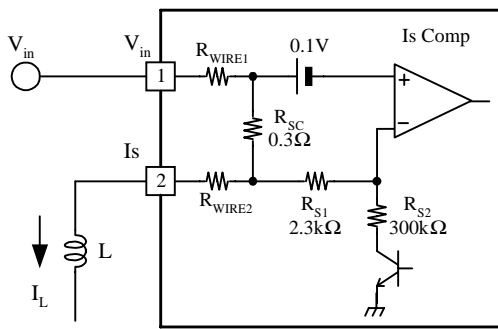

Figure 2: Schematic of the Inductor Current Limit

In the right side of the equation, the 1st term expresses the limitation by the Is comparator and the 2nd term is an additional inductor current caused by the turn-off delay of the switch transistor. The internal equivalent reference voltage of the Is comparator  $V_{LIMIT}$  depends on the supply voltage  $V_{in}$  with resistors  $R_{S1}$  and  $R_{S2}$ , and can be written as

$$V_{LIMIT} \approx 0.1V - \frac{2.3}{300} V_{in} \quad (6)$$

Therefore, the inductor current limitation  $I_{LIMIT}$  from the 1st term can be given as

$$I_{LIMIT} = \frac{V_{LIMIT}}{R_{sc}} = \frac{1}{R_{sc}} \left( 0.1V - \frac{2.3}{300} V_{in} \right) \quad (7)$$

(As an example,  $I_{LIMIT}=256\text{mA}$  at  $V_{in}=3\text{V}$ )

When the voltage drop across  $R_{sc}$  reaches the  $V_{LIMIT}$ , the switch transistor will be forced off, but there is turn-off delay of the switch transistor ( $t_d=0.2\mu\text{Sec}$ ); the additional inductor peak current is expressed as the 2nd term of equation (5).

$$\left( \begin{array}{l} \text{As an example} \\ t_d=0.2\mu\text{Sec}, V_{in}=3\text{V}, L=22\mu\text{H}, V_{sat}=0.3\text{V} \\ \Delta I_{Lpk} = \frac{V_{in} - V_{sat}}{L} t_d = 30\text{mA} \end{array} \right)$$

As a result, the total amount of inductor peak current is limited by equation (5).

$$\left( \begin{array}{l} \text{For Example} \\ t_d=0.2\mu\text{Sec}, V_{in}=3.0\text{V}, L=22\mu\text{H}, V_{sat}=0.3\text{V} \\ I_{Lpk,LIMIT}=256\text{mA} (1\text{st term})+30\text{mA} (2\text{nd term})=286\text{mA} \end{array} \right)$$

The equations (5), (6) and (7) shows that a higher supply voltage  $V_{in}$  will reduce the peak inductor current. This function will allow the use of an inductor with a physically smaller inductor core under a wide operating voltage range. When the supply voltage is higher than  $13.5\text{V}$ , the Is comparator output keeps the flip-flop reset (through the OR gate) and the switch transistor will turn-off constantly.

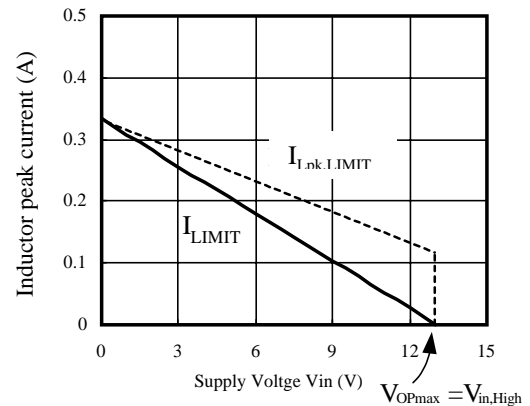

Figure 3: Inductor current limit  
As a function of Supply input voltage  
( $R_{sc}=0.3\Omega$ ,  $L=22\mu\text{H}$ ,  $V_{sat}=0.3\text{V}$ )

**To increase the inductor peak current**

If it is necessary to get more output power, add the external resistor  $R_{scout}$  between pin 1 and pin 2 in parallel with the internal resistor  $R_{sc}$  to increase the inductor peak current. Then, the inductor current limit can be expressed as

$$I_{Lpk,LIMIT} = \left(1 + \frac{R_{scext}}{R_{scout}}\right) I_{LIMIT} + \frac{V_{in} - V_{sat}}{L} t_d \quad (8)$$

Where

$R_{scext}$ : Internal resistor measured pin 1-pin 2.

$$(R_{scext} = R_{WIRE1} + R_{WIRE2} + R_{sc} = 0.44\Omega)$$

$R_{scout}$ : External resistor.

$I_{LIMIT}$ : defined in equation (7).

$\frac{V_{in} - V_{sat}}{L} \cdot t_d$ : Defined as the 2nd term in equation (5).

As an example  
 $R_{scout} = 2.2\Omega$ ,  $V_{in} = 3.0V$ ,  $L = 22\mu H$   
 $V_{sat} = 0.3V$ ,  $t_d = 0.2\mu Sec$   
 $I_{Lpk,LIMIT} = 340mA$

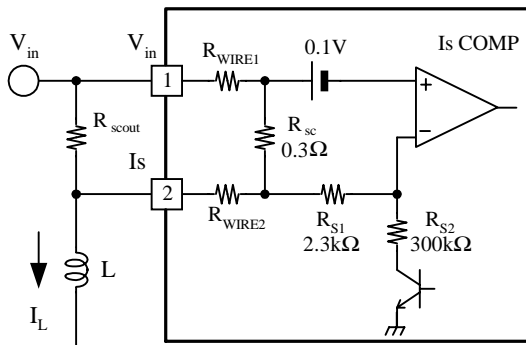

Figure 4: Increased inductor current limit with  $R_{scout}$

**13-3. En (On/Off)**

Set the En pin higher than 1.2V to enable the device. Set it below 0.3V to disable the device; that is, shutdown mode. During shutdown, the supply current drops to 1μA or less. The internal 200kΩ pull-down resistor ensures the shutdown mode when the En pin remains open. The En pin can be pulled up to 20V, regardless of the supply voltage and output voltage. The relationship between control current ( $I_{En}$ ) and En pin voltage ( $V_{En}$ ) is

$$I_{En} = \frac{V_{En}}{R_{down}} + \frac{V_{En} - V_{BE}}{R_{En}} \quad (9)$$

Where  $R_{down} = R_{En} = 200k\Omega$ ,  $R_{EnOUT} = 0\Omega$

If the voltage applied to the En pin is too high, put  $R_{EnOUT}$  in series with the En pin to reduce its bias current.

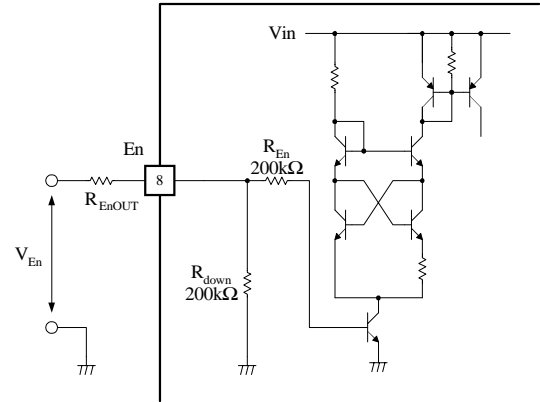

Figure 5: Internal equivalent circuit of En pin

The En pin is also used to provide LED-dimming (see DIMMING).

**13-4. Operating supply voltage range**

When the supply voltage falls below 2.0V ( $V_{in,Low}$ ), the TK11851L stops switching operation to avoid malfunction. The level of  $V_{in,Low}$  is determined by the internal circuit. When the supply voltage is above 13.5V ( $V_{in,High}$ ), the TK11851L also stops switching operation because of the limitation from equation (7). However, the maximum rating for the supply voltage is as high as 20V.

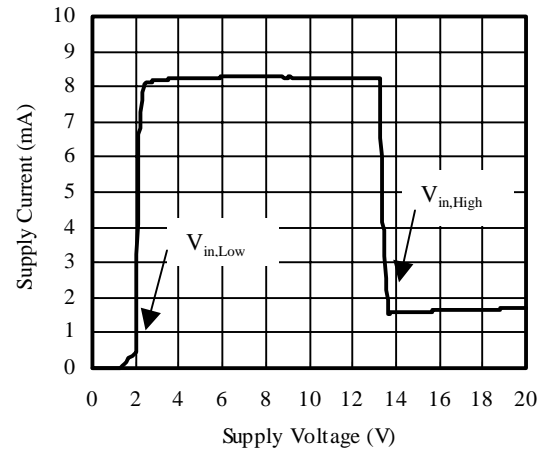

Figure 6: Operating supply voltage range ( $V_{En} = V_{in}$ ,  $V_{fb} = 0V$ ,  $C_X = 100pF$ )

### 13-5. Error comparator, Vfb

The error comparator section of the circuit compares the output feedback voltage Vfb with the 0.515V internal reference and generates a reset signal which inhibits the oscillator output from turning the switch transistor on whenever the output voltage is too high (see block diagram). In this manner, the drive to the switch transistor is essentially an intermittent pulse train, as a result of the pulse skipping operation.

This architecture allows the series-connected white LEDs to be driven with a constant current. The LED current (ILED) is set by an external resistor (RLED) connected between the feedback pin and GND (see Figure 7). The current of each LED is

$$I_{LED} = \frac{V_{ref}}{R_{LED}} \quad (10)$$

Where Vref : the feedback reference voltage 0.515V

Output voltage Vout is given by

$$V_{out} = n \cdot V_f + V_{ref} \quad (11)$$

Where Vf : LED forward voltage drop

n : Number of LEDs connected in series

The maximum number of LEDs connected in series (n) is four.

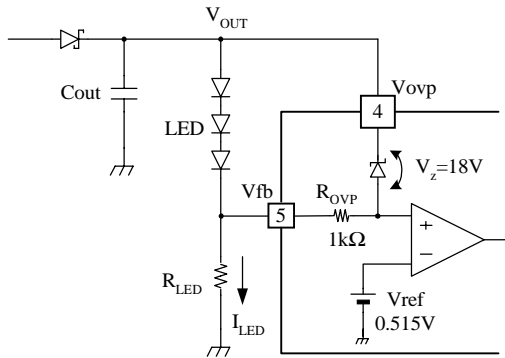

Figure 7: Setting constant current through LED

To obtain a regulated output voltage for most common step-up regulator applications, connect a voltage divider from the output (Vout) to Vfb (see Figure 8). The regulated output voltage is determined by

$$V_{out} = V_{ref} \left( 1 + \frac{R2}{R1} \right) \quad (12)$$

Vout ranges from Vin to 16.5V, with open-circuit protection connecting Vovp to Vout directly.

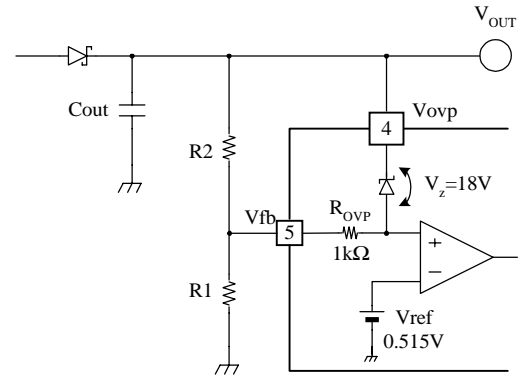

Figure 8: Setting output voltage

### 13-6. Open-Circuit Protection

The TK11851L has open-circuit protection by connecting the Vovp pin to the output voltage Vout. When the main feedback loop is opened, the internal zener diode will work as another path of the feedback loop. This prevents the switch node from generating high voltage. The voltage level at Vout is clamped at

$$V_{out} = V_{OVP} = V_z + V_{ref} = 18.5V$$

Where Vz=18V zener voltage

Vref=0.5V error comparator reference voltage.

During open-circuit, the current of zener diode Iz is

$$I_z = \frac{V_{ref}}{R_{OVP} + R_{LED}} \approx \frac{V_{ref}}{R_{OVP}} < 0.5mA \quad (13)$$

Where ROVP=1kΩ, ROVP >> RLED

The clamped level of Vout is enough to drive 4 white LEDs connected in series.

### 13-7. Relationship between Supply input voltage and Inductor peak current

The TK11851L is a pulse skipping step-up DC-DC converter where the inductor peak current is limited by the period time of the oscillator and the inductor current limit circuit. From the equation (1), the period time (T) of the oscillator is

$$T_{(\mu\text{sec})} = 0.038(C_X + 15)_{(\text{pF})} \quad (1)$$

Also, the switch on time derived from oscillator equation (1) through equation (3) is

$$t_{\text{on}} = t_{\text{chg}} + t_d = \frac{2.2}{3.2} T + t_d \quad (14)$$

Then, the inductor peak current from the oscillator circuit is written as

$$I_{Lpk} = \frac{V_{\text{in}} - V_{\text{sat}}}{L} \left( \frac{2.2}{3.2} T + t_d \right) \quad (15)$$

This equation (15) shows that when  $V_{\text{in}}$  increases,  $I_{Lpk}$  will increase linearly. If  $I_{Lpk}$  (given by equation (15)) reaches the value of the inductor current limit, the inductor peak current limited by the inductor current limit circuit is expressed as equation (5).

$$I_{Lpk,LIMIT} = \frac{V_{LIMIT}}{R_{sc}} + \frac{V_{\text{in}} - V_{\text{sat}}}{L} t_d$$

$$= \frac{1}{R_{sc}} \left( 0.1V - \frac{2.3}{300} V_{\text{in}} \right) + \frac{V_{\text{in}} - V_{\text{sat}}}{L} t_d \quad (5)$$

Equation (5) shows that when  $V_{\text{in}}$  increases,  $I_{Lpk}$  will decrease linearly.

As a result, the inductor peak current can be plotted in Fig(10) over a wide range of supply voltage input.

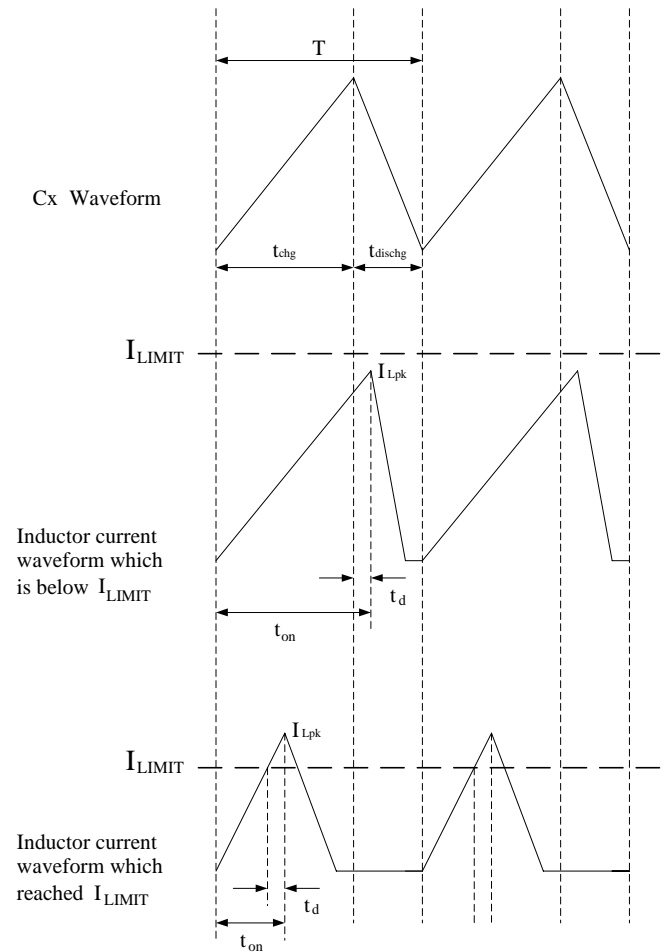

Figure 9: Inductor current waveform

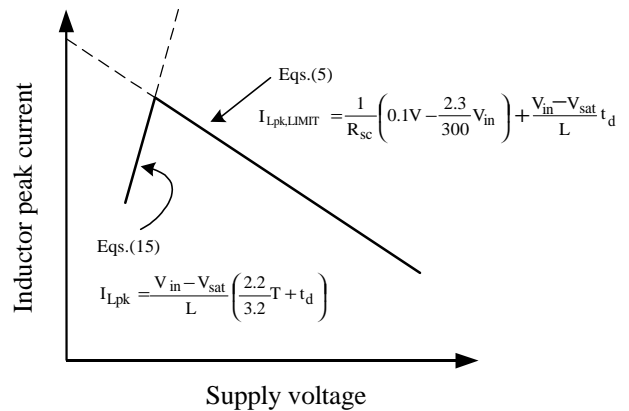

Figure 10: Plot of Inductor peak current as a function of supply voltage



13-8. DIMMING

The following are 3 kinds of methods.

1. Dimming by R<sub>LED</sub>

The current of the LED (I<sub>LED</sub>) is determined by R<sub>LED</sub>, which can be set by switches such as transistors.

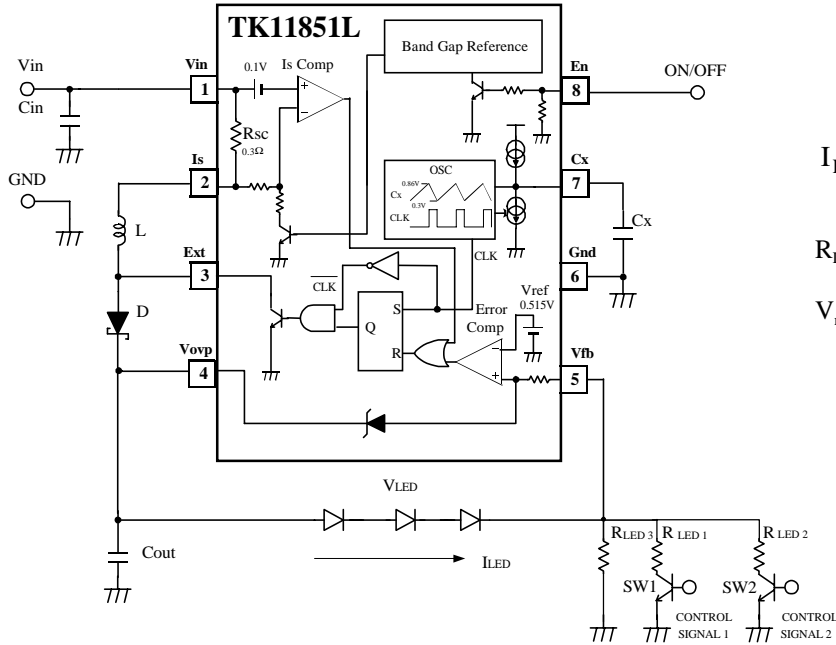

$$I_{LED} = \frac{V_{ref}}{R_{LED}}$$

R<sub>LED</sub>: Total value of Resistors

V<sub>ref</sub>=0.515V(typ)

Figure 11: Example of 3LEDs with a 4 brightness level circuit

The current of the LED can be approximated as

|   | SW 1 | SW 2 | I <sub>LED</sub>                                   |
|---|------|------|--|
| 1 | ON   | ON   | $\frac{V_{ref}}{R_{LED1} // R_{LED2} // R_{LED3}}$ |
| 2 | ON   | OFF  | $\frac{V_{ref}}{R_{LED3} // R_{LED1}}$             |
| 3 | OFF  | ON   | $\frac{V_{ref}}{R_{LED3} // R_{LED2}}$             |
| 4 | OFF  | OFF  | $\frac{V_{ref}}{R_{LED3}}$                         |

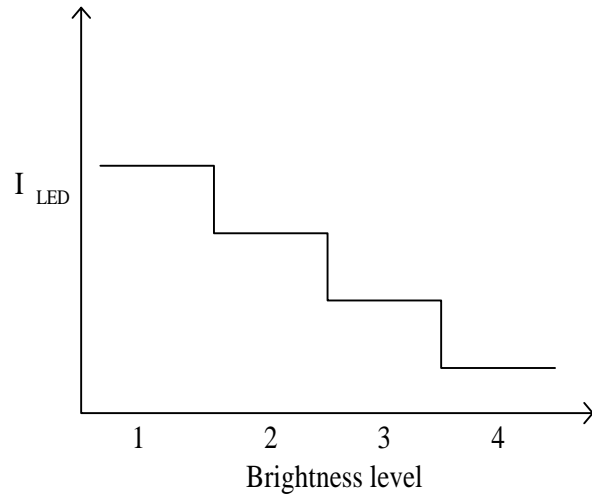

## 2. Dimming by DAC (D/A Converter) output

Dimming is achievable by applying a DAC output to the Vfb terminal with addition of  $R_{DAC1}$  and  $R_{DAC2}$

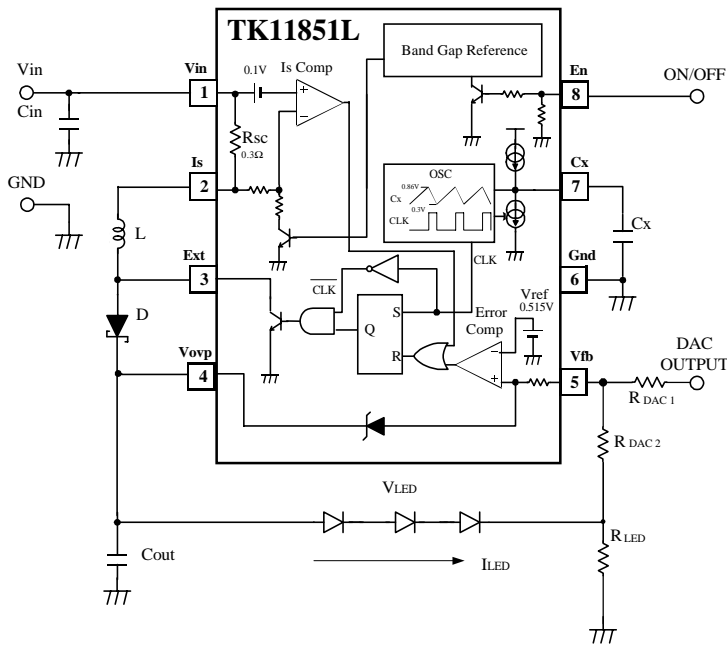
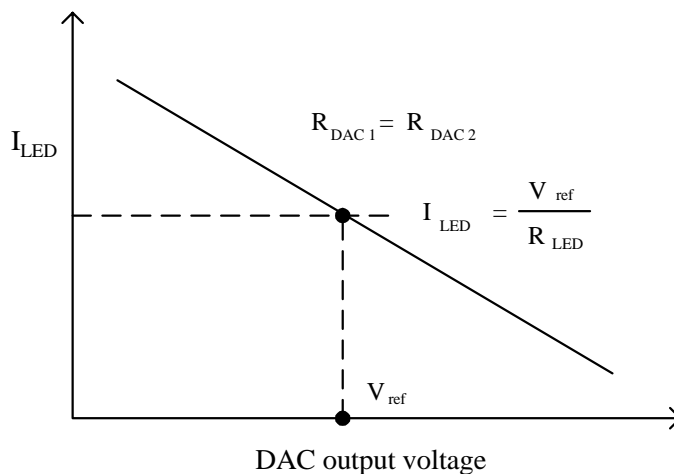

Figure 11: Dimming by DAC (D/A Converter) output

The current of the LED can be given as

$$I_{LED} = \frac{1}{R_{LED}} \left\{ V_{ref} - \frac{R_{DAC2}}{R_{DAC1}} (V_{DACOUT} - V_{ref}) \right\} \quad \text{Where } V_{ref}=0.515V(\text{typ})$$

$$= \frac{1}{R_{LED}} (2V_{ref} - V_{DACOUT}) \quad \text{Where } R_{DAC1}=R_{DAC2} \text{ is assumed}$$



### 3. PWM Dimming

Apply the PWM signal to the En terminal; (Pin no.8). In this case, a signal frequency of approximately 120 Hz is adequate. The average current of the LED changes due to the On/Off cycle of the IC, which follows the duty cycle of the PWM signal.

Set the PWM signal at a high level 1.2V and a low level 0.3V, with a driving current over 8μA

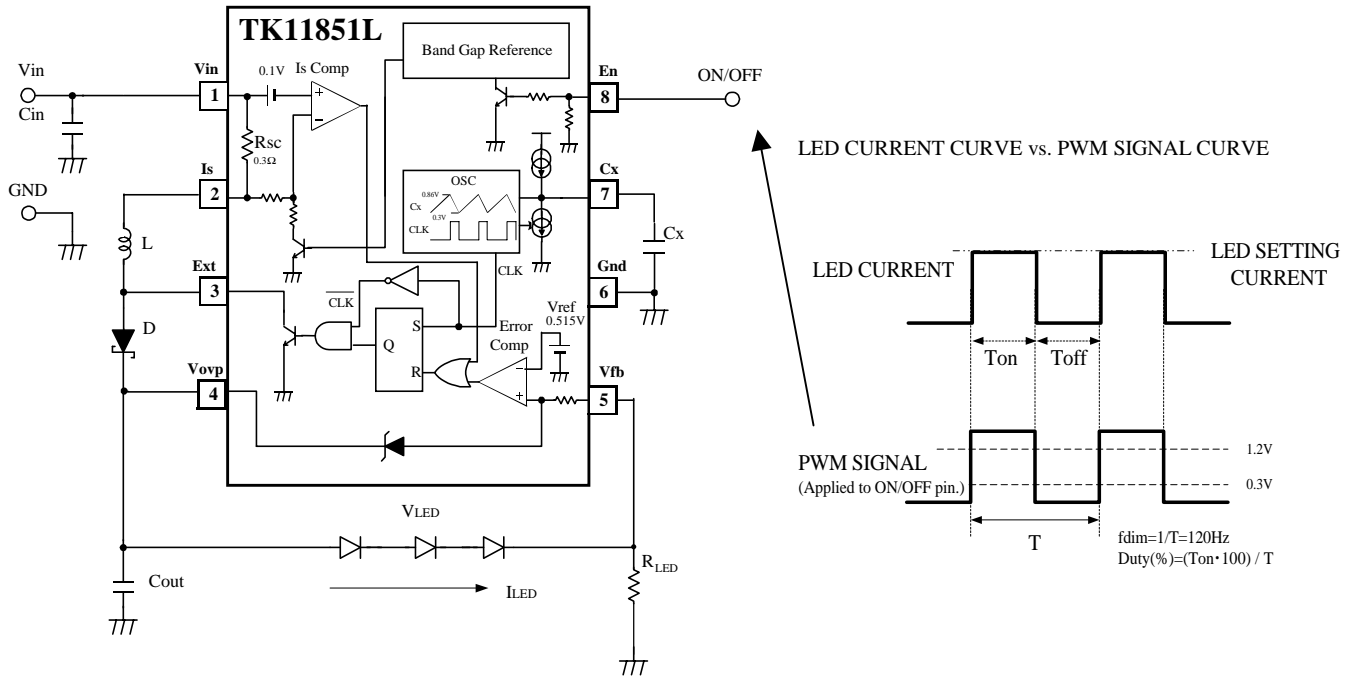
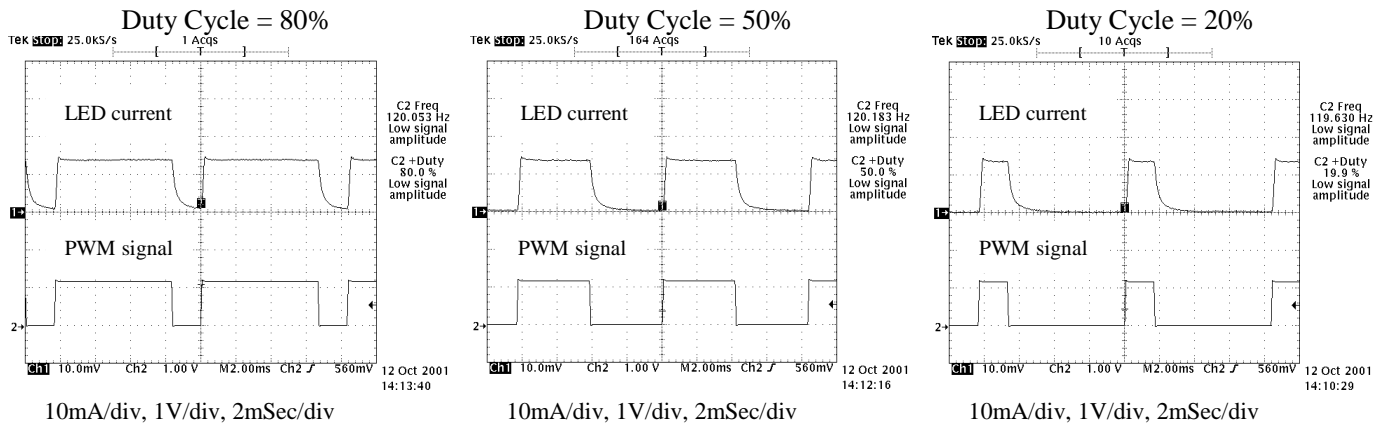

Figure 12: Dimming by PWM signal

The PWM dimming LED current follows the PWM signal. (As shown above)  
The average LED current is obtained from the formula below.

$$I_{LED(Avg)} = I_{LED(MAX)} \cdot \frac{Duty}{100} \quad \text{Where } I_{LED(MAX)} = \frac{V_{ref}}{R_{LED}}$$

The graph below shows an example with  $I_{LED MAX} 15mA$  at a Duty Cycle 80%, 50% and 20%.



Input PWM signal curve vs. LED current curve (ex. Three LEDs, LED current 15mA)

**14. WHITE LED APPLICATION**

**14-1. APPLICATION CIRCUIT (3 LEDs in Series)**

•LED Current: 13mA

L: 22μH Type D412F Toko Sample Number: 972AS-220M  
 Type D52LC Toko Sample Number A914BYW-220M

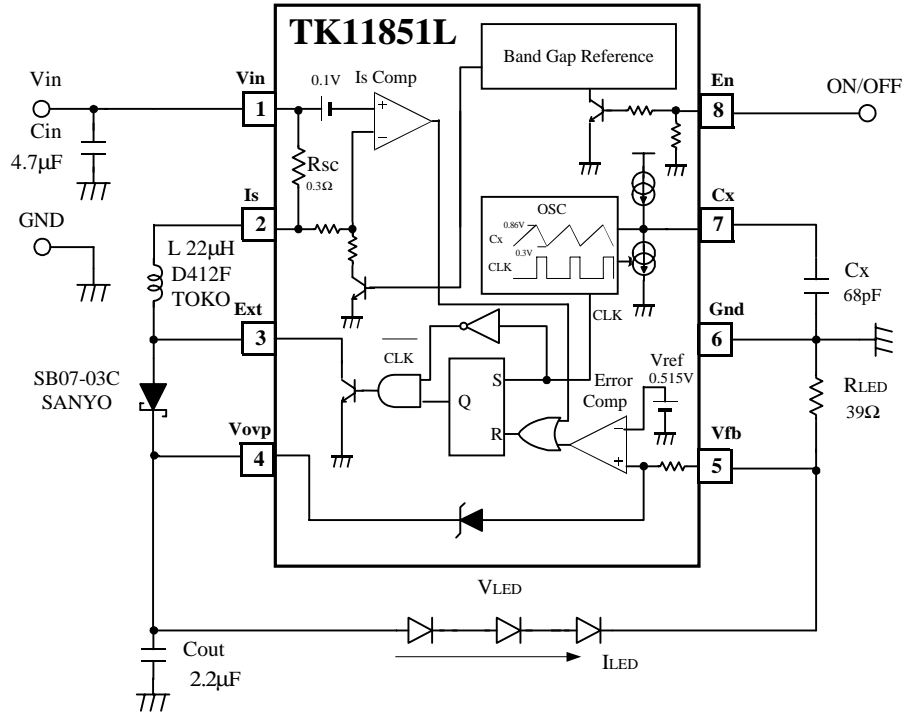

**LED Current and Efficiency Characteristics**

$$\text{Efficiency (\%)} = 100 \cdot V_{\text{out}} \cdot I_{\text{LED}} / (V_{\text{in}} \cdot I_{\text{in}})$$

Efficiency vs. Supply Voltage

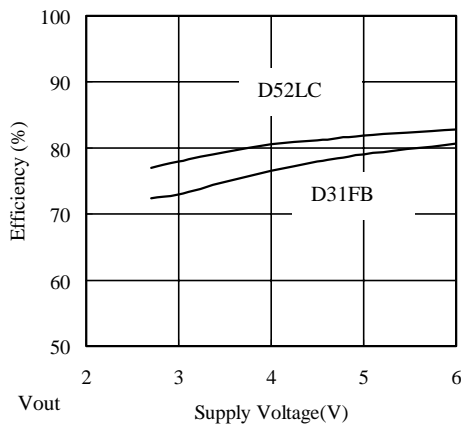

LED Current vs. Supply Voltage

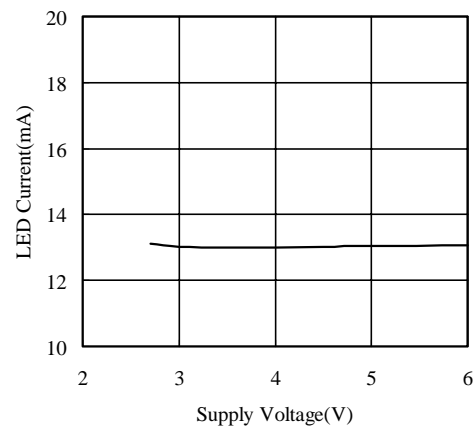

14-2. APPLICATION CIRCUIT (4 LEDs in Series)

•LED Current: 13mA

L: 15μH Type D412F Toko Sample Number: 972AS-150M  
 Type D52LC Toko Sample Number: A914BYW-150M

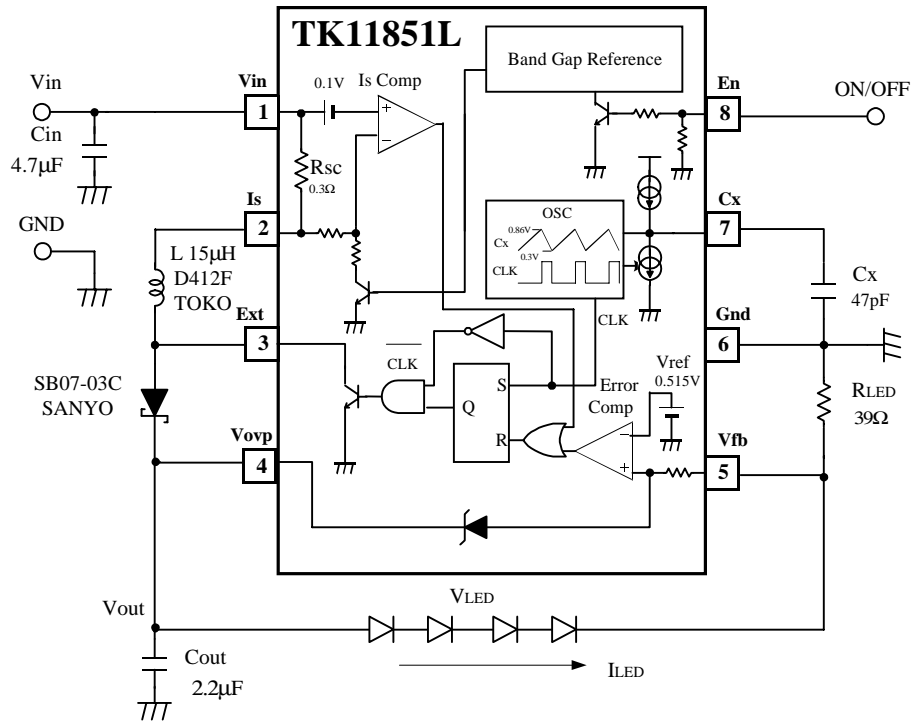

LED Current and Efficiency Characteristics

$$\text{Efficiency (\%)} = 100 \cdot V_{\text{out}} \cdot I_{\text{LED}} / (V_{\text{in}} \cdot I_{\text{in}})$$

Efficiency vs. Supply Voltage

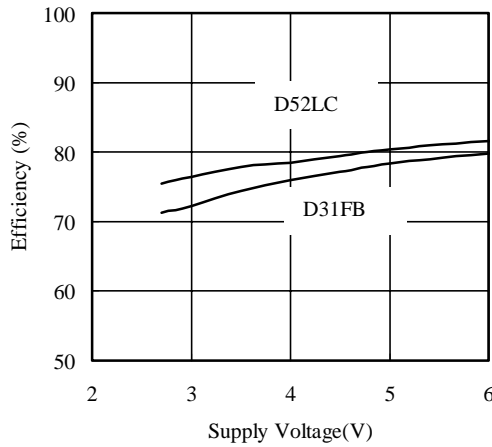

LED Current vs. Supply Voltage

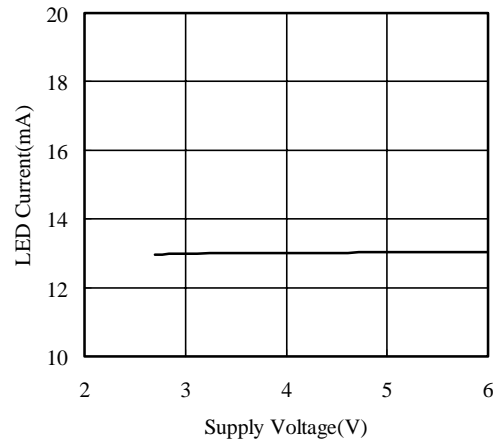

### 14-3. APPLICATION CIRCUIT (10 LEDs in 2 × (5 branches))

•Display Backlit Current: 13mA

Key Pad Current: Each branch 4mA

L: 22μH Type D412F Toko Sample Number: 972AS-220M

Type D52LC Toko Sample Number: A914BYW-220M

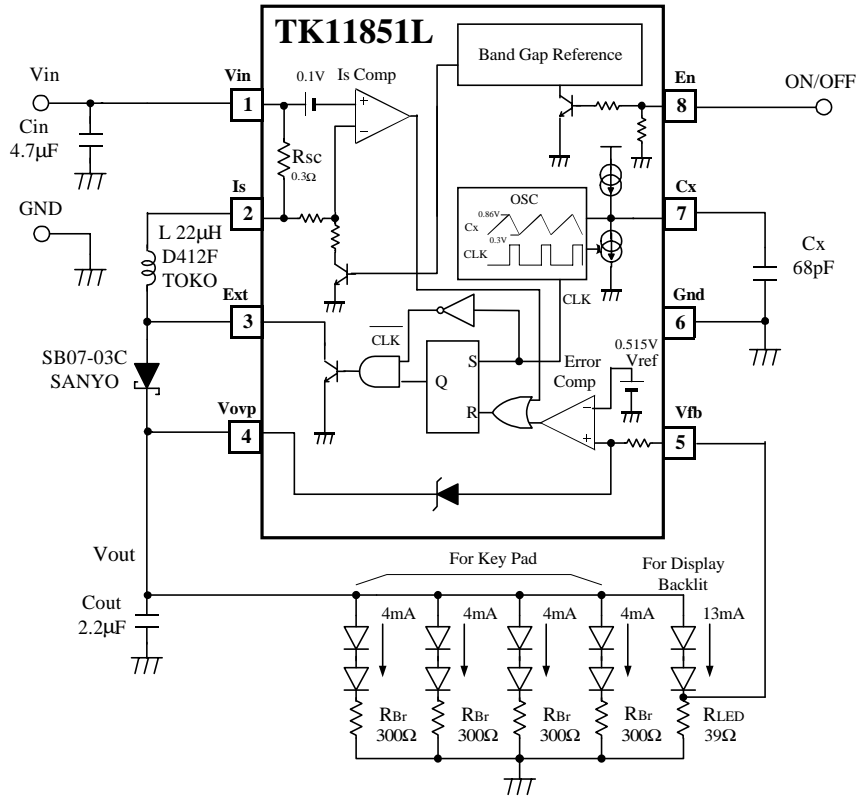

### LED Current and Efficiency Characteristics

$$\text{Efficiency (\%)} = 100 \cdot V_{\text{out}} \cdot I_{\text{LED}} / (V_{\text{in}} \cdot I_{\text{in}})$$

Efficiency vs. Supply Voltage

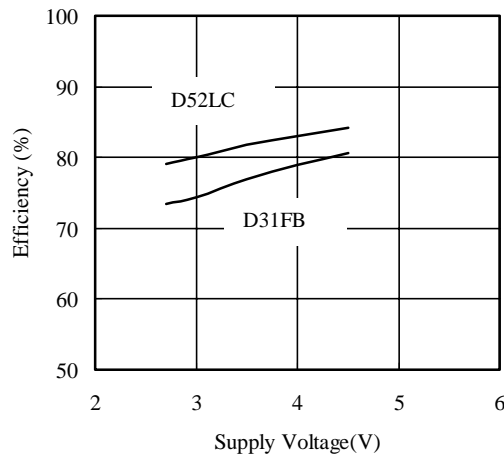

LED Current vs. Supply Voltage

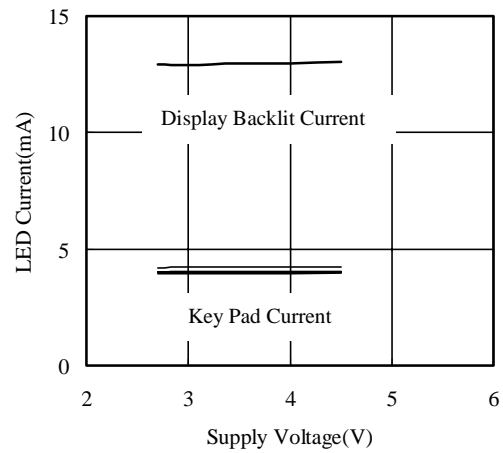

15. PACKAGE OUTLINE

SOT23L-8

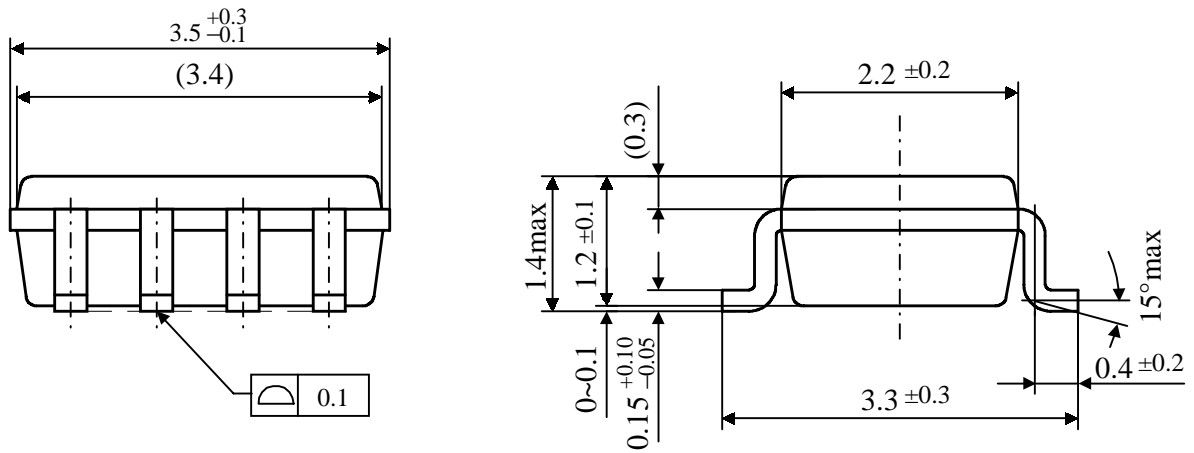
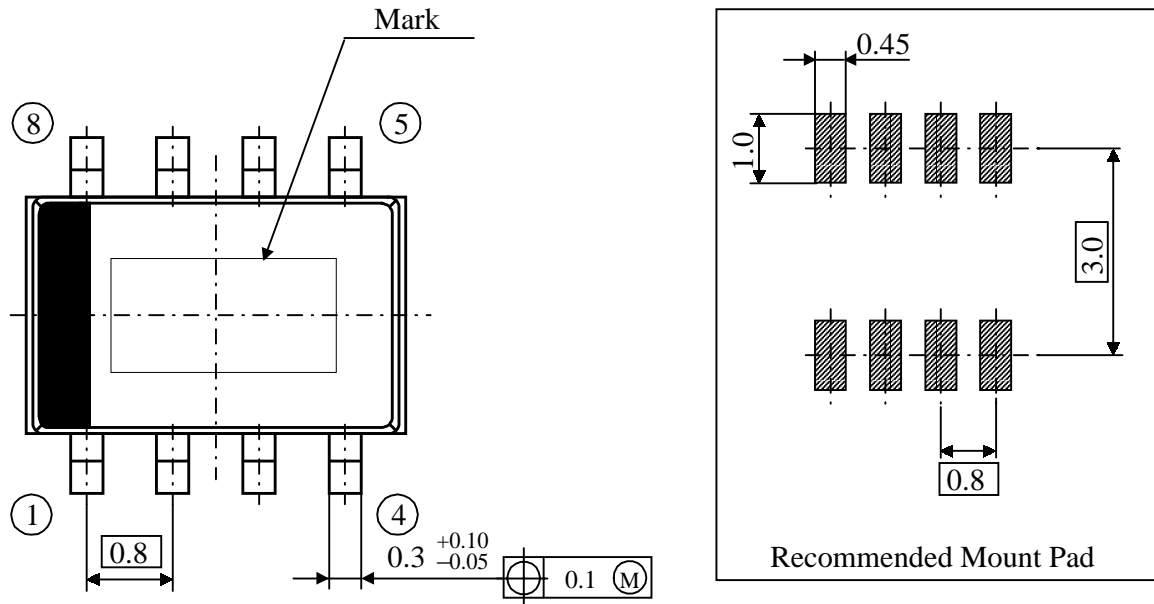

**16. NOTES**

■ Please be sure that you carefully discuss your planned purchase with our office if you intend to use the products in this application manual under conditions where particularly extreme standards of reliability are required, or if you intend to use products for applications other than those listed in this application manual.

- Power drive products for automobile, ship or aircraft transport systems; steering and navigation systems, emergency signal communications systems, and any system other than those mentioned above which include electronic sensors, measuring, or display devices, and which could cause major damage to life, limb or property if misused or failure to function.

- Medical devices for measuring blood pressure, pulse, etc., treatment units such as coronary pacemakers and heat treatment units, and devices such as artificial organs and artificial limb systems which augment physiological functions.

- Electrical instruments, equipment or systems used in disaster or crime prevention.

■ Semiconductors, by nature, may fail or malfunction in spite of our devotion to improve product quality and reliability. We urge you to take every possible precaution against physical injuries, fire or other damages which may cause failure of our semiconductor products by taking appropriate measures, including a reasonable safety margin, malfunction preventive practices and fire-proofing when designing your products.

■ This application manual is effective from Dec. 2001. Note that the contents are subject to change or discontinuation without notice. When placing orders, please confirm specifications and delivery condition in writing.

■ TOKO is not responsible for any problems nor for any infringement of third party patents or any other intellectual property rights that may arise from the use or method of use of the products listed in this application manual. Moreover, this application manual does not signify that TOKO agrees implicitly or explicitly to license any patent rights or other intellectual property rights which it holds.

■ None of ozone depleting substances(ODS) under the Montreal Protocol is used in manufacturing process of us.

**17. OFFICES**

If you need more information on this product and other TOKO products, please contact us.

■ TOKO Inc. Headquarters  
 1-17, Higashi-yukigaya 2-chome, Ohta-ku, Tokyo,  
 145-8585, Japan  
 TEL: +81.3.3727.1161  
 FAX: +81.3.3727.1176 or +81.3.3727.1169  
 Web site: <http://www.toko.co.jp/>

■ TOKO America  
 Web site: <http://www.toko.com/>

■ TOKO Europe  
 Web site: <http://www.tokoeurope.com/>

■ TOKO Hong Kong  
 Web site: <http://www.toko.com.hk/>

■ TOKO Taiwan  
 Web site: <http://www.toko.com.tw/>

■ TOKO Singapore  
 Web site: <http://www.toko.com.sg/>

■ TOKO Seoul  
 Web site: <http://www.toko.co.kr/>

■ TOKO Manila  
 Web site: <http://www.toko.com.ph/>

■ TOKO Brazil  
 Web site: <http://www.toko.com.br/>



TO BUILD THE QUALITY RELIED BY COSTOMERS  
**Semiconductor Division**

YOUR DISTRIBUTOR