2SC2736

Silicon NPN Epitaxial

HITACHI

Application

- UHF/VHF frequency converter
- Local oscillator

Outline

MPAK

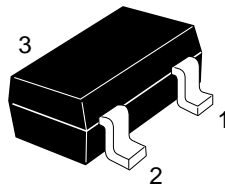

1. Emitter
2. Base
3. Collector

Absolute Maximum Ratings (Ta = 25°C)

Item	Symbol	Ratings	Unit
Collector to base voltage	V_{CBO}	30	V
Collector to emitter voltage	V_{CEO}	20	V
Emitter to base voltage	V_{EBO}	3	V
Collector current	I_C	50	mA
Collector power dissipation	P_C	150	mW
Junction temperature	T_j	150	°C
Storage temperature	T_{stg}	-55 to +150	°C

Electrical Characteristics (Ta = 25°C)

Item	Symbol	Min	Typ	Max	Unit	Test conditions
Collector to base breakdown voltage	$V_{(BR)CBO}$	30	—	—	V	$I_C = 10 \mu A, I_E = 0$
Collector to emitter breakdown voltage	$V_{(BR)CEO}$	20	—	—	V	$I_C = 1 \text{ mA}, R_{BE} = \infty$
Emitter to base breakdown voltage	$V_{(BR)EBO}$	3	—	—	V	$I_E = 10 \mu A, I_C = 0$
Collector cutoff current	I_{CBO}	—	—	500	nA	$V_{CB} = 15 \text{ V}, I_C = 0$
Collector to emitter saturation voltage	$V_{CE(sat)}$	—	—	0.7	V	$I_C = 10 \text{ mA}, I_B = 5 \text{ mA}$
DC current transfer ratio	h_{FE}	30	—	200		$V_{CE} = 10 \text{ V}, I_C = 5 \text{ mA}$
Collector output capacitance	C_{ob}	—	—	1.0	pF	$V_{CB} = 10 \text{ V}, I_E = 0, f = 1 \text{ MHz}$
Gain bandwidth product	f_T	1400	2200	—	MHz	$V_{CE} = 10 \text{ V}, I_C = 5 \text{ mA}$
Conversion gain	CG_1	—	22.5	—	dB	$V_{CC} = 12 \text{ V}, I_C = 2 \text{ mA},$ $f = 200 \text{ MHz},$ $f_{OSC} = 230 \text{ MHz (0dBm)}$
	CG_2	—	10	—	dB	$V_{CC} = 12 \text{ V}, I_C = 2 \text{ mA},$ $f = 900 \text{ MHz},$ $f_{OSC} = 930 \text{ MHz (0dBm)},$ $f_{Out} = 30 \text{ MHz}$
Noise figure	NF	—	4.0	—	dB	$V_{CC} = 12 \text{ V}, I_C = 2 \text{ mA},$ $f = 200 \text{ MHz},$ $f_{OSC} = 230 \text{ MHz (0dBm)}$
Oscillating output voltage	V_{OSC1}	—	300	—	mV	$V_{CC} = 12 \text{ V}, I_C = 7 \text{ mA},$ $f_{OSC} = 300 \text{ MHz}$
	V_{OSC2}	—	200	—	mV	$V_{CC} = 12 \text{ V}, I_C = 7 \text{ mA},$ $f_{OSC} = 930 \text{ MHz}$

Note: Marking is "TC".

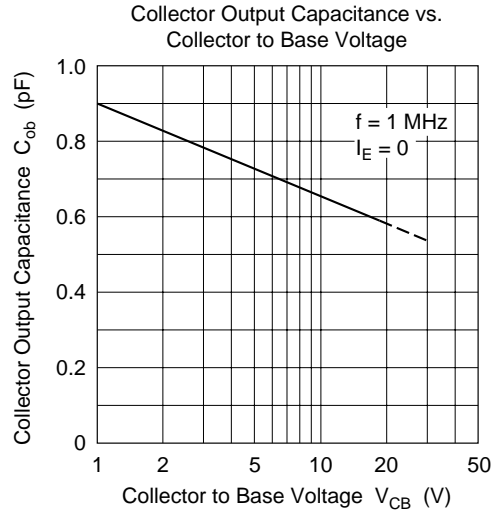
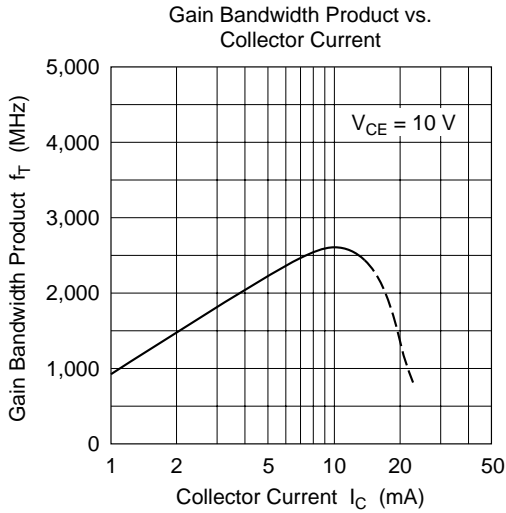
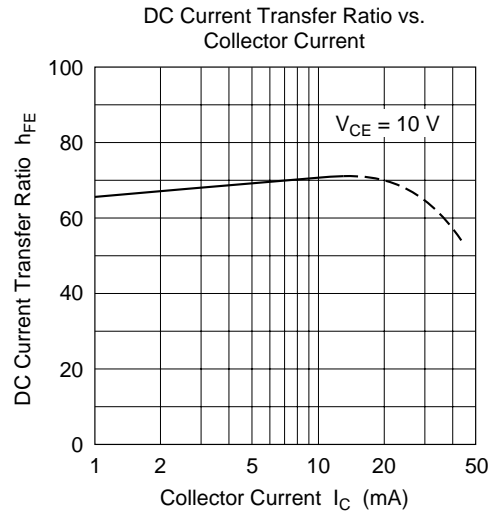
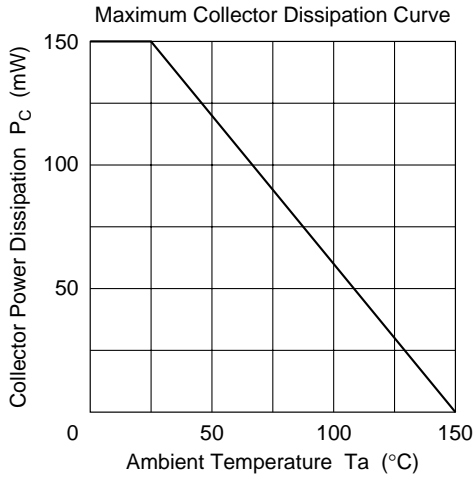

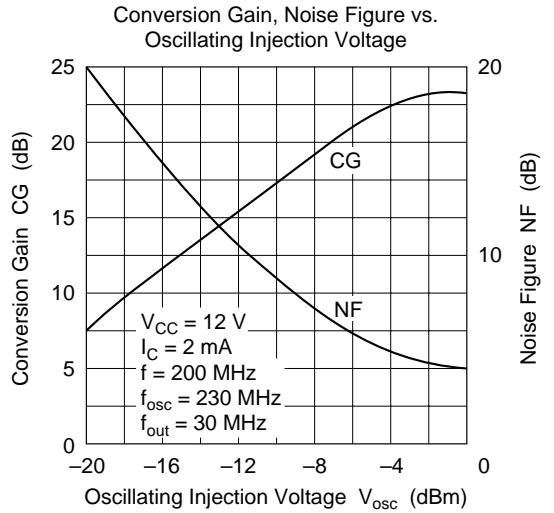
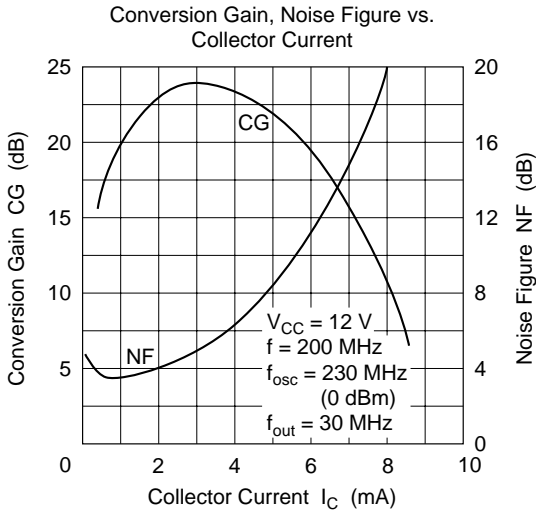
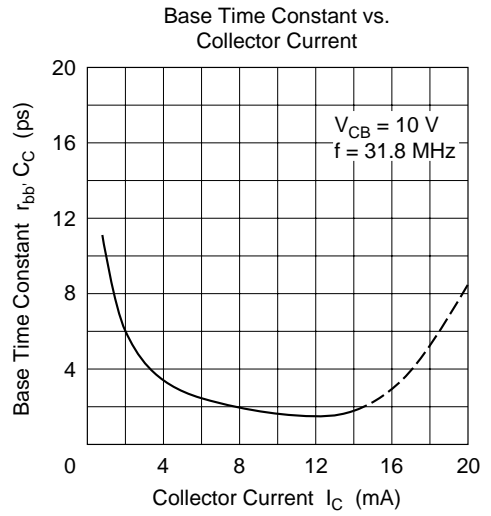
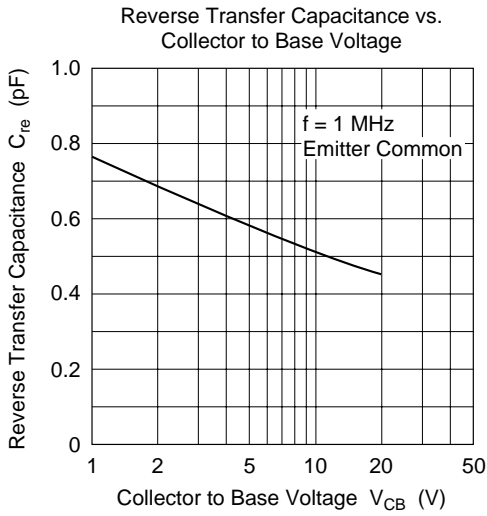

Conversion Gain vs. Collector Current

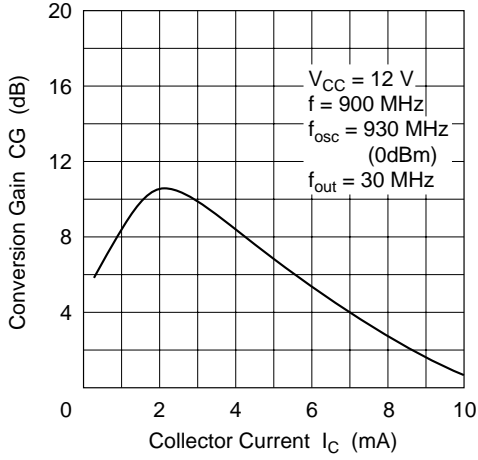

Oscillating Output Voltage vs. Collector Current

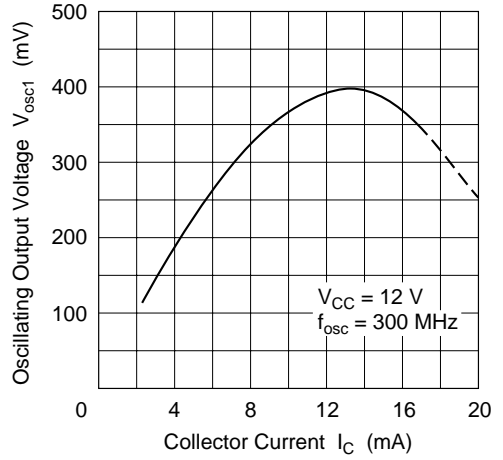

Oscillating Output Voltage vs. Collector Current

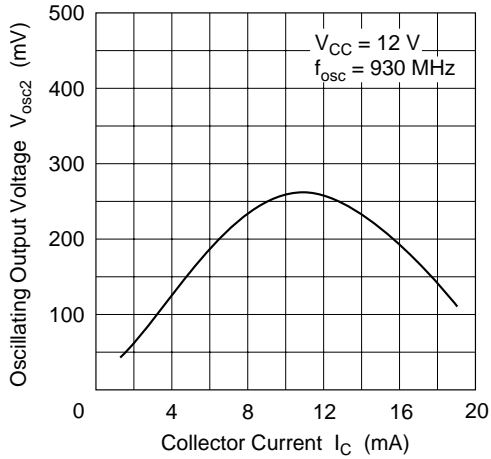

Oscillating Output Voltage vs. Supply Voltage

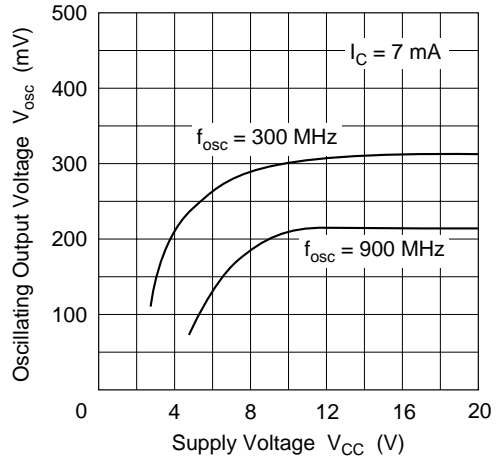

VHF Conversion Gain (CG_1) : Noise Figure Test Circuit

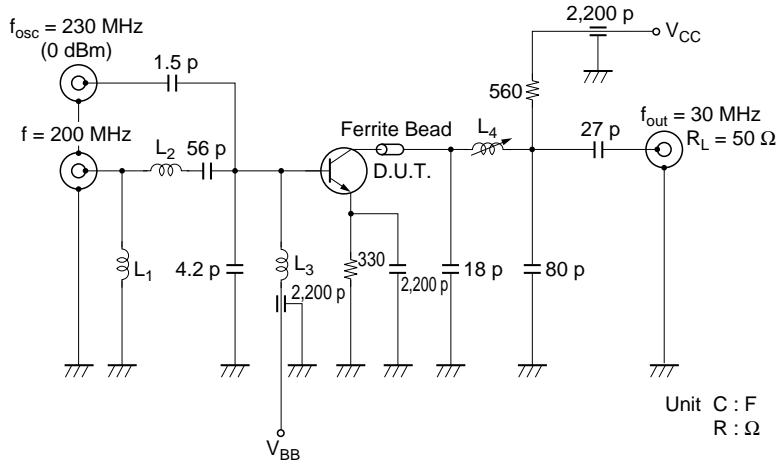

L_1 : $\phi 0.5 \text{ mm}$ Enameled Copper Wire
 4 Turns inside dia $\phi 5 \text{ mm}$

L_2 : $\phi 0.5 \text{ mm}$ Enameled Copper Wire
 4 Turns inside dia $\phi 4 \text{ mm}$

L_3 : $\phi 0.2 \text{ mm}$ Enameled Copper Wire
 6 Turns inside dia $\phi 3 \text{ mm}$

L_4 : Outside dia $\phi 5 \text{ mm}$ Bobbin,
 $\phi 0.2 \text{ mm}$ Enameled Copper Wire
 16 Turns Using Ferrite bead.

UHF Conversion Gain (CG₂) Test Circuit

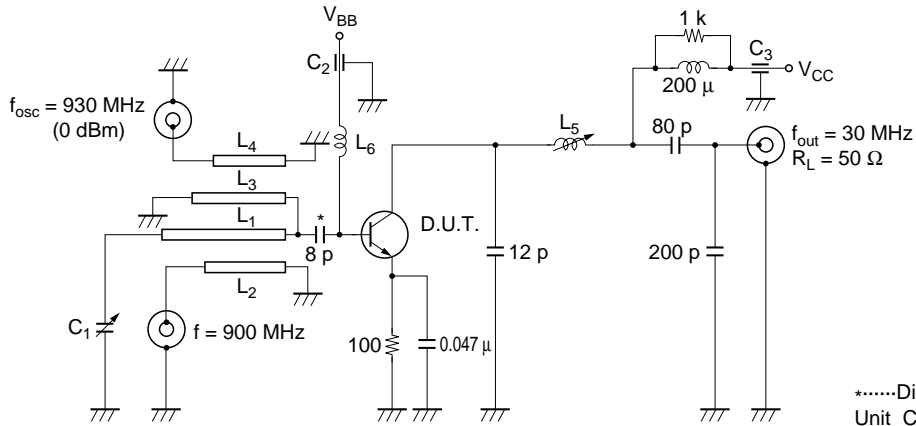

*.....Disk Capacitor
 Unit C : F
 R : Ω
 L : H

L₁ : φ1 mm Enameled Copper Wire

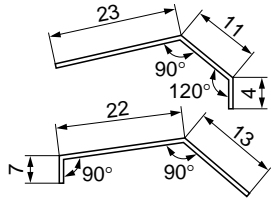

L₂ : φ1 mm Enameled Copper Wire

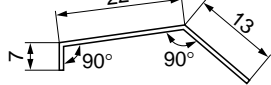

L₃ : φ1 mm Enameled Copper Wire

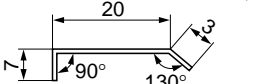

L₄ : φ1 mm Enameled Copper Wire

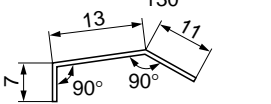

L₅ : Bobbin φ5 mm inside dia, φ0.2 mm Enameled Copper Wire 20 Turns

L₆ : φ0.5 mm Enameled Copper Wire 1 Turn inside dia φ6 mm

C₁ : 20 pF max Air Trimmer Condenser

C₂, C₃ : 1000 pF Air Core Capacitor

VHF Oscillating Output Voltage (V_{osc1}) Test Circuit

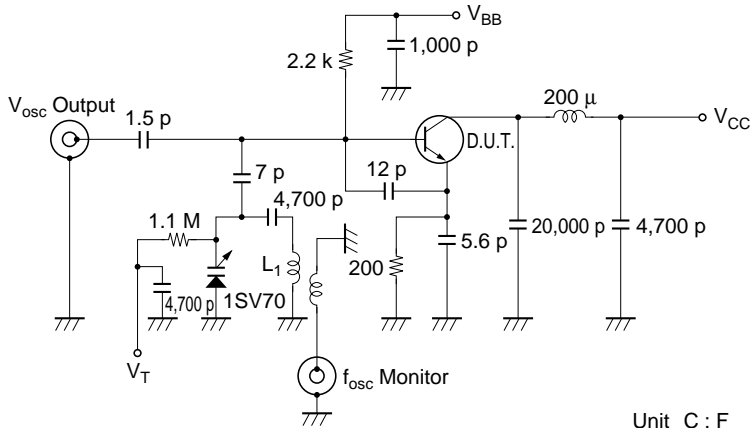

L_1 : $\phi 0.3$ mm Enameled Copper Wire
3 Turns inside dia $\phi 3$ mm

Test Frequency
 $f_{osc} = 300$ MHz

Unit C : F
R : Ω
L : H

UHF Oscillating Output Voltage (V_{osc2}) Test Circuit

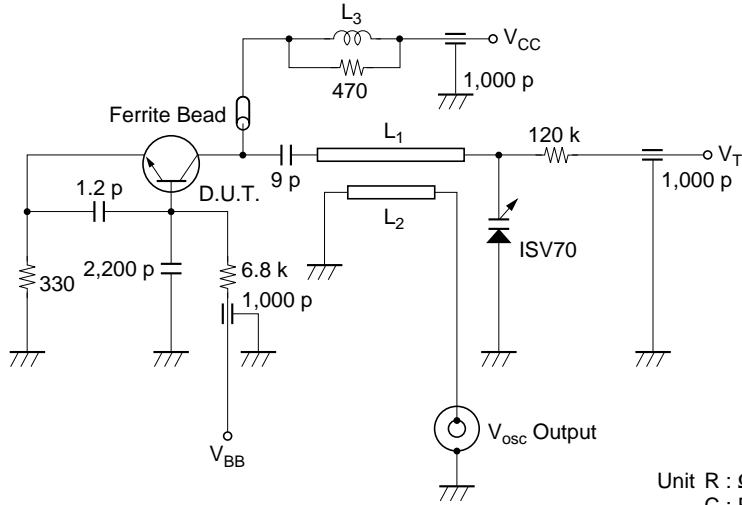

Unit R : Ω
C : F

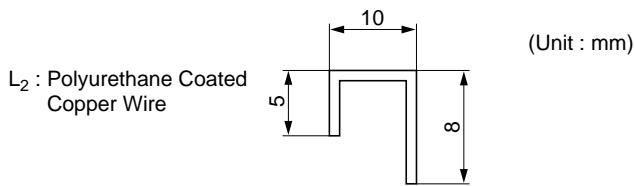
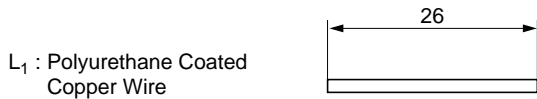

L_3 : $\phi 0.3$ mm Enameled Copper wire, 10 Turns with 470 Ω (1/4W) Resistor.

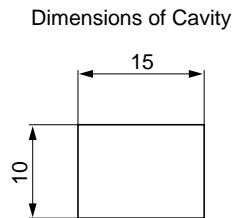

Test Frequency
 $f_{osc} = 930$ MHz

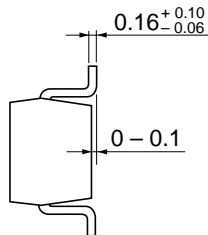
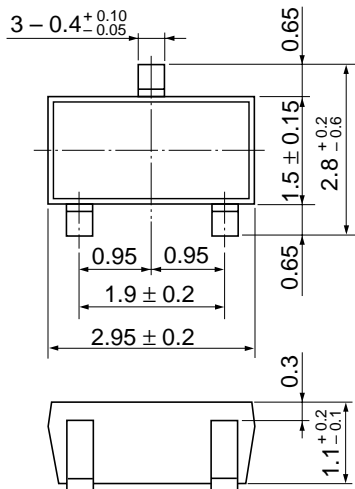

Hitachi Code	MPAK
JEDEC	—
EIAJ	Conforms
Weight (reference value)	0.011 g

Cautions

1. Hitachi neither warrants nor grants licenses of any rights of Hitachi's or any third party's patent, copyright, trademark, or other intellectual property rights for information contained in this document. Hitachi bears no responsibility for problems that may arise with third party's rights, including intellectual property rights, in connection with use of the information contained in this document.
2. Products and product specifications may be subject to change without notice. Confirm that you have received the latest product standards or specifications before final design, purchase or use.
3. Hitachi makes every attempt to ensure that its products are of high quality and reliability. However, contact Hitachi's sales office before using the product in an application that demands especially high quality and reliability or where its failure or malfunction may directly threaten human life or cause risk of bodily injury, such as aerospace, aeronautics, nuclear power, combustion control, transportation, traffic, safety equipment or medical equipment for life support.
4. Design your application so that the product is used within the ranges guaranteed by Hitachi particularly for maximum rating, operating supply voltage range, heat radiation characteristics, installation conditions and other characteristics. Hitachi bears no responsibility for failure or damage when used beyond the guaranteed ranges. Even within the guaranteed ranges, consider normally foreseeable failure rates or failure modes in semiconductor devices and employ systemic measures such as fail-safes, so that the equipment incorporating Hitachi product does not cause bodily injury, fire or other consequential damage due to operation of the Hitachi product.
5. This product is not designed to be radiation resistant.
6. No one is permitted to reproduce or duplicate, in any form, the whole or part of this document without written approval from Hitachi.
7. Contact Hitachi's sales office for any questions regarding this document or Hitachi semiconductor products.

HITACHI

Hitachi, Ltd.

Semiconductor & Integrated Circuits.
Nippon Bldg., 2-6-2, Ohte-machi, Chiyoda-ku, Tokyo 100-0004, Japan
Tel: Tokyo (03) 3270-2111 Fax: (03) 3270-5109

URL North America : <http://semiconductor.hitachi.com/>
 Europe : <http://www.hitachi-eu.com/hel/ecg>
 Asia (Singapore) : <http://www.has.hitachi.com.sg/grp3/sicd/index.htm>
 Asia (Taiwan) : http://www.hitachi.com.tw/E/Product/SICD_Frame.htm
 Asia (HongKong) : <http://www.hitachi.com.hk/eng/bo/grp3/index.htm>
 Japan : <http://www.hitachi.co.jp/Sicd/indx.htm>

For further information write to:

Hitachi Semiconductor
(America) Inc.
179 East Tasman Drive,
San Jose, CA 95134
Tel: <1> (408) 433-1990
Fax: <1>(408) 433-0223

Hitachi Europe GmbH
Electronic components Group
Dornacher Straße 3
D-85622 Feldkirchen, Munich
Germany
Tel: <49> (89) 9 9180-0
Fax: <49> (89) 9 29 30 00

Hitachi Europe Ltd.
Electronic Components Group.
Whitebrook Park
Lower Cookham Road
Maidenhead
Berkshire SL6 8YA, United Kingdom
Tel: <44> (1628) 585000
Fax: <44> (1628) 778322

Hitachi Asia Pte. Ltd.
16 Collyer Quay #20-00
Hitachi Tower
Singapore 049318
Tel: 535-2100
Fax: 535-1533

Hitachi Asia Ltd.
Taipei Branch Office
3F, Hung Kuo Building, No.167,
Tun-Hwa North Road, Taipei (105)
Tel: <886> (2) 2718-3666
Fax: <886> (2) 2718-8180

Hitachi Asia (Hong Kong) Ltd.
Group III (Electronic Components)
7/F., North Tower, World Finance Centre,
Harbour City, Canton Road, Tsim Sha Tsui,
Kowloon, Hong Kong
Tel: <852> (2) 735 9218
Fax: <852> (2) 730 0281
Telex: 40815 HITEC HX

Copyright ' Hitachi, Ltd., 1999. All rights reserved. Printed in Japan.

HITACHI