

October 20, 2000

TEL:805-498-2111 FAX:805-498-3804 WEB:http://www.semtech.com

DESCRIPTION

The SC1462 is a versatile charge pump designed for use in battery operated power supply applications over the wide input range of 1.65 to 5.5 volts. A simple, low quiescent current charge pump doubler can be implemented without costly inductors or capacitors. Internal MOSFETs and control circuitry eliminate the need for costly board space and design time. The small 6 lead SOT-23 package helps minimize board space.

The SC1462 charge pump can be used for applications that require up to 80mA of output current with V_{IN} = 2.5V to 5.5V. Typical dropout voltage ($2 \cdot V_{IN} - V_{OUT}$) is shown below for several values of V_{IN} .

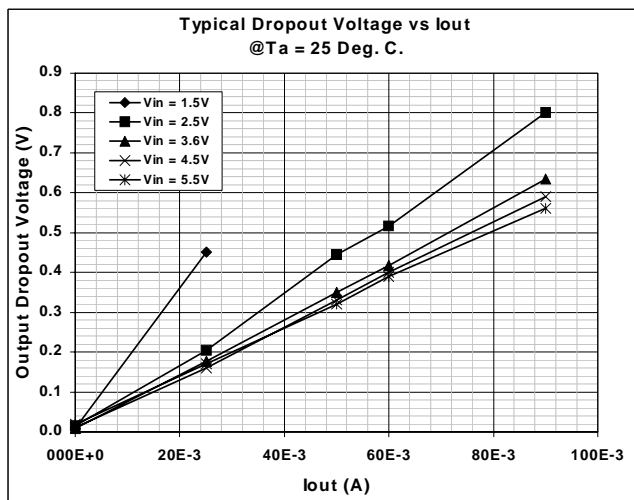

FEATURES

- Input supply voltage range of 1.65V to 5.5V
- Small size - 6 pin SOT-23 package
- Typical efficiency of :
 - 91% @ $V_{in} = 2.5V$, $I_{out} = 45mA$
 - 94% @ $V_{in} = 3.6V$, $I_{out} = 55mA$
- Short circuit and over-temperature protection
- 140 μA typical input current @ no load
- Shutdown current <1 μA
- Designed to work with ceramic or Tantalum capacitors
- Fixed frequency of 160kHz
- All specifications rated over full temperature range (-40°C to 85°C)

APPLICATIONS

- Cellular phones
- Handheld devices

ORDERING INFORMATION

DEVICE ⁽¹⁾	PACKAGE	Temp. Range (T_A)
SC1462ISKTR	SOT-23-6	-40°C to 85°C

Note:

(1) Only available in tape and reel packaging. A reel contains 3000 devices.

TYPICAL APPLICATION SCHEMATIC

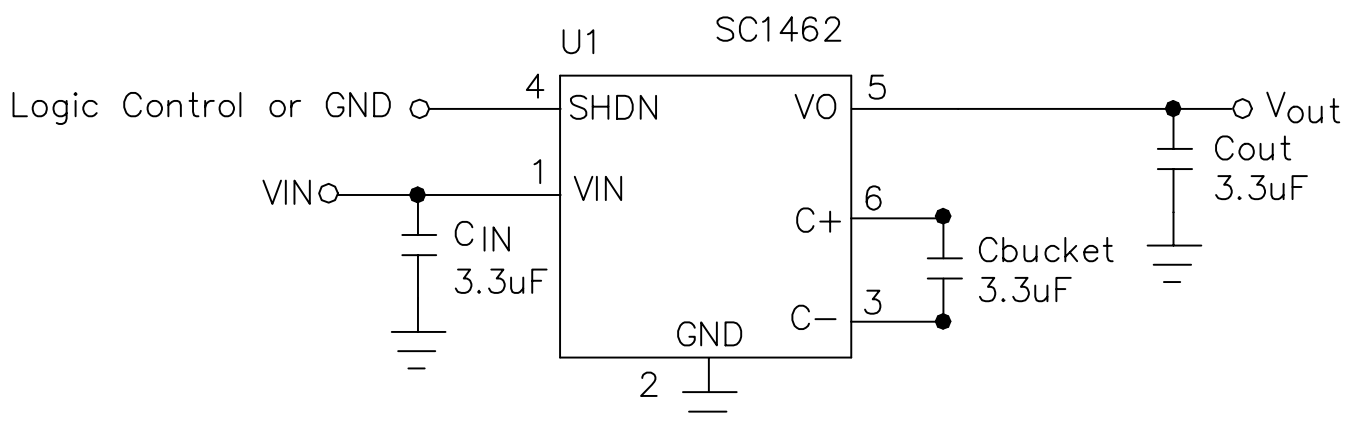

October 20, 2000

TEL:805-498-2111 FAX:805-498-3804 WEB:http://www.semtech.com

ABSOLUTE MAXIMUM RATINGS

Parameter	Symbol	Maximum	Units
Supply Voltage	V _{IN}	-0.3 to +6.0	V
Output Voltage	VO	-0.3 to +12	V
V _{OUT} Short Circuit Duration	SC	Indefinite	
Thermal Resistance Junction to Ambient	θ _{JA}	230	°C/W
Operating Ambient Temperature Range	T _A	-40 to +85	°C
Junction Temperature Range	T _J	-40 to +125	°C
Storage Temperature Range	T _{STG}	-65 to +150	°C
Lead Temperature (Soldering) 10 seconds	T _L	300	°C

ELECTRICAL CHARACTERISTICS

 Unless specified: T_A = -40°C to 85°C, SHDN = GND, 1.65V ≤ V_{IN} ≤ 5.5V, C_{IN} = C_{OUT} = C_{BUCKET} = 3.3μF (ESR = 0.3Ω).

Parameter	Symbol	Conditions	MIN	TYP	MAX	Units
Input Supply Voltage	V _{IN}		1.65		5.5	V
Input Supply Current	I _{IN}	I _O = 0, V _{IN} = 2.5V freq = 160kHz		140	260	μA
		I _O = 0, V _{IN} = 3.6V freq = 160kHz		200	400	μA
		SHDN = V _{IN}		0.1	1	μA
Output Resistance ⁽⁵⁾	R _{out}	V _{IN} = 2.5V		9.5	13.5	Ω
Output Resistance ⁽⁵⁾	R _{out}	V _{IN} = 3.6V		7.5	10.5	Ω
Total Switch Resistance ⁽⁶⁾	R _{SW}	V _{IN} = 2.5V		3	4.5	Ω
Total Switch Resistance ⁽⁶⁾	R _{SW}	V _{IN} = 3.6V		2	3	Ω
Output Current	I _O	V _{IN} = 2.5V			80	mA
		V _{IN} = 3.6V			80	mA
Oscillator Frequency	OSC	1.65V ≤ V _{IN} ≤ 5.5V	100	160	200	KHz
Short Circuit Current	I _{SC}	V _{out} = 0V		200		mA
Output Ripple (pk-pk) ⁽¹⁾⁽³⁾	V _R	I _O = 45mA, V _{IN} = 2.5V Frequency = 160kHz		75		mV
Power Efficiency ⁽¹⁾	η	I _O = 45mA, V _{IN} = 2.5V freq = 160kHz	86			%

October 20, 2000

TEL:805-498-2111 FAX:805-498-3804 WEB:http://www.semtech.com

ELECTRICAL CHARACTERISTICS

 Unless specified: $T_A = -40^{\circ}\text{C}$ to 85°C , SHDN = GND, $1.65\text{V} \leq V_{\text{IN}} \leq 5.5\text{V}$, $C_{\text{IN}} = C_{\text{OUT}} = C_{\text{BUCKET}} = 3.3\mu\text{F}$ (ESR = 0.3Ω).

Parameter	Symbol	Conditions	MIN	TYP	MAX	Units
Maximum Output Voltage ⁽³⁾	V_{OUT}	$I_{\text{O}} = 0\text{mA}$			$2 \cdot V_{\text{IN}}$	V
Input High Threshold	V_{ih}	SHDN pin, $2.5 \leq V_{\text{IN}} \leq 5.5$	1.6			V
Input Low Threshold	V_{il}	SHDN pin, $2.5 \leq V_{\text{IN}} \leq 5.5$			0.4	V
Time to Regulation at Turn-on ⁽²⁾	t_{ON}	$I_{\text{O}} = 0$ to 60mA , $V_{\text{IN}} = 3.6\text{V}$ freq = 160kHz		500		μs
Over Temperature protection ⁽³⁾	O.T.			140		$^{\circ}\text{C}$
Over Temperature Hysteresis ⁽³⁾	O.T.H			20		$^{\circ}\text{C}$

NOTES:

- (1) All electrical characteristics are for the application circuit on page 1.
- (2) Soft start functionality is performed along with short circuit protection. If V_{OUT} is less than $V_{\text{IN}} - 200\text{mV}$, then all switches are turned off and V_{OUT} is charged with a 200mA current source from V_{IN} . When V_{OUT} reaches $V_{\text{IN}} - 200\text{mV}$ all switches are enabled.
- (3) Guaranteed by design.
- (4) This device is ESD sensitive. Use of standard ESD handling precautions is required.
- (5) The internal switch resistance, the capacitor ESR and the Oscillator's switching frequency all contribute to R_{out} . See the CAPACITOR SELECTION section for information on applying the R_{out} specification.
- (6) The parameter R_{sw} is equal to the total resistance of all 4 internal switches. See the CAPACITOR SELECTION section for information on applying the R_{sw} specification. This parameter was calculated from actual output resistance and the equation on page 7 for R_{out} .

October 20, 2000

TEL:805-498-2111 FAX:805-498-3804 WEB:http://www.semtech.com

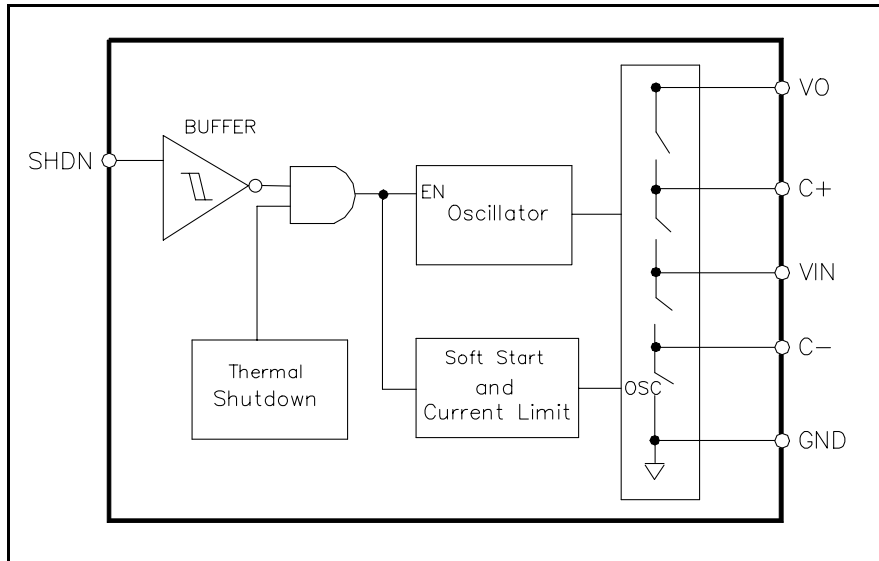
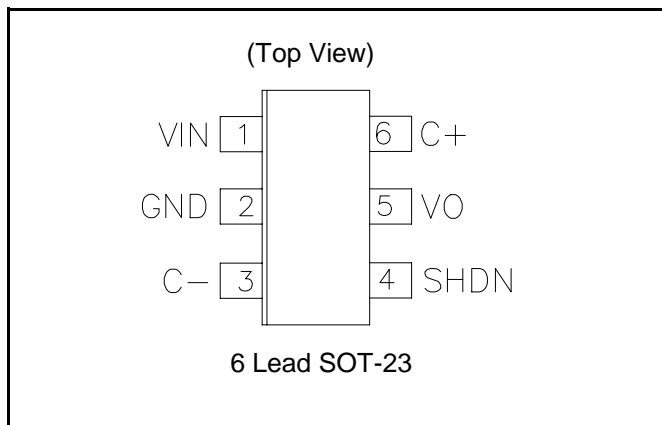
BLOCK DIAGRAM

PIN CONFIGURATION

PIN DESCRIPTION

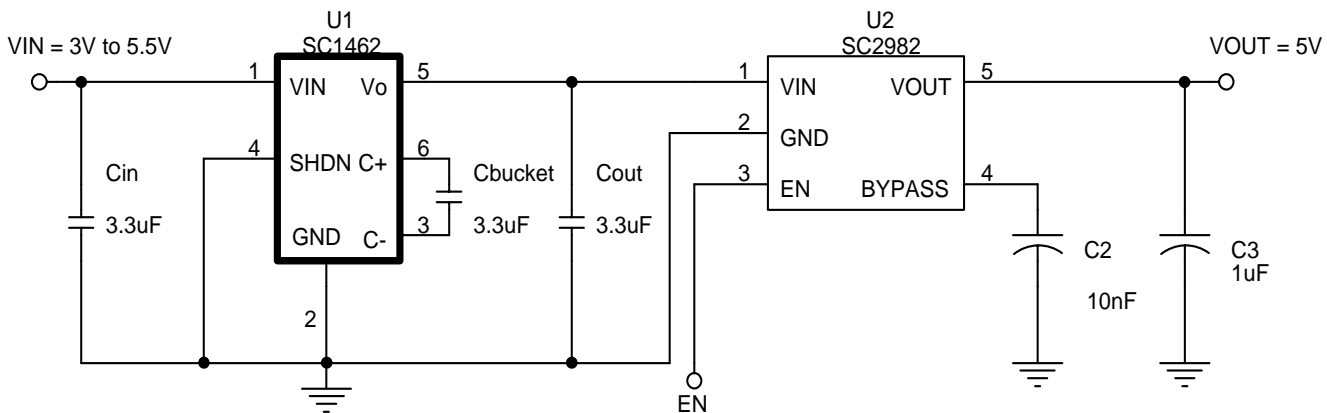
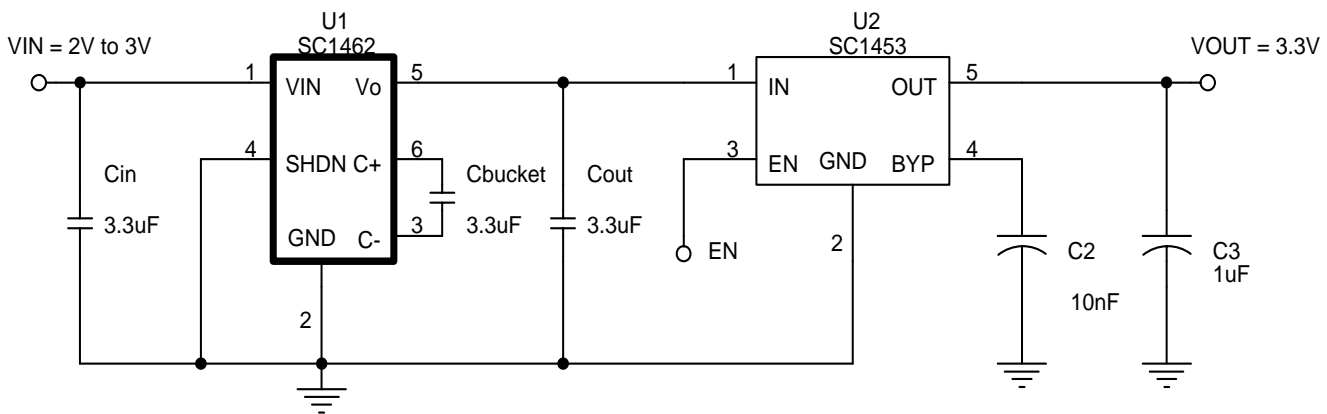
Pin # SOT-23-6	Pin Name	Pin Function
1	VIN	Supply voltage input.
2	GND	Ground.
3	C-	This pin should be connected to the negative terminal of the external charging capacitor.
4	SHDN	Shutdown pin. When this pin is connected to VIN, the device enters sleep mode.
5	VO	Voltage output.
6	C+	This pin should be connected to the positive terminal of the external charging capacitor.

October 20, 2000

 TEL:805-498-2111 FAX:805-498-3804 WEB:<http://www.semtech.com>
5 Volts Fixed output Voltage

3.3 Volts Fixed output Voltage

October 20, 2000

TEL:805-498-2111 FAX:805-498-3804 WEB:http://www.semtech.com

THEORY OF OPERATION

The SC1462 utilizes a switched capacitor charge pump, to generate an output voltage approximately $2 \times V_{in}$.

An internal oscillator generates two out of phase fixed frequency clock signals which turn on and off internal MOSFET switches. During phase1 of clock, the flying charge pump capacitor is charged to V_{in} through switches S1, and S2. During phase2 the flying charge pump capacitor is connected in series with the input voltage via S3, and S4, producing an output voltage.

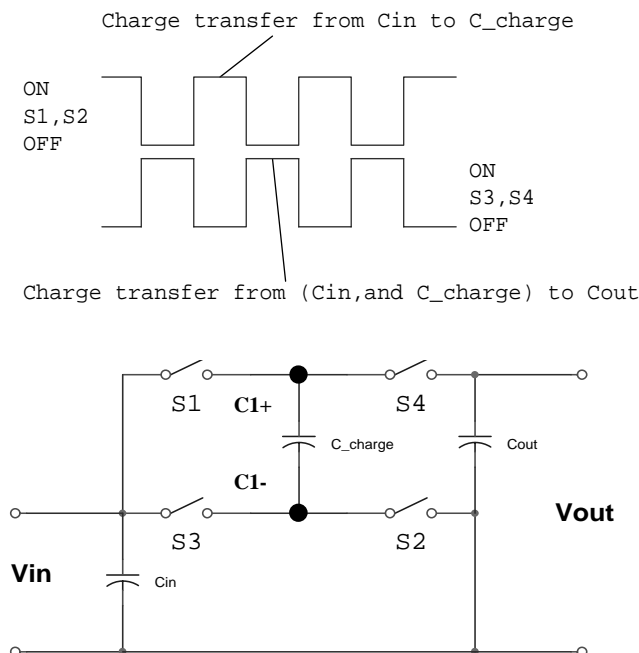

SHORT CIRCUIT / SOFT START

An internal current limit and soft start circuit provides protection against output short circuit and limits large current spikes generated during the initial start up to charge output capacitor.

If V_{OUT} is less than $V_{IN} - 200mV$, then all switches are turned off and V_{OUT} is charged with a 200mA current source from V_{IN} . When V_{OUT} reaches $V_{IN} - 200mV$, the current source is disconnected from output and the charge pump circuitry is enabled again.

OUTPUT CURRENT

The dropout voltage for a charge pump doubler is defined as $2 * V_{in} - V_{out}$. The maximum output current is usually specified as that which will not cause the dropout voltage to exceed the requirements of the application. The calculation of the dropout voltage is given in the capacitor selection section on page 7. Typical dropout voltages versus I_{out} are graphed on page 8.

THERMAL SHUTDOWN

The thermal shutdown circuit provides added protection to the SC1462. During a V_{OUT} short circuit condition or if the load is excessive, the over temperature circuitry will shut down the charge pump if the junction temperature exceeds approximately 140°C. The charge pump is enabled only if the junction temperature drops to approximately 120°C. The SC1462 will cycle in and out of thermal shut down until the short circuit or the excessive load condition on V_{out} is removed, thereby improving device reliability. The junction temperature can be calculated from the following formula if the ambient temperature (T_a) and the charge pump power dissipation (P_{diss}) are known.

$$T_J = T_a + P_{diss} * \theta_{JA} \quad ; \quad \theta_{JA} = 230 \text{ } ^\circ\text{C/W}$$

October 20, 2000

TEL:805-498-2111 FAX:805-498-3804 WEB:http://www.semtech.com

CAPACITOR SELECTION

Capacitor selection is based on both the maximum acceptable ripple voltage and the maximum tolerable drop at the output.

Ripple

The peak to peak output ripple voltage is dependent on the following factors:

- 1- Oscillator Frequency
- 2- ESR of C_{OUT}
- 3- Capacitance value of C_{out}

Item 1 is fixed and depend on the charge pump device used. Item 2, and 3 can be optimized for best performance and reduction of the output ripple.

The following formula could be used for an approximation for V_{out_ripple} .

$$V_{out_ripple} = \frac{I_{out}}{2 \times F_{osc} \times C_{out}} + 2 \times I_{out} \times ESR_{C_{out}}$$

Vout Drop

The voltage drop at the output is specified with the following equation:

$$V_{out_drop} = I_{out} \times R_{out}$$

R_{out} is dependent on the following factors:

- 1- Oscillator Frequency
- 2- ESR of C_{OUT} & C_{bucket}
- 3- Capacitance value of C_{OUT} & C_{bucket}
- 4- Internal switch resistance (R_{sw} = Total of all 4 switch resistances).

A good approximation for calculating the output resistance is shown below.

$$R_{out} \cong \frac{1}{F_{osc} \times C_{bucket}} + 2 \times R_{SW} + 4 \times ESR_{C_{bucket}} + ESR_{C_{out}}$$

This equation can be used to calculate C_{bucket} for a specific V_{out} when V_{in} and I_{out} are known. The maximum value for the R_{sw} from the Electrical Characteristics section on page 2 should be used in order to find a worst case number.

LAYOUT CONSIDERATION

Standard power board layout should followed to ensure proper operation. Any stray inductance should be minimized, this can be achieved by using large power planes or traces, and reducing the distances between input, output and the load. All components should be placed as close as possible to the SC1462.

Following tables show typical capacitor characteristics, and capacitor manufactures.

Component	ESR (Ohms)	ESL (nH)
0.1 uF Ceramic 0603 package	0.050	1.60
1.0 uF Ceramic 1206 package	0.040	0.47
10 uF Ceramic 1206 package	0.075	0.5
47 uF, 16V Tantalum D case	0.100	0.60
330 uF, 6.3V "OSCON"	0.025	2.5
330 uF, 16V Al Electrolytic	0.143	2.37
820 uF, 4.0V "OSCON"	0.012	2.5
1000 uF, 10V Al Electrolytic	0.053	5

Capacitor Manufacturers	Phone
AVX Corp.	(803)-448-9411
VISHAY	(207)-324-4140
Nichicon Corp.	(708)-843-7500
muRata	(800)-831-9172
TOKIN	(408)-432-8020
Taiyo Yuden	(800)-348-2496
Sanyo	(619)-661-6835

October 20, 2000

TEL:805-498-2111 FAX:805-498-3804 WEB:http://www.semtech.com

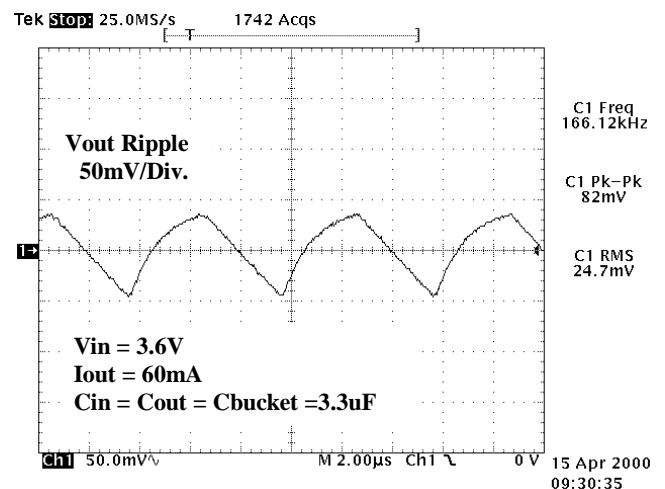
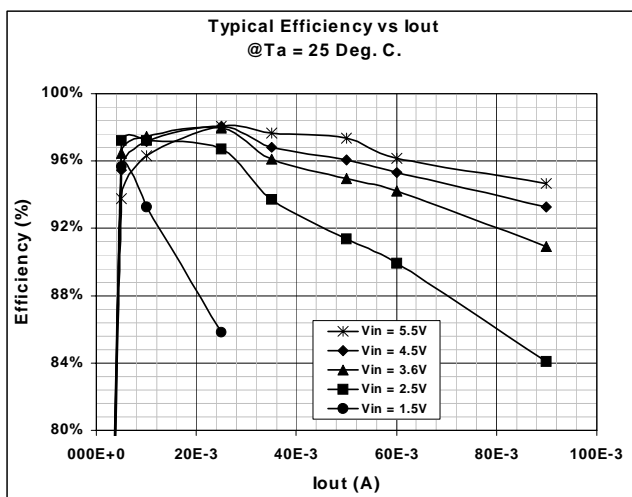
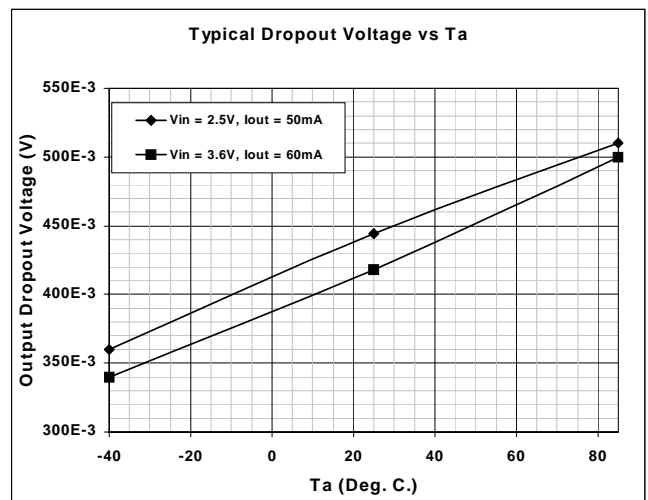
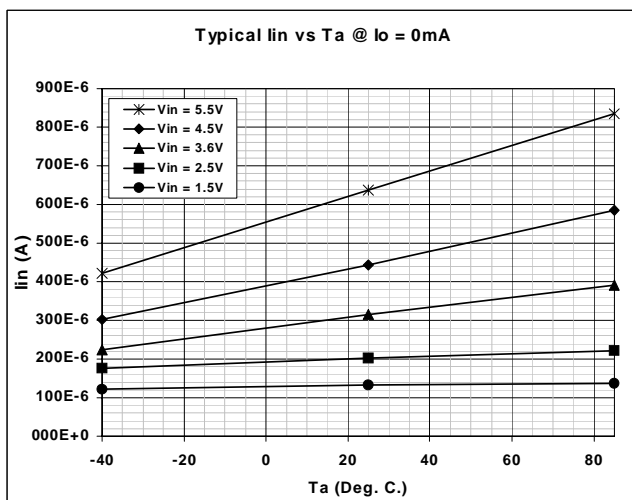
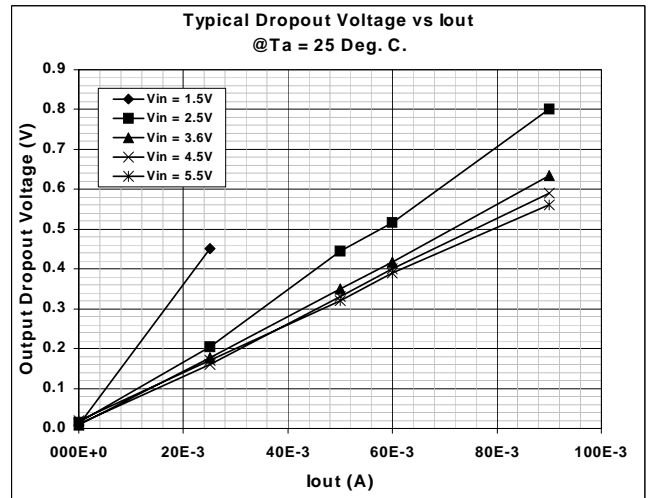
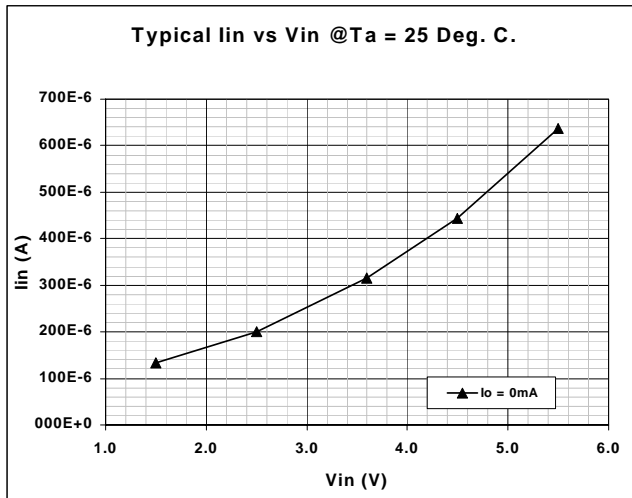

October 20, 2000

TEL:805-498-2111 FAX:805-498-3804 WEB:http://www.semtech.com

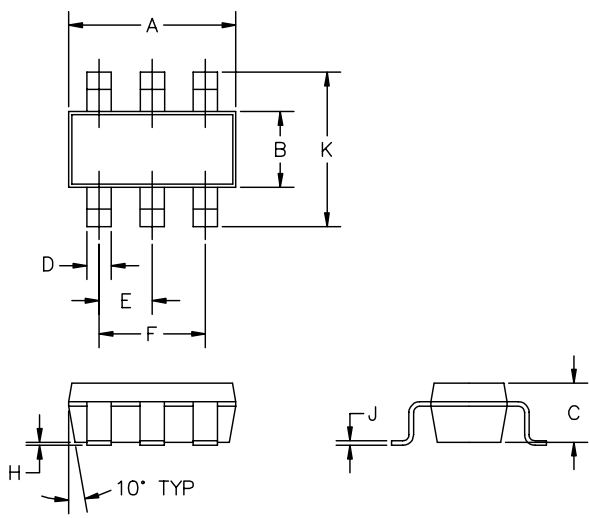
DEVICE OUTLINE - SOT23-6L

DIM ^N	INCHES		MM		NOTE
	MIN	MAX	MIN	MAX	
A	.110	.120	2.80	3.05	—
B	.059	.070	1.50	1.75	—
C	.036	.051	.90	1.30	—
D	.014	.020	.35	.50	—
E	.033	.040	.85	1.05	—
F	.067	.083	1.7	2.1	—
H	.0004	.006	.010	.150	—
J	.0035	.008	.090	.20	—
K	.102	.118	2.6	3.00	—

② PACKAGE OUTLINE EXCLUSIVE OF MOLD FLASH AND METAL BURR.
 ① CONTROLLING DIMENSIONS: MILLIMETERS.

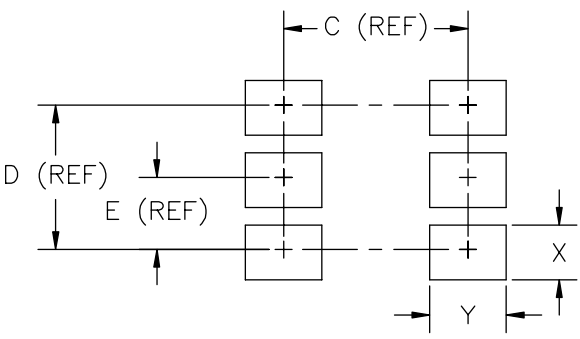
MINIMUM LAND PATTERN - SOT23-6L

DIM ^N	INCHES	MM	NOTE
C	.094	2.4	—
D	.074	1.9	—
E	.037	.95	—
X	.028	.7	—
Y	.039	1.0	—

ECN00-1344