

FEATURES

- Wide Frequency Band: 0.8 to 3GHz
- Medium Power: P1dB=26dBm (Typ.)@f=0.8 - 3GHz
- High Linear Gain: GL=19dB (Typ.)@ f=0.8 - 3GHz
- Wide Operating Temperature Range
- Hermetically Sealed Package

DESCRIPTION

The FMM5027VJ is a MMIC power amplifier that includes three amplifier stages designed for applications in the 0.8 to 3.0GHz frequency range. This product is uniquely suited for use in cellular, PCS/PCN, WLL base station amplifiers as it offers high gain, long term reliability and ease of use.

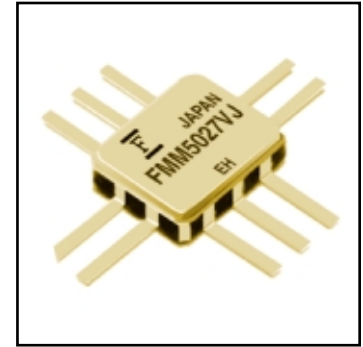

Fujitsu's stringent Quality Assurance Program assures the highest reliability and consistent performance.

ABSOLUTE MAXIMUM RATINGS (Ambient Temperature Ta=25°C)

Item	Symbol	Rating	Unit
DC Input Voltage	V _{DD1, 2}	10	V
DC Input Voltage	V _{GG1, 2}	-8	V
Input Power	P _{in}	15	dBm
Storage Temperature	T _{stg}	-55 to +150	°C
Operating Case Temperature	T _{op}	-40 to +85	°C

ELECTRICAL CHARACTERISTICS (Case Temperature Tc=25°C)

Item	Symbol	Test Conditions	Limit			Unit
			Min.	Typ.	Max.	
Frequency Range	f		0.8 - 3.0			GHz
Output Power at 1dB G.C.P.	P1dB	V _{DD1, 2} = 8V V _{GG1, 2} = -3V P _{in} = -5dBm	25.0	26.0	-	dBm
Linear Gain	GL		17.0	19.0	-	dB
Gain Flatness	ΔG		-	2.0	3.0	dB
Input VSWR	VSWR _i		-	2:1	-	-
DC Input Current	I _{DD}	V _{DD1, 2} = 8V V _{GG1, 2} = -3V	-	220	300	mA
DC Input Current	I _{GG}		-	2	4	mA

CASE STYLE: VJ

G.C.P.: Gain Compression Point

FMM5027VJ

MMIC Power Amplifier

OUTPUT POWER vs. FREQUENCY

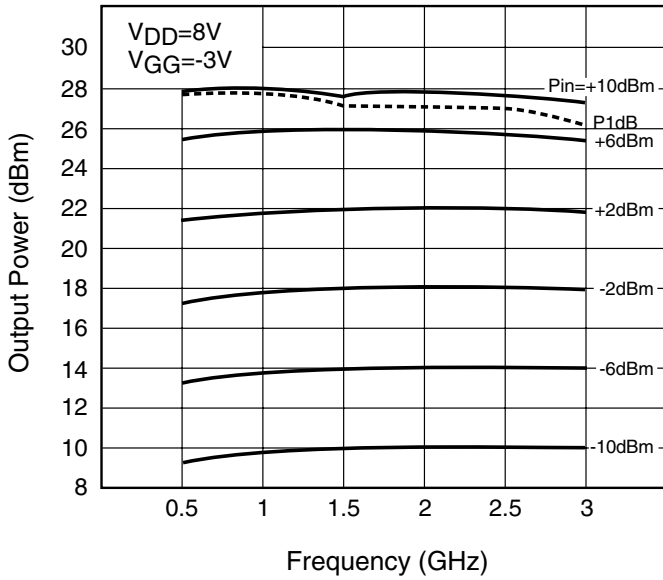

OUTPUT POWER vs. INPUT POWER

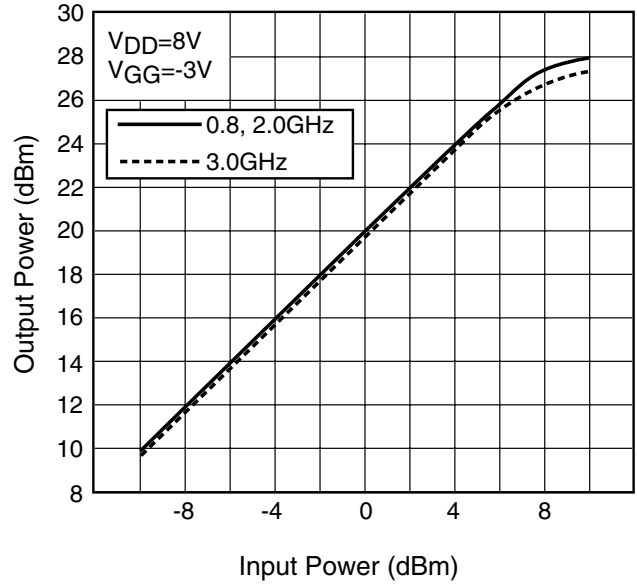

OUTPUT POWER vs. IMD

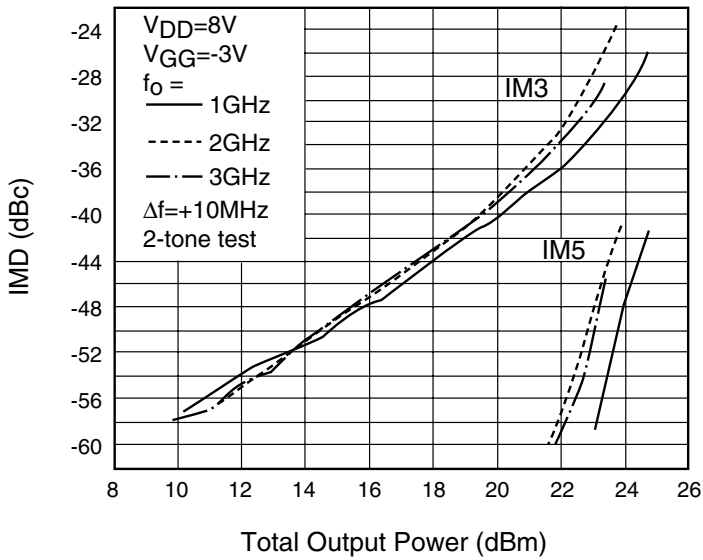

RECOMMENDED TEST CIRCUIT

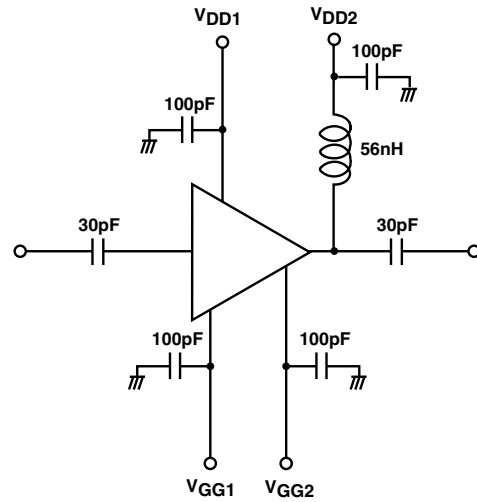

FMM5027VJ

MMIC Power Amplifier

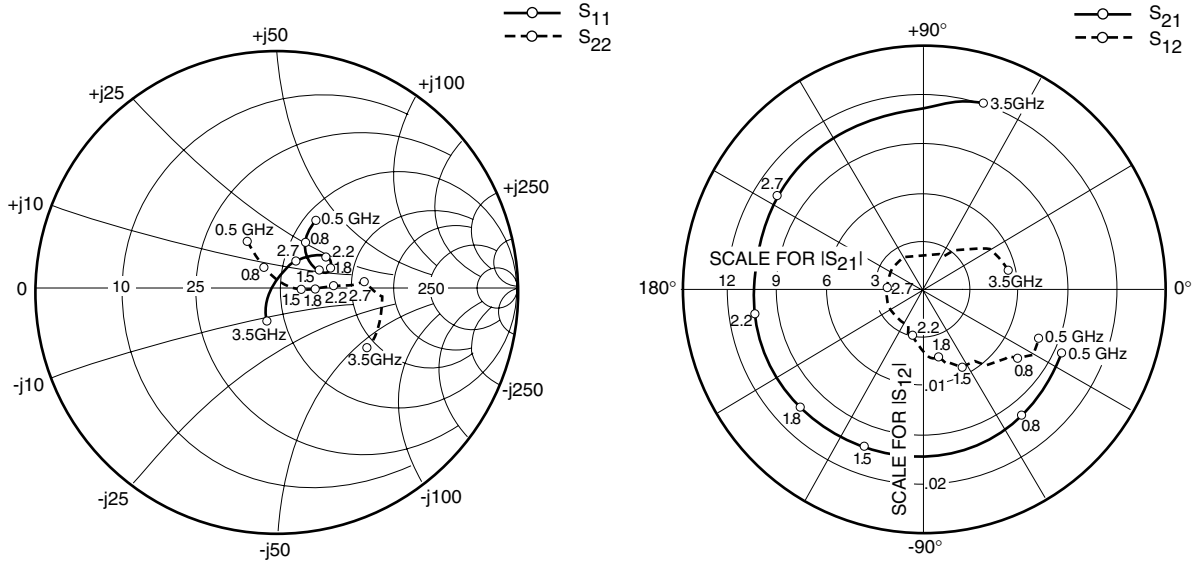

S-PARAMETERS

$V_{DS} = 8V, V_{GG} = -3V$

FREQUENCY (MHZ)	S11		S21		S12		S22	
	MAG	ANG	MAG	ANG	MAG	ANG	MAG	ANG
500	.148	-103.6	9.376	-24.8	.013	-23.5	.226	122.4
600	.101	-114.3	9.563	-34.3	.013	-28.3	.171	121.0
700	.063	-126.9	9.702	-43.3	.013	-30.9	.131	119.5
800	.032	-161.2	9.857	-52.1	.012	-36.8	.099	117.3
900	.023	116.7	9.932	-61.0	.011	-38.2	.071	113.9
1000	.048	85.6	10.088	-69.5	.011	-40.1	.050	105.8
1100	.078	72.7	10.152	-77.9	.011	-40.4	.032	84.2
1200	.104	61.6	10.211	-86.4	.010	-50.9	.033	41.5
1300	.137	55.7	10.338	-94.7	.009	-55.7	.040	14.4
1400	.164	51.1	10.363	-103.3	.009	-54.4	.055	2.1
1500	.185	46.0	10.435	-111.5	.009	-63.4	.074	-3.2
1600	.208	40.7	10.462	-120.1	.008	-71.1	.099	-4.8
1700	.229	36.2	10.538	-128.5	.008	-72.7	.114	-3.9
1800	.236	32.5	10.578	-137.2	.008	-70.6	.136	-4.5
1900	.242	29.1	10.590	-145.9	.007	-77.6	.162	-2.7
2000	.246	25.2	10.632	-154.5	.007	-85.0	.190	-1.2
2100	.243	23.0	10.620	-163.2	.006	-93.8	.208	0.4
2200	.237	20.8	10.630	-171.8	.005	-106.5	.236	1.4
2300	.229	18.7	10.549	179.3	.005	-109.2	.263	1.7
2400	.204	19.5	10.604	170.9	.004	-114.5	.285	1.9
2500	.195	23.1	10.770	165.0	.004	-131.2	.320	2.8
2600	.188	26.9	10.787	156.4	.004	-147.2	.344	4.2
2700	.178	31.3	10.788	147.8	.004	178.5	.362	4.2
2800	.171	36.2	10.709	138.3	.004	157.2	.374	1.4
2900	.179	43.6	10.693	129.1	.004	144.7	.398	-1.1
3000	.186	51.1	11.044	118.9	.004	122.5	.432	-4.7
3100	.201	55.1	11.137	111.0	.004	66.5	.433	-6.2
3200	.244	56.5	11.133	101.6	.004	59.3	.440	-10.2
3300	.261	59.2	11.222	91.1	.005	52.6	.445	-16.5
3400	.295	59.7	11.881	81.4	.008	31.8	.454	-23.4
3500	.324	60.0	12.079	72.4	.009	12.2	.447	-34.1

FMM5027VJ

MMIC Power Amplifier

Case Style VJ

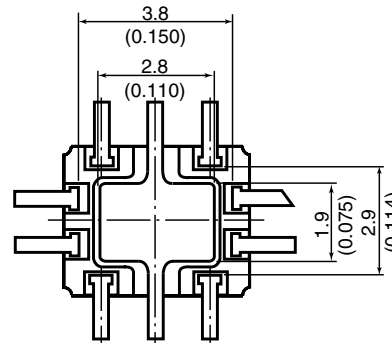
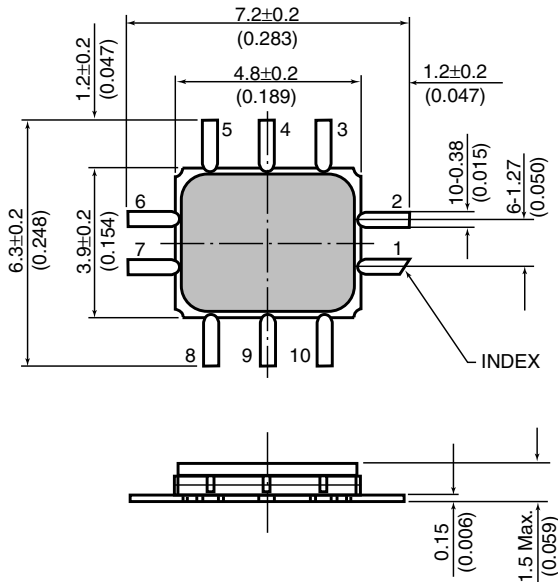

LEAD ASSIGNMENT

Lead	Symbol	Lead	Symbol
1.	RF in	6.	RF out/VDD2
2.	NC	7.	NC
3.	VGG1	8.	VDD1
4.	GND	9.	GND
5.	VGG2	10.	NC

Unit: mm(inches)

For further information please contact:

FUJITSU COMPOUND SEMICONDUCTOR, INC.
 2355 Zanker Rd.
 San Jose, CA 95131-1138, U.S.A.
 Phone: (408) 232-9500
 FAX: (408) 428-9111
 www.fcsi.fujitsu.com

FUJITSU MICROELECTRONICS EUROPE, GmbH
 Quantum Devices Division
 Network House
 Norreys Drive
 Maidenhead, Berkshire SL6 4FJ
 Phone: +44 (0)1628 504800
 FAX: +44 (0)1628 504888

CAUTION

Fujitsu Compound Semiconductor Products contain **gallium arsenide (GaAs)** which can be hazardous to the human body and the environment. For safety, observe the following procedures:

- Do not put these products into the mouth.
- Do not alter the form of this product into a gas, powder, or liquid through burning, crushing, or chemical processing as these by-products are dangerous to the human body if inhaled, ingested, or swallowed.
- Observe government laws and company regulations when discarding this product. This product must be discarded in accordance with methods specified by applicable hazardous waste procedures.

Fujitsu Limited reserves the right to change products and specifications without notice. The information does not convey any license under rights of Fujitsu Limited or others.

© 1998 FUJITSU COMPOUND SEMICONDUCTOR, INC.
 Printed in U.S.A. FCSI0598M200