

3-INPUT VIDEO SWITCH

■ GENERAL DESCRIPTION

The NJM2235 is 3-input video switch for video and audio signal. It has clamp function and so is applied to fixed DC level of video signal. Its operating supply voltage range is 5 to 12V and bandwidth is 10MHz. Crosstalk is 70dB (at 4.43MHz).

■ FEATURES

- Operating Voltage (+4.75V~+13V)
- 3 Input-1 Output
- Internal Clamp Function
- Wide Operating Supply Voltage Range 4.75~13V
- Cross-talk 70dB (at 4.43MHz)
- Wide Frequency Range 10MHz
- Muting Function available
- Package Outline DIP-8, DMP-8, SIP-8, SSOP-8
- Bipolar Technology

■ APPLICATION

- VCR: Video Camera AV-TV Video Disc Player

■ PIN CONFIGURATION

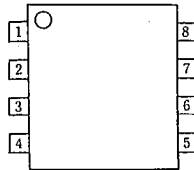

NJM2235D
NJM2235M
NJM2235V

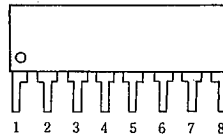

NJM2235L

PIN FUNCTION

1. V_{in1}
2. SW1
3. V_{in2}
4. SW2
5. V_{in3}
6. V^*
7. V_{out}
8. GND

■ BLOCK DIAGRAM

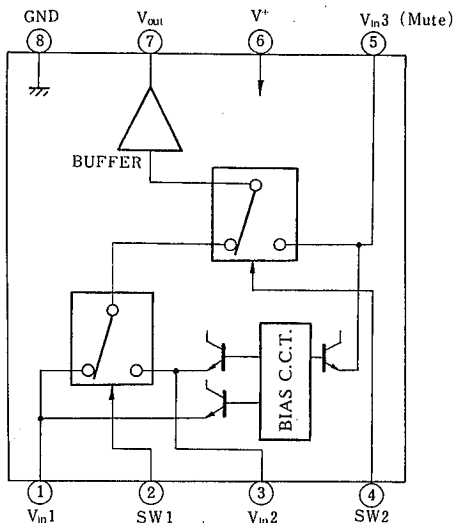

■ INPUT CONTROL SIGNAL - OUTPUT SIGNAL

SW 1	SW 2	OUTPUT SIGNAL
L	L	V_{in1}
H	L	V_{in2}
L/H	H	V_{in3}

■ ABSOLUTE MAXIMUM RATINGS

(Ta=25°C)

PARAMETER	SYMBOL	RATINGS	UNIT
Supply Voltage	V*	15	V
Power Dissipation	Pd	(DIP8) 500	mW
		(DMP8) 300	mW
		(SSOP8) 250	mW
		(SIP8) 800	mW
Operating Temperature Range	Topr	-20~+75	°C
Storage Temperature Range	Tstg	-40~+125	°C

■ ELECTRICAL CHARACTERISTICS

(V*=5V, Ta=25°C)

PARAMETER	SYMBOL	TEST CONDITION	MIN.	TYP.	MAX.	UNIT
Recommended Supply Voltage	V*		4.75	—	13.0	V
Operating Current	Icc	S1=S2=S3=S4=S5=1	—	10.5	14.0	mA
Frequency Characteristics	Grz	Vi=2.0Vpp Vo(10Hz)/Vo(100kHz)	-1.0	—	+1.0	dB
Voltage Gain	Gv	Vi=2.5Vpp, 100kHz Vo/Vi	-0.5	—	+0.5	dB
Differential Gain	DG	Vi=2Vpp Staircase signal	—	0	—	%
Differential Phase	DP	Vi=2Vpp Staircase signal	—	0	—	deg
Output Offset Voltage	Voff	(note 2)	-30	0	+30	mV
Input Clamp Voltage	Vic	(note 5)	—	2.0	—	V
Crosstalk (1)	CT1	Vi=2.0Vpp, 4.43MHz, Vo/Vi (note 3)	—	-70	—	dB
Crosstalk (2)	CT2	Vi=2.0Vpp, 4.43MHz, Vo/Vi (note 4)	—	-70	—	dB
Switch Change Voltage	Vcl	All inside SW : ON	2.4	—	—	V
	Vcl	All inside SW : OFF	—	—	0.8	V
Output Impedance	Ro		—	10	—	Ω

(note 1): If it is not shown about switch condition, it is tested on three conditions below.

a) S1=2, S2=S3=S4=S5=1 b) S2=S4=2, S1=S3=S5=1, c) S1=S2=1, S3=S5=2, S4=1 or 2.

(note 2): S1=S2=S3=1, Output DC voltage difference of three mode below.

a) S4=S5=1 b) S4=2, S5=1 c) S4=1 or 2, S5=2

(note 3): S5=1, Tested on all combination of S1~S4 except two below.

a) S1=2, S4=1 b) S2=S4=2

(note 4): Tested on all combination of S1~S4 except one.

a) S5=2, S3=2

(note 5): Input clamp voltage is about 2/5 of supply voltage.

APPLICATION

Oscillation Prevention on light loading conditions
Recommended under circuit

This IC requires $1M\Omega$ resistance between INPUT and GND pin for clamp type input since the minute current causes an unstable pin voltage.

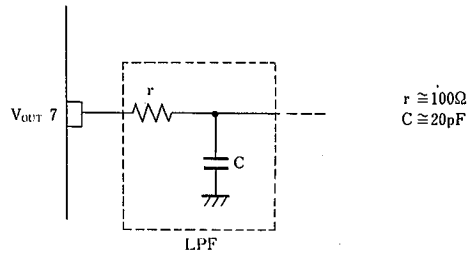

TEST CIRCUIT

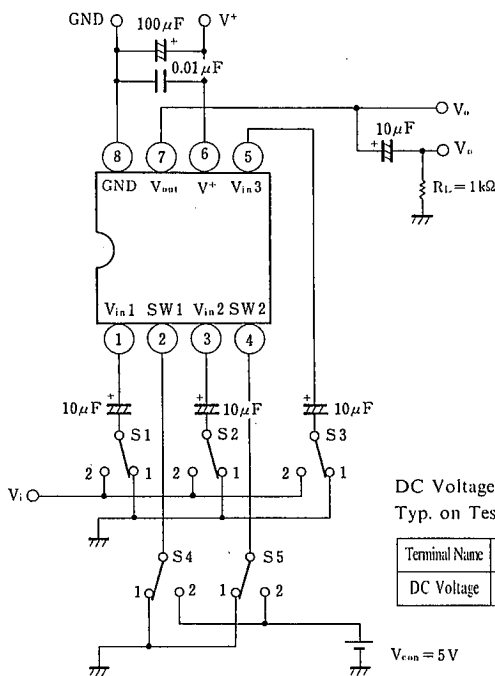

DC Voltage Each Terminal
Typ. on Test Circuit $T_a = 25^\circ\text{C}$

Terminal Name	V_{IN1}	SW1	V_{IN2}	SW2	V_{IN3}	V^+	V_{OUT}	GND
DC Voltage	$\frac{2}{3}V^+$	—	$\frac{2}{3}V^+$	—	$\frac{2}{3}V^+$	—	$\frac{2}{3}V^+ - 0.7$	—

■ EQUIVALENT CIRCUIT

PIN NO.	PIN FUNCTION	INSIDE EQUIVALENT CIRCUIT	PIN NO.	PIN FUNCTION	INSIDE EQUIVALENT CIRCUIT
1	V _{IN 1}		5	V _{IN 3} (Mute)	
2	SW 1		6	V ⁺	
3	V _{IN 2}		7	V _{OUT}	
4	SW 2		8	GND	

MEMO

[CAUTION]

The specifications on this databook are only given for information, without any guarantee as regards either mistakes or omissions. The application circuits in this databook are described only to show representative usages of the product and not intended for the guarantee or permission of any right including the industrial rights.