

Full-Swing Input and Output type Quad Operational Amplifier

■ GENERAL DESCRIPTION

NJM2734 is single supply quad operational amplifier with full swing input and output, operates from 1.8V.

Input and Output Full Swing provides wide dynamic range, is from ground to power supply level. In addition to ground sensing applications, **NJM2734** enable to be applied to Hi-side sensing applications.

The features are low noise and low operating voltage for battery management, portable audio applications, and others.

■ PACKAGE OUTLINE



NJM2734SCC

■ FEATURES

- Operating Voltage : 1.8 to 6.0V
- Input Full-Swing : $V_{ICM} = 0$ to 5.0V, at $V^+ = 5V$
- Output Full-Swing : $V_{OH} \geq 4.9V / V_{OL} \leq 0.1V$, at $V^+ = 5V, R_L = 20k\Omega$
- Load Drivability : $V_{OH} \geq 4.75V / V_{OL} \leq 0.25V$, at $V^+ = 5V, R_L = 2k\Omega$
- Offset Voltage : 5mV max.
- Slew Rate : 0.4V/ μ s typ.
- Low Input Voltage Noise : 10nV/ \sqrt{Hz} typ.
- Adequate phase margin : $\Phi_M = 75deg.$ typ., at $R_L = 2k\Omega$
- Bipolar Technology
- Package Outline : PCSP-20

NJM2734SCC

■ ABSOLUTE MAXIMUM RATINGS

(Ta=25°C)

PARAMETER	SYMBOL	RATINGS	UNIT
Supply Voltage	V ⁺	7.0	V
Differential Input Voltage Range	V _{ID}	±1.0 (Note1)	V
Common Mode Input Voltage Range	V _{IC}	0 ~ 7.0 (Note1)	V
Power Dissipation	P _D	400 [PCSP-20] (Note2)	mW
Operating Temperature Range	T _{opr}	-40~+85	°C
Storage Temperature Range	T _{stg}	-40~+125	°C

(Note1) For supply voltage less than 7V, the absolute maximum input voltage is equal to the supply voltage.

(Note2) On the PCB " EIA/JEDEC (76.2x11.43x1.6mm, two layers, FR-4) ".

■ RECOMMENDED OPERATING CONDITION

(Ta=25°C)

PARAMETER	SYMBOL	RATING	UNIT
Supply Voltage	V ⁺	1.8 to 6.0	V

■ PIN CONFIGURATION

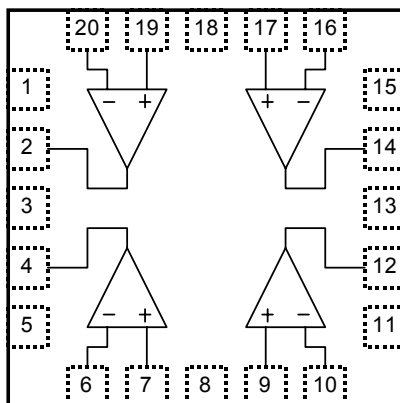

(Top View)

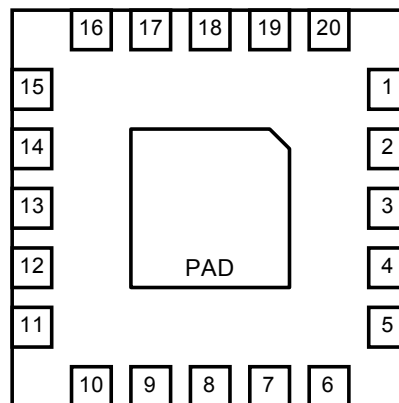

(Bottom View)

PIN CONFIGURATION

1. NC	11. NC
2. B OUTPUT	12. D OUTPUT
3. NC	13. NC
4. C OUTPUT	14. A OUTPUT
5. NC	15. NC
6. C -INPUT	16. A -INPUT
7. C +INPUT	17. A +INPUT
8. GND	18. V ⁺
9. D +INPUT	19. B +INPUT
10. D -INPUT	20. B -INPUT

(Note3) The NC pin and the PAD should connect with a GND terminal.

(Note4) The NC pin is electrically not connected to the die in a package.

(Note5) The PAD is electrically not connected to the backside of the die. The PAD cannot be used as GND pin.

■ **ELECTRICAL CHARACTERISTICS** ($V^+=5V, T_a=25^\circ C$)

● **DC CHARACTERISTICS**

($V^+=5V, T_a=25^\circ C$)

PARAMETER	SYMBOL	TEST CONDITION	MIN.	TYP.	MAX.	UNIT
Operating Current	I_{CC}	No signal applied	-	1.2	1.8	mA
Input Offset Voltage	V_{IO}		-	1	5	mV
Input Bias Current	I_B		-	50	250	nA
Input Offset Current	I_{IO}		-	5	100	nA
Large Signal Voltage Gain	A_V	$R_L=2k\Omega$ to 2.5V	60	85	-	dB
Common Mode Rejection Ratio	CMR	CMR+: $2.5V \leq V_{CM} \leq 5V$ (Note6) CMR -: $0V \leq V_{CM} \leq 2.5V$ (Note6)	55	70	-	dB
Supply Voltage Rejection Ratio	SVR	$V^+/V = \pm 2.0V \sim \pm 3.0V$	70	85	-	dB
Maximum Output Voltage 1	V_{OH1}	$R_L=20k\Omega$ to 2.5V	4.9	4.95	-	V
	V_{OL1}	$R_L=20k\Omega$ to 2.5V	-	0.05	0.1	V
Maximum Output Voltage 2	V_{OH2}	$R_L=2k\Omega$ to 2.5V	4.75	4.85	-	V
	V_{OL2}	$R_L=2k\Omega$ to 2.5V	-	0.15	0.25	V
Input Common Mode Voltage Range	V_{ICM}	CMR \geq 55dB	0	-	5	V

(Note6) CMR is represented by either CMR+ or CMR- has lower value.

CMR+ is measured with $2.5V \leq V_{CM} \leq 5.0$ and CMR- is measured with $0V \leq V_{CM} \leq 2.5V$.

● **AC CHARACTERISTICS**

($V^+=5V, T_a=25^\circ C$)

PARAMETER	SYMBOL	TEST CONDITION	MIN.	TYP.	MAX.	UNIT
Unity Gain Bandwidth	GB	$R_L=2k\Omega$ to 2.5V	-	1	-	MHz
Phase Margin	Φ_M	$R_L=2k\Omega$ to 2.5V	-	75	-	Deg
Equivalent Input Noise Voltage	V_{NI}	$f=1kHz$	-	10	-	nV/ \sqrt{Hz}
Amp to Amp Separation	CS	$f=1kHz,$ $R_L=2k\Omega$ to 2.5V, $V_o=1.2V_{rms}$	-	133	-	dB

● **TRANSIENT CHARACTERISTICS**

($V^+=5V, T_a=25^\circ C$)

PARAMETER	SYMBOL	TEST CONDITION	MIN.	TYP.	MAX.	UNIT
Slew Rate	SR	$R_L=2k\Omega$ to 2.5V	-	0.4	-	V/ μs

NJM2734SCC

■ ELECTRICAL CHARACTERISTICS ($V^+=3V$, $T_a=25^\circ C$)

●DC CHARACTERISTICS

($V^+=3V$, $T_a=25^\circ C$)

PARAMETER	SYMBOL	TEST CONDITION	MIN.	TYP.	MAX.	UNIT
Operating Current	I_{CC}	No signal applied	-	1	1.8	mA
Input Offset Voltage	V_{IO}		-	1	5	mV
Input Bias Current	I_B		-	50	250	nA
Input Offset Current	I_{IO}		-	5	100	nA
Large Signal Voltage Gain	A_V	$R_L=2k\Omega$ to 1.5V	60	84	-	dB
Common Mode Rejection Ratio	CMR	CMR+: $1.5V \leq V_{CM} \leq 3V$ (Note7) CMR -: $0V \leq V_{CM} \leq 1.5V$ (Note7)	48	63	-	dB
Supply Voltage Rejection Ratio	SVR	$V^+/V = \pm 1.2V \sim \pm 2.0V$	68	83	-	dB
Maximum Output Voltage 1	V_{OH1}	$R_L=20k\Omega$ to 1.5V	2.9	2.95	-	V
	V_{OL1}	$R_L=20k\Omega$ to 1.5V	-	0.05	0.1	V
Maximum Output Voltage 2	V_{OH2}	$R_L=2k\Omega$ to 1.5V	2.75	2.85	-	V
	V_{OL2}	$R_L=2k\Omega$ to 1.5V	-	0.15	0.25	V
Input Common Mode Voltage Range	V_{ICM}	CMR \geq 48dB	0	-	3	V

(Note7) CMR is represented by either CMR+ or CMR- has lower value.

CMR+ is measured with $1.5V \leq V_{CM} \leq 3.0$ and CMR- is measured with $0V \leq V_{CM} \leq 1.5V$.

●AC CHARACTERISTICS

($V^+=3V$, $T_a=25^\circ C$)

PARAMETER	SYMBOL	TEST CONDITION	MIN.	TYP.	MAX.	UNIT
Unity Gain Bandwidth	GB	$R_L=2k\Omega$ to 1.5V	-	1	-	MHz
Phase Margin	Φ_M	$R_L=2k\Omega$ to 1.5V	-	75	-	Deg
Equivalent Input Noise Voltage	V_{NI}	$f=1kHz$	-	10	-	nV/ \sqrt{Hz}
Amp to Amp Separation	CS	$f=1kHz$ $R_L=2k\Omega$ to 1.5V, $V_o=0.7V_{rms}$	-	130	-	dB

●TRANSIENT CHARACTERISTICS

($V^+=3V$, $T_a=25^\circ C$)

PARAMETER	SYMBOL	TEST CONDITION	MIN.	TYP.	MAX.	UNIT
Slew Rate	SR	$R_L=2k\Omega$ to 1.5V	-	0.35	-	V/ μs

■ ELECTRICAL CHARACTERISTICS ($V^+=1.8V, T_a=25^\circ C$)

●DC CHARACTERISTICS

($V^+=1.8V, T_a=25^\circ C$)

PARAMETER	SYMBOL	TEST CONDITION	MIN.	TYP.	MAX.	UNIT
Operating Current	I_{CC}	No signal applied	-	0.9	1.6	mA
Input Offset Voltage	V_{IO}		-	1	5	mV
Input Bias Current	I_B		-	50	250	nA
Input Offset Current	I_{IO}		-	5	100	nA
Large Signal Voltage Gain	A_V	$R_L=2k\Omega$ to 0.9V	60	83	-	dB
Common Mode Rejection Ratio	CMR	CMR+: $0.9 \leq V_{CM} \leq 1.8V$ (Note8) CMR-: $0V \leq V_{CM} \leq 0.9V$ (Note8)	40	55	-	dB
Supply Voltage Rejection Ratio	SVR	$V^+/V = \pm 0.9V \sim \pm 1.2V$	65	80	-	dB
Maximum Output Voltage 1	V_{OH1}	$R_L=20k\Omega$ to 0.9V	1.7	1.75	-	V
	V_{OL1}	$R_L=20k\Omega$ to 0.9V	-	0.05	0.1	V
Maximum Output Voltage 2	V_{OH2}	$R_L=2k\Omega$ to 0.9V	1.55	1.65	-	V
	V_{OL2}	$R_L=2k\Omega$ to 0.9V	-	0.15	0.25	V
Input Common Mode Voltage Range	V_{ICM}	CMR \geq 40dB	0	-	1.8	V

(Note8) CMR is represented by either CMR+ or CMR- has lower value.

CMR+ is measured with $0.9V \leq V_{CM} \leq 1.8$ and CMR- is measured with $0V \leq V_{CM} \leq 0.9V$.

●AC CHARACTERISTICS

($V^+=1.8V, T_a=25^\circ C$)

PARAMETER	SYMBOL	TEST CONDITION	MIN.	TYP.	MAX.	UNIT
Unity Gain Bandwidth	GB	$R_L=2k\Omega$ to 0.9V	-	1	-	MHz
Phase Margin	Φ_M	$R_L=2k\Omega$ to 0.9V	-	75	-	Deg
Equivalent Input Noise Voltage	V_{NI}	$f=1kHz$	-	10	-	nV/ \sqrt{Hz}
Amp to Amp Separation	CS	$f=1kHz$ $R_L=2k\Omega$ to 0.9V, $V_o=0.4V_{rms}$	-	125	-	dB

●TRANSIENT CHARACTERISTICS

($V^+=1.8V, T_a=25^\circ C$)

PARAMETER	SYMBOL	TEST CONDITION	MIN.	TYP.	MAX.	UNIT
Slew Rate	SR	$R_L=2k\Omega$ to 0.9V	-	0.3	-	V/ μs

Typical Characteristics

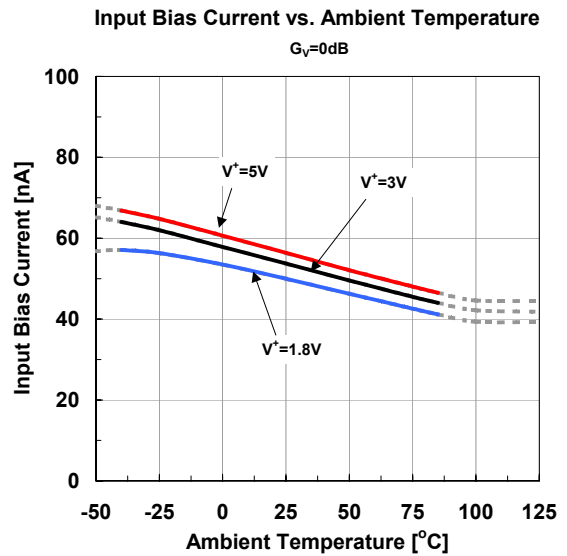
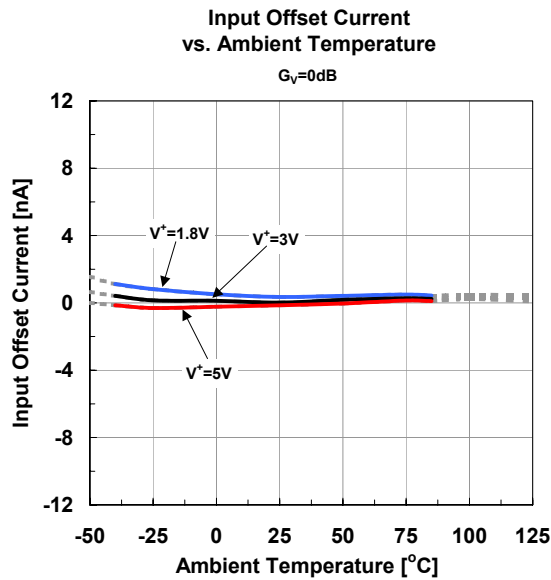
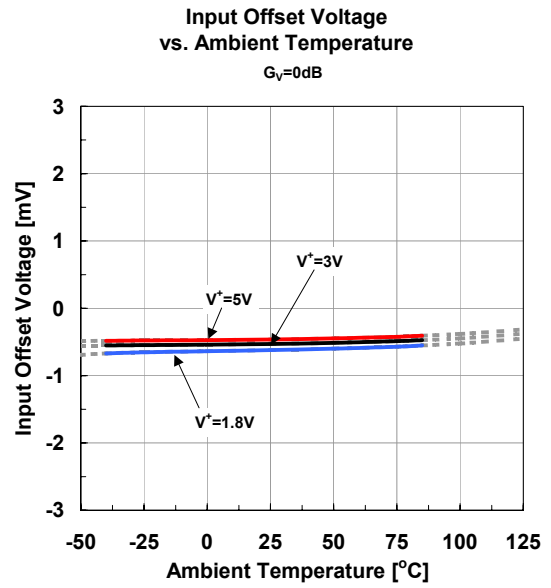
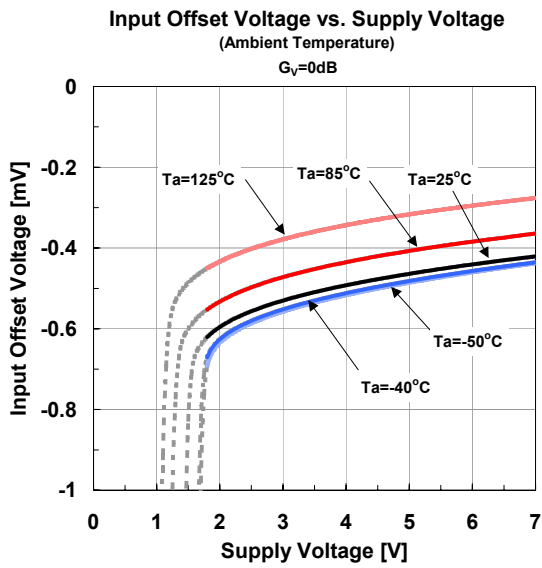
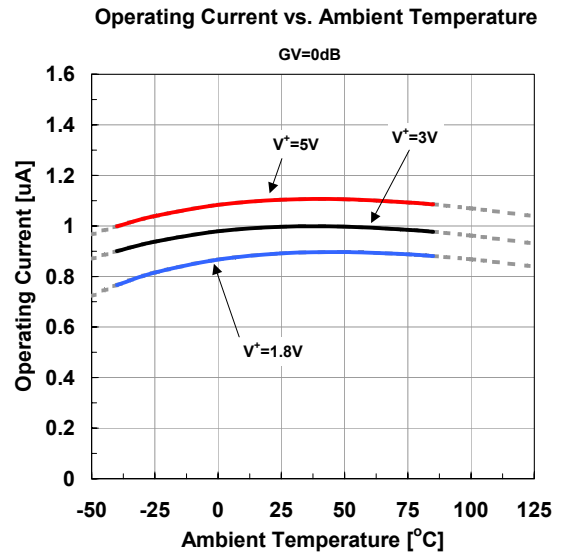
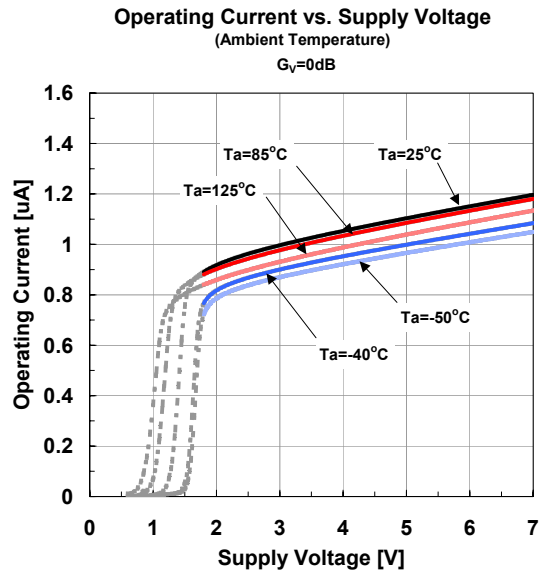

Typical Characteristics

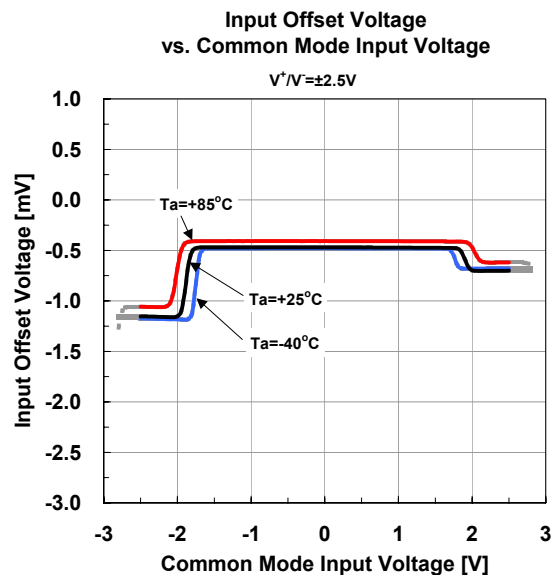
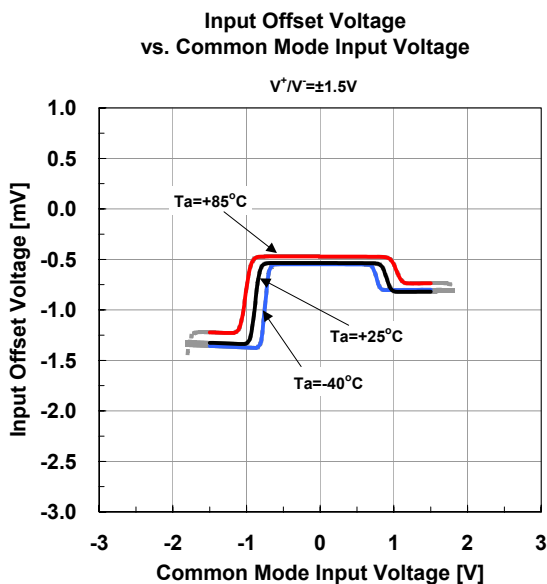
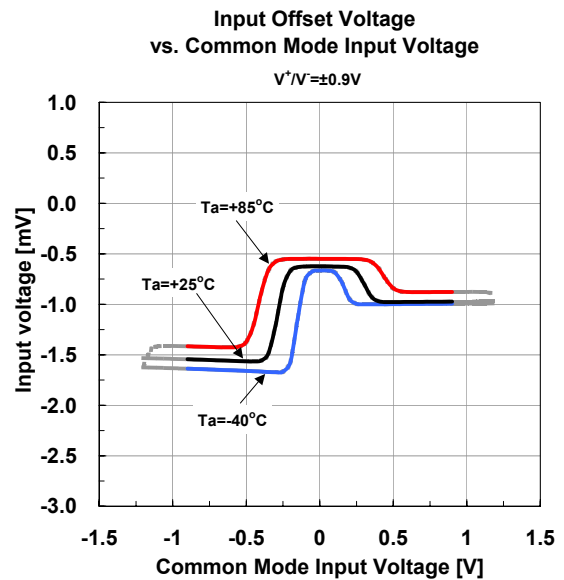
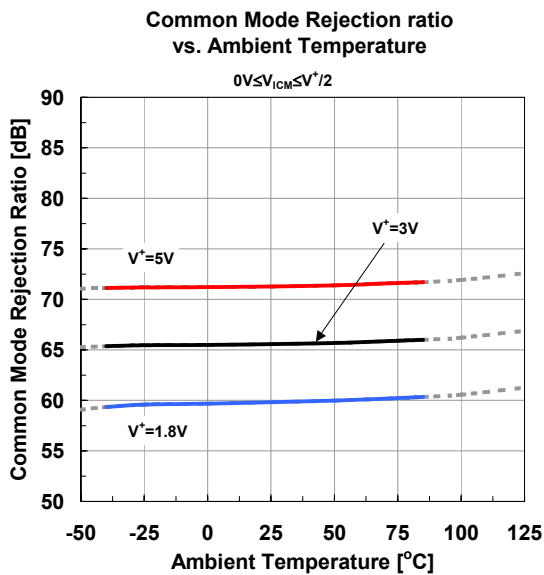
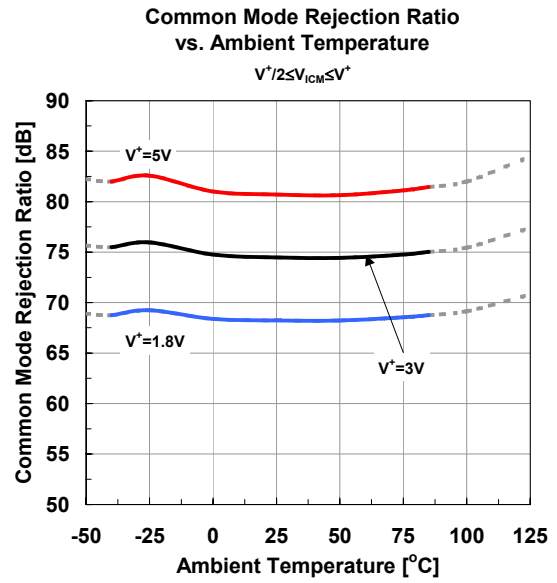
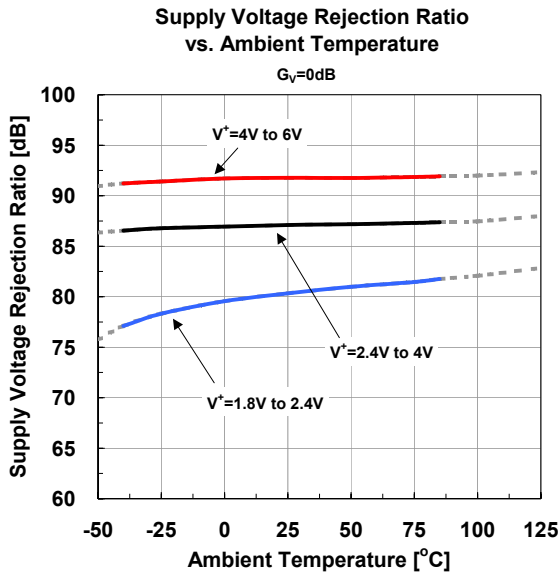

■ Typical Characteristics

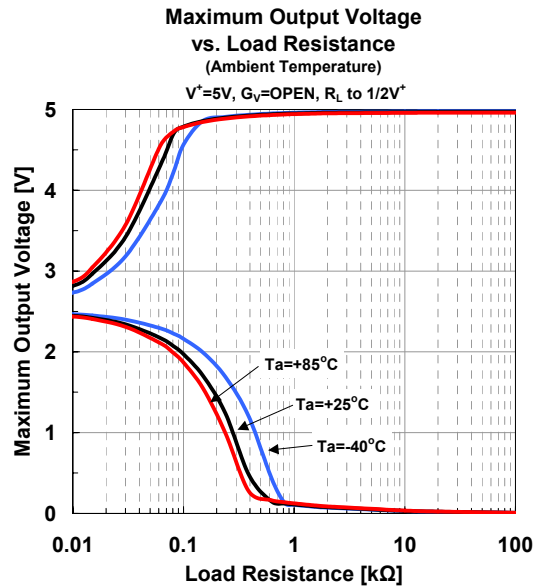
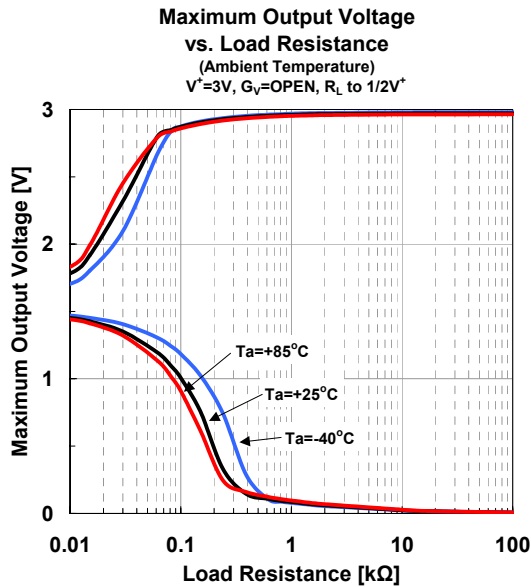
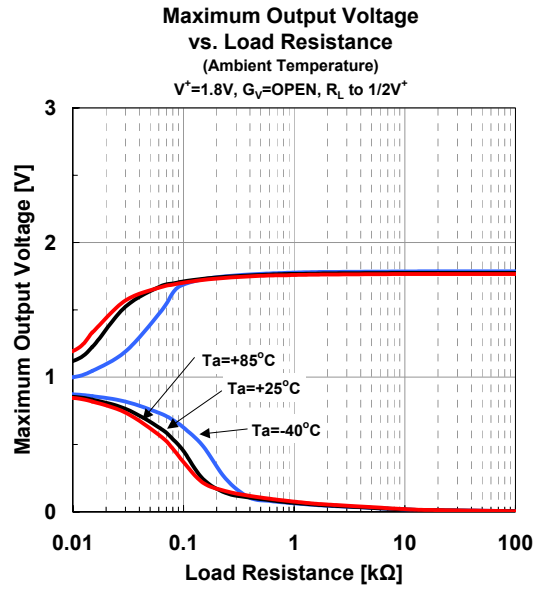
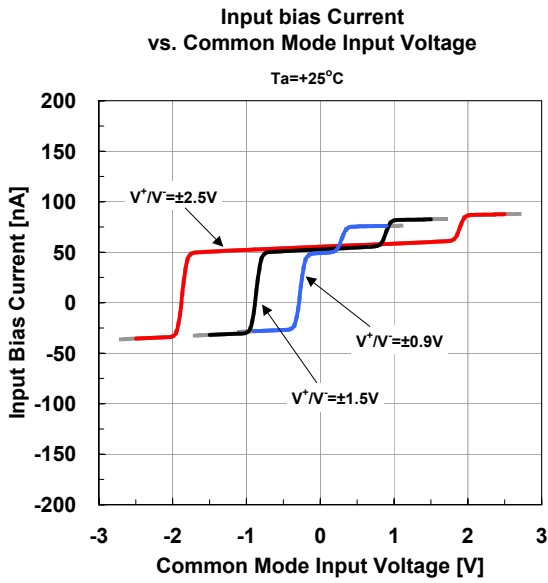

■ Typical Characteristics

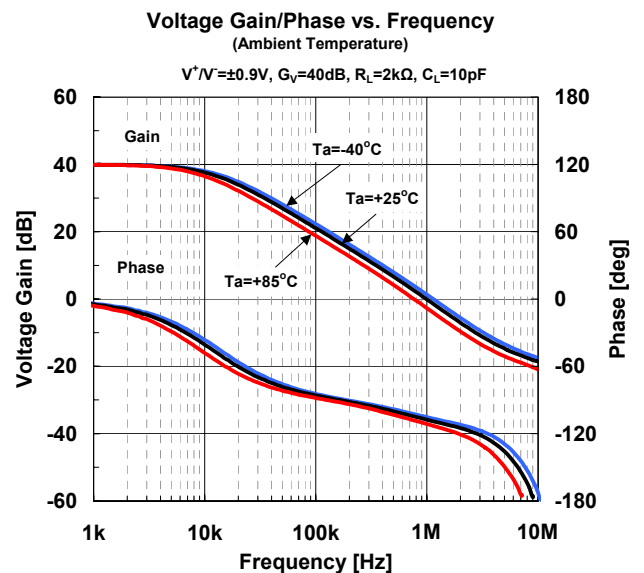
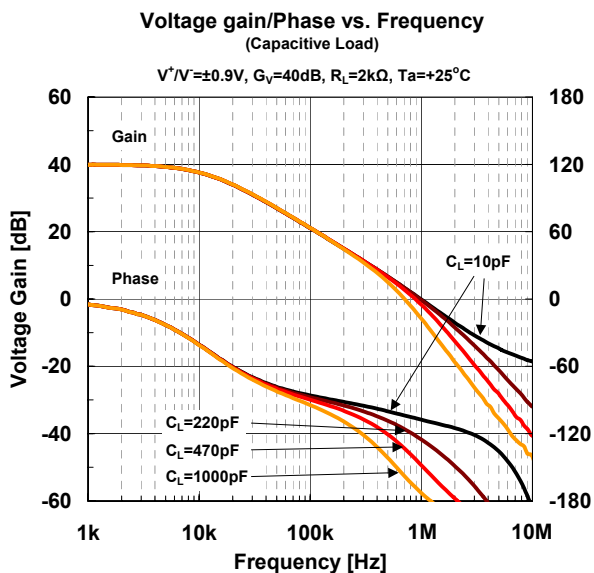
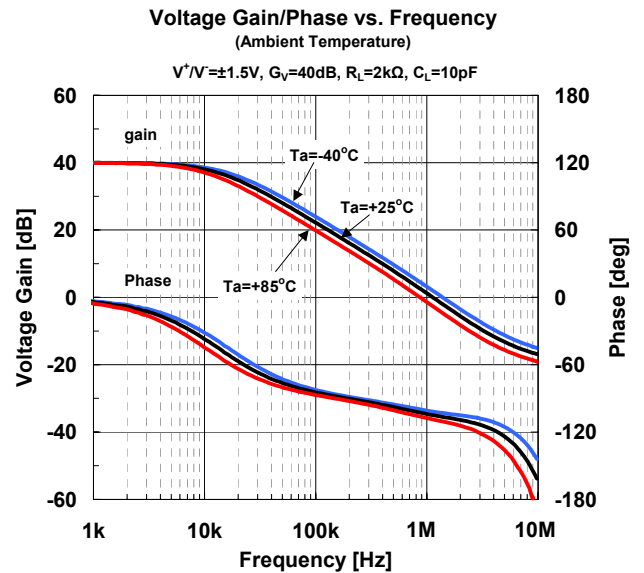
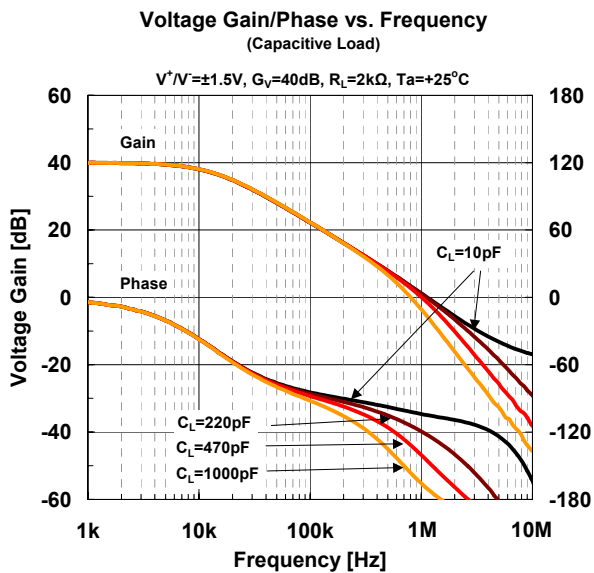
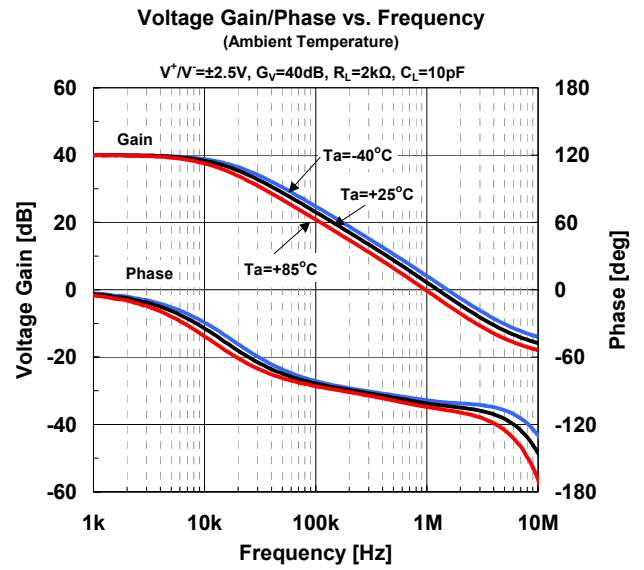
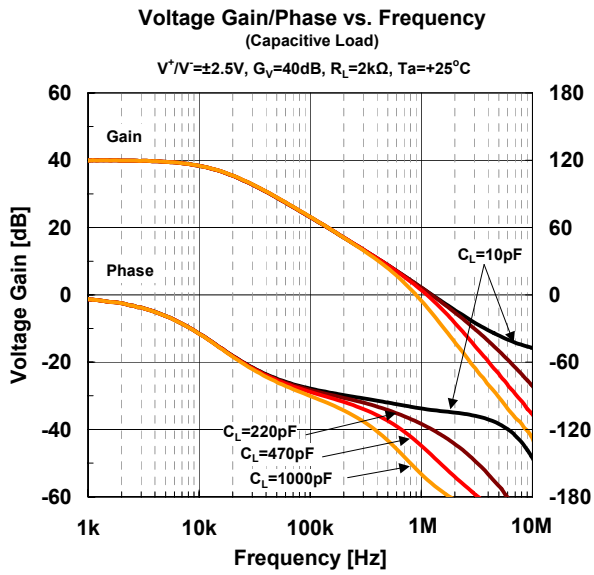

Typical Characteristics

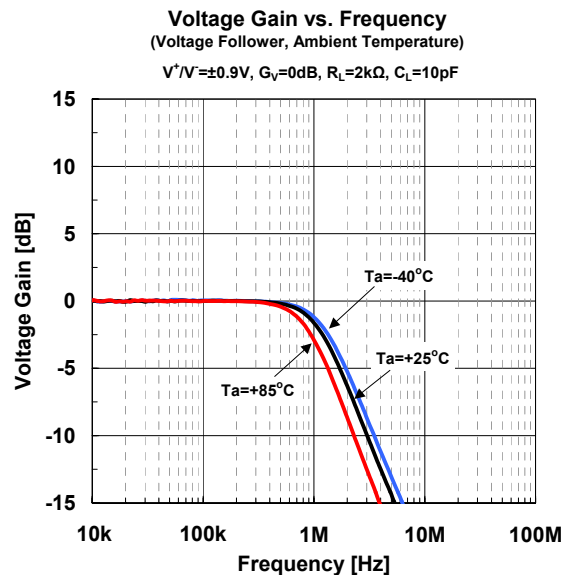
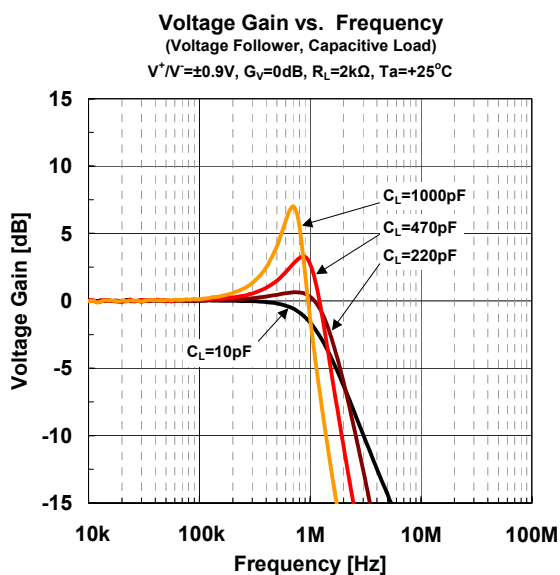
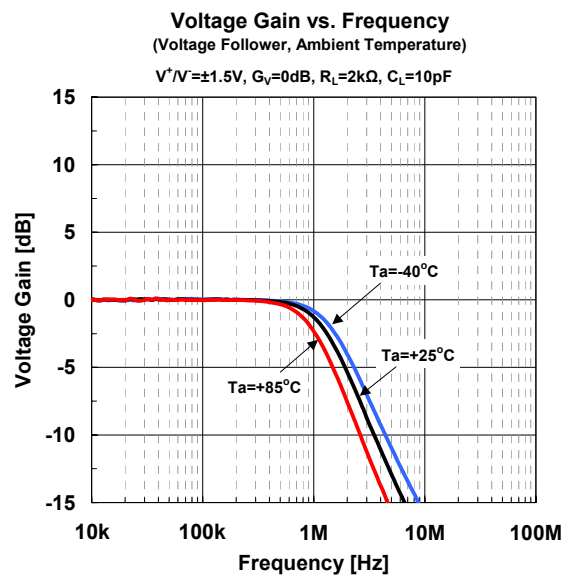
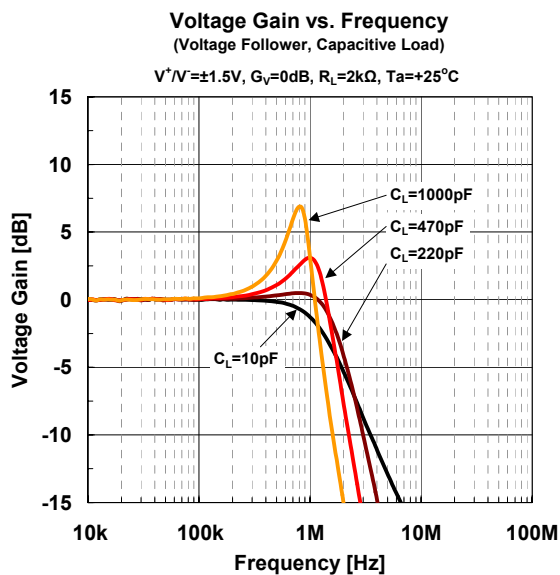
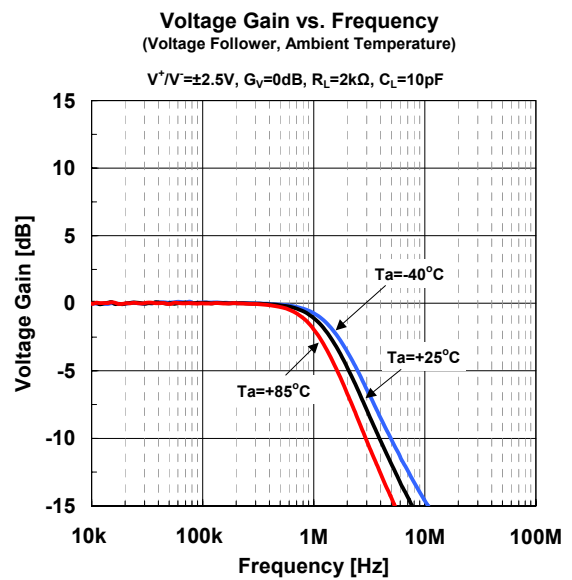
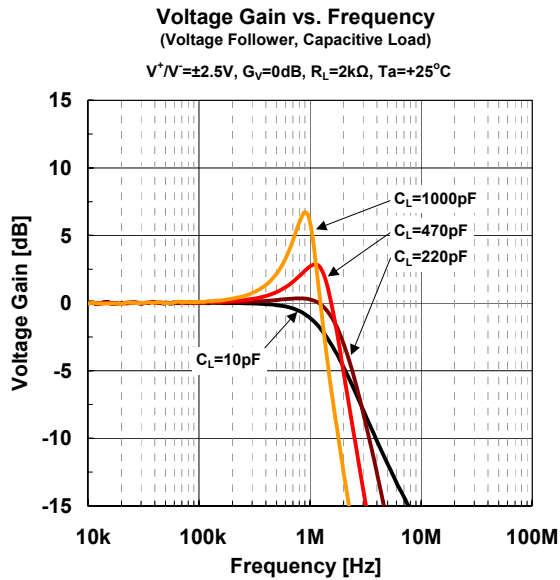

Typical Characteristics

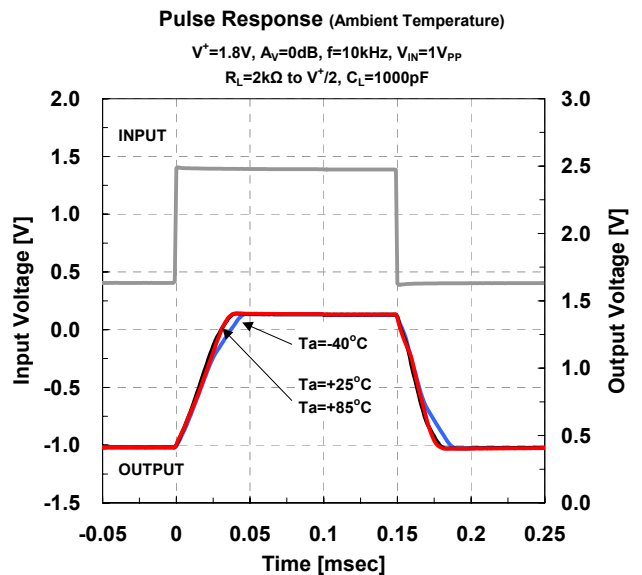
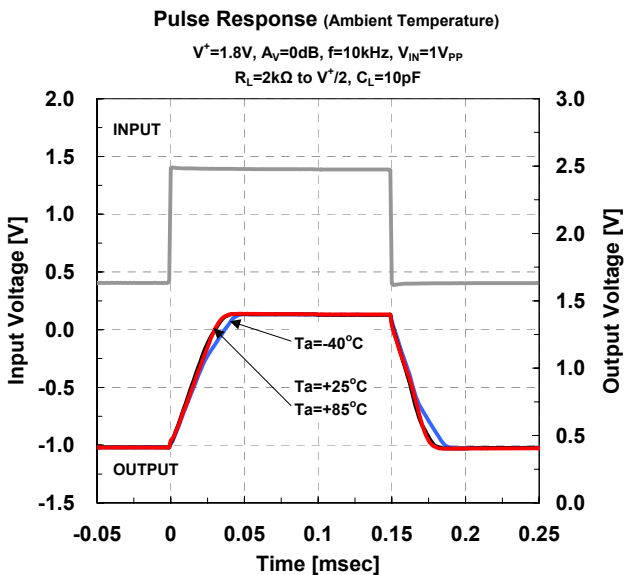
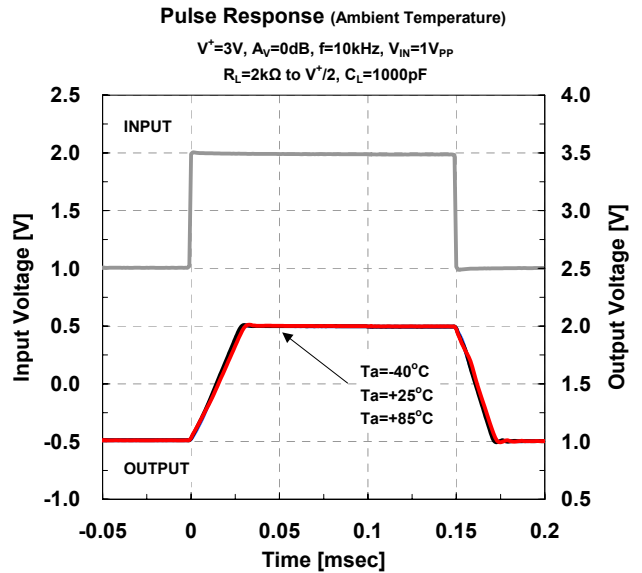
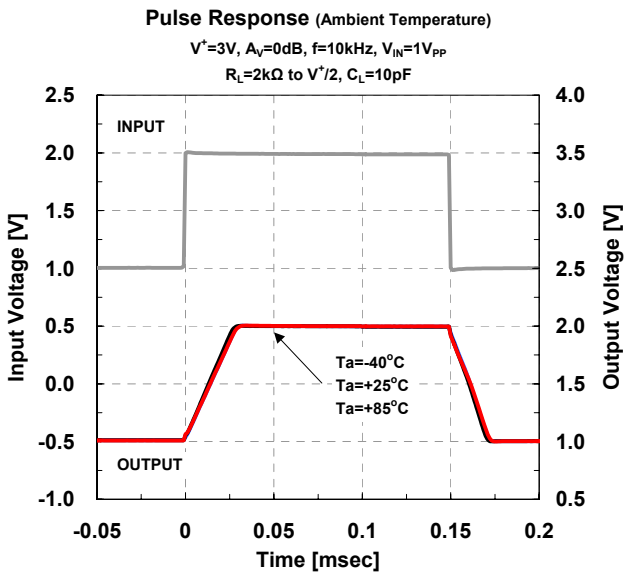
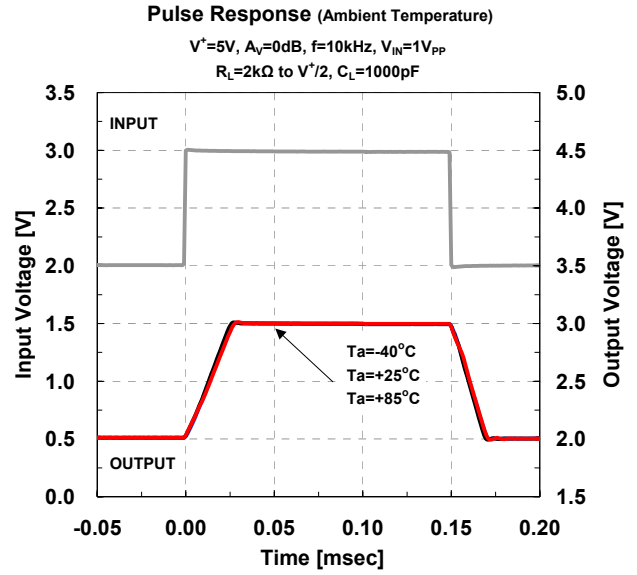
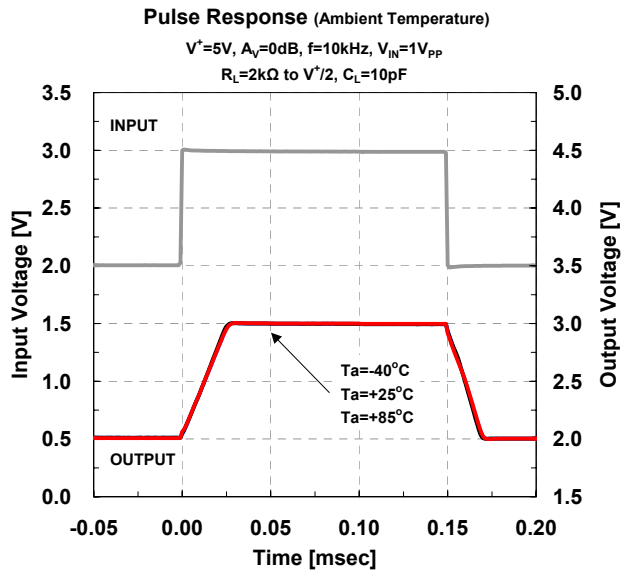

■ Typical Characteristics

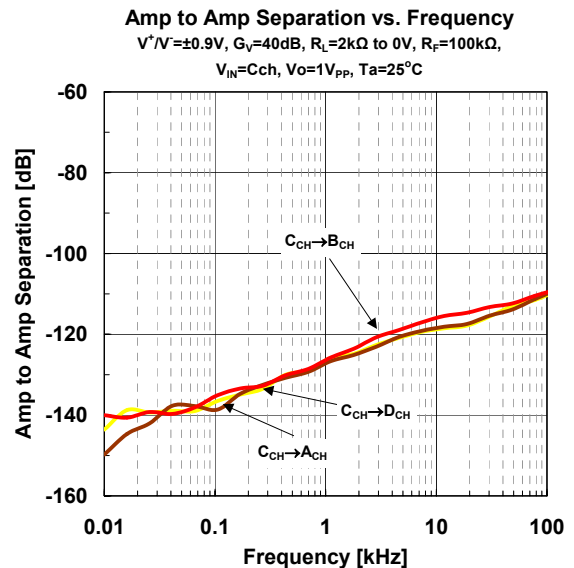
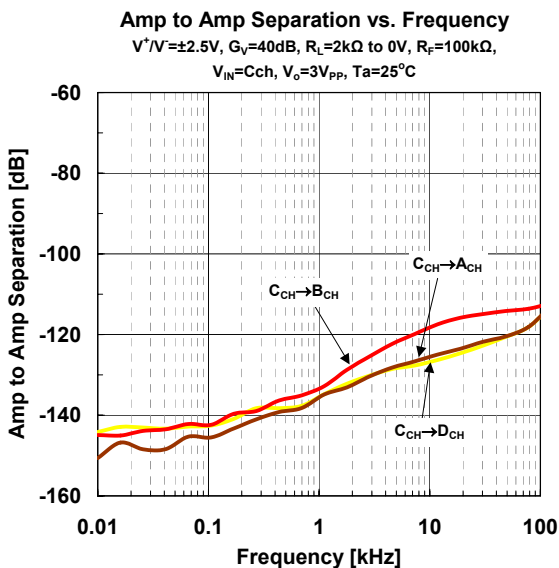
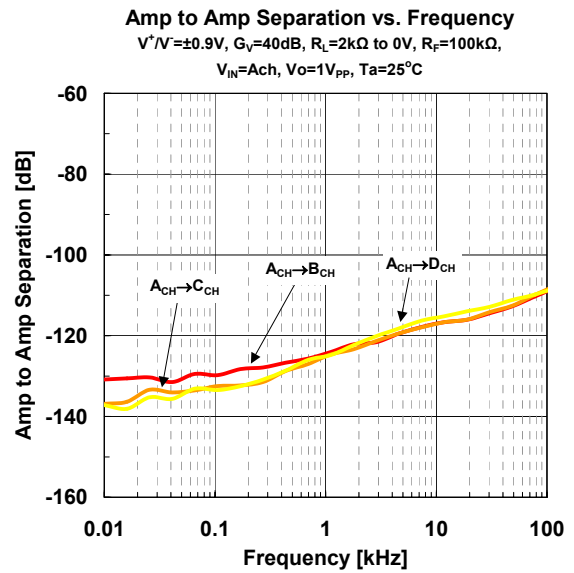
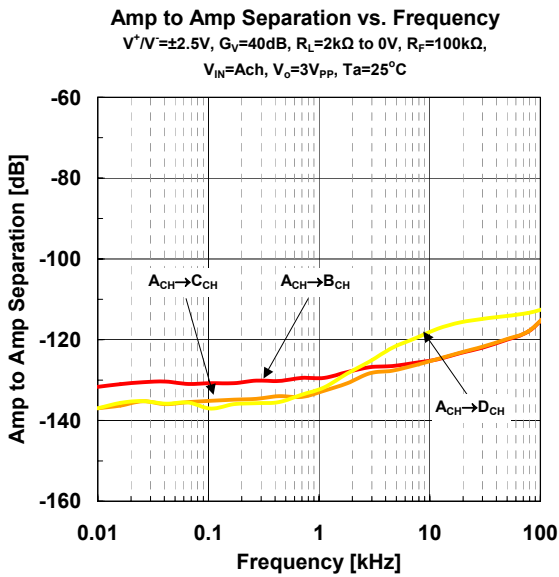
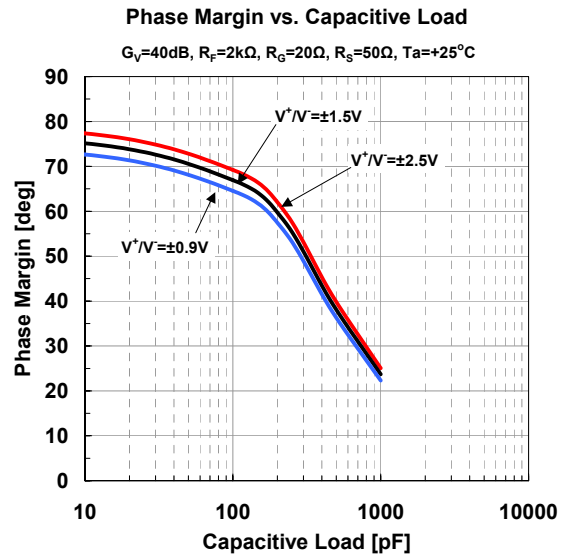
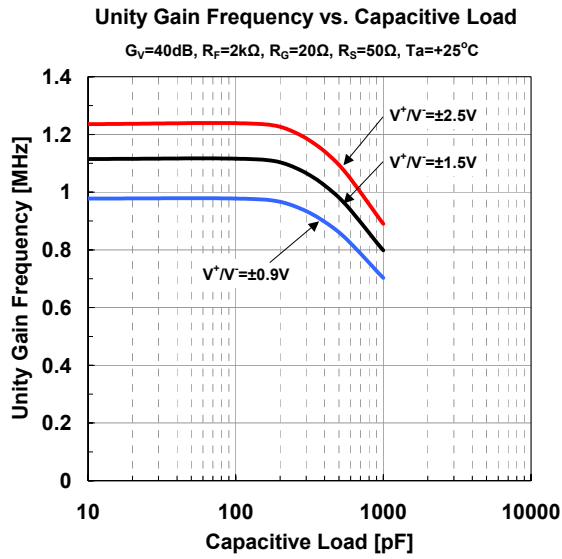

■ Typical Characteristics

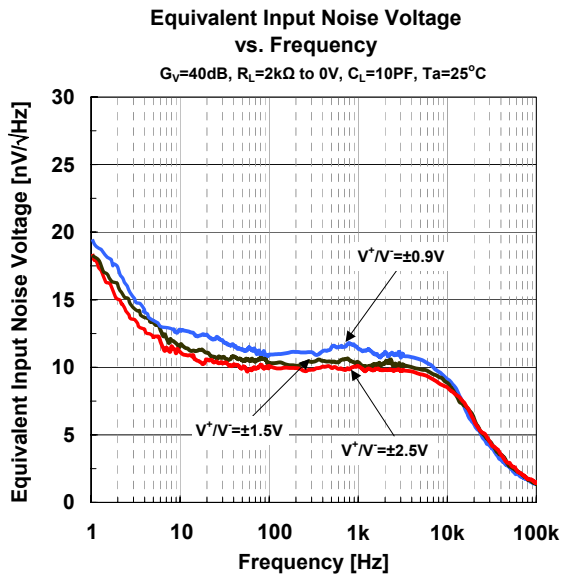
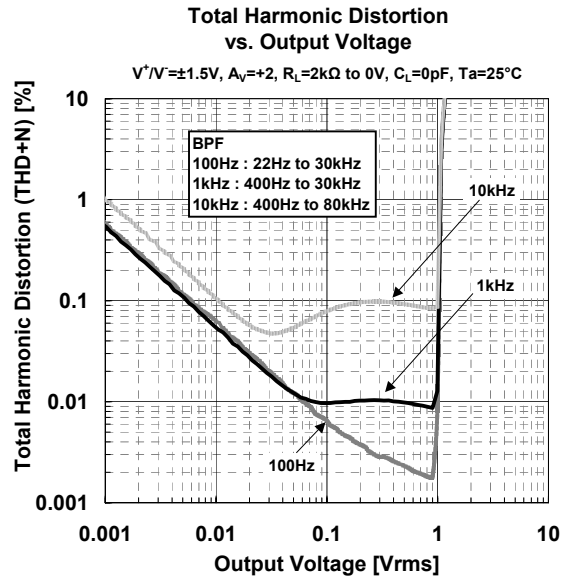
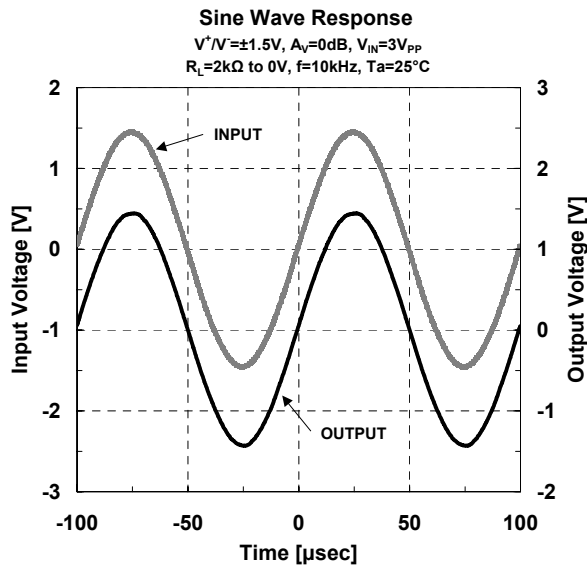

[CAUTION]
 The specifications on this databook are only given for information, without any guarantee as regards either mistakes or omissions. The application circuits in this databook are described only to show representative usages of the product and not intended for the guarantee or permission of any right including the industrial rights.