

# AN1432MS

## Variable output, low voltage operation shunt regulator IC

### ■ Overview

The AN1432MS is a low voltage operation and positive voltage variable output type shunt regulator IC. Since the output voltage is adjustable from approximately 1.26 V to 15 V, it is suitable for a power supply of small-sized 3 V-system portable equipment. Also, it contributes to the miniaturization of set equipment by the adoption of the small type surface mounting package.

### ■ Features

- High precision reference voltage: 1.26 V (allowance:  $\pm 2\%$ )
- Low voltage operation: 1.26 V to 15 V
- Small type surface mounting package

### ■ Applications

- Portable telephone, PHS, office automation equipment, and other small-sized portable equipment

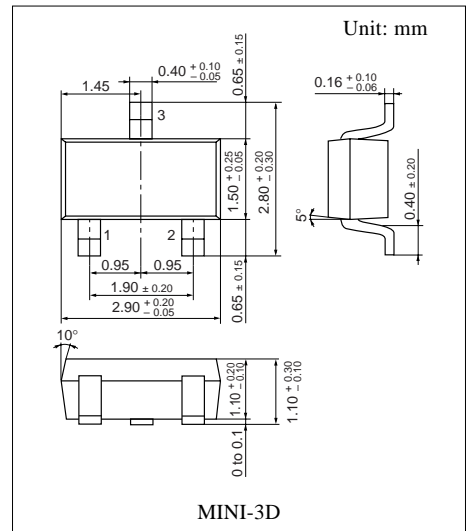

### ■ Block Diagram

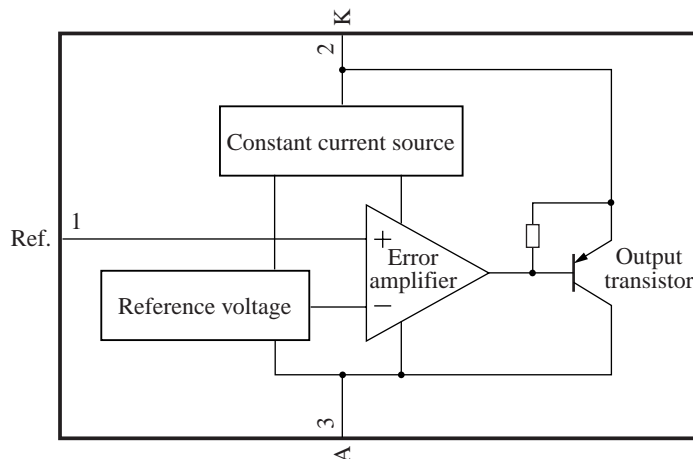

### ■ Pin Descriptions

Pin No.	Symbol	Description
1	Reference	The reference voltage (1.26 V typical) pin. Although the impedance is high under the normal using conditions, be careful that the impedance drops and current flows into the IC inside if a current or voltage is forced to apply from the outside.
2	Cathode	The pin for the combined use of the power source current supply of IC and the constant voltage output as the shunt regulator. An excessive current supplied to this pin is bypassed to the anode pin through the output transistor.
3	Anode	The constant voltage reference pin of the shunt regulator and flows out the current from the cathode and reference. Usually grounded.

### ■ Absolute Maximum Ratings

Parameter	Symbol	Rating	Unit
Supply voltage	$V_K$	15	V
Reference voltage	$V_{REF}$	7	V
Supply current	$I_K$	20	mA
Reference current	$I_{REF}$	50	$\mu$ A
Cathode — anode reverse current	$-I_{KA}$	-10	mA
Cathode — reference reverse current	$-I_{KR}$	-10	mA
Power dissipation *2	$P_D$	104	mW
Operating ambient temperature *1	$T_{opr}$	-30 to +85	$^{\circ}$ C
Storage temperature *1	$T_{stg}$	-55 to +150	$^{\circ}$ C

Note) 1. Do not apply external currents or voltages to any pins not specifically mentioned.

For circuit currents, '+' denotes current flowing into the IC, and '-' denotes current flowing out of the IC.

2. \*1: Except for the operating ambient temperature and storage temperature, all ratings are for  $T_a = 25^{\circ}$ C.

\*2: The value at  $T_a = 85^{\circ}$ C.

### ■ Recommended Operating Range

Parameter	Symbol	Range	Unit
Supply voltage	$V_{CC}$	$V_{REF}$ to 15	V

### ■ Electrical Characteristics at $T_a = 25^{\circ}$ C

Parameter	Symbol	Conditions	Min	Typ	Max	Unit
Reference voltage	$V_{REF}$	$V_{KA} = V_{REF}$ , $I_K = 10$ mA	1.235	1.26	1.285	V
Reference voltage fluctuation 1	$\Delta V_{REF} / \Delta V_{KA}$	$ V_{REF}  \leq V_{KA} \leq 5$ V, $I_K = 10$ mA	—	1.9	3.5	mV/V
Reference voltage fluctuation 2	$\Delta V_{REF} / \Delta V_{KA}$	$5$ V $\leq V_{KA} \leq 15$ V, $I_K = 10$ mA	—	1.0	2.0	mV/V
Reference input current	$I_{REF}$	$R_I = 10$ k $\Omega$ , $I_K = 10$ mA	—	2.5	4.4	$\mu$ A
Minimum cathode current	$I_{K\ min}$	$V_{KA} = V_{REF}$	—	290	350	$\mu$ A
Off time cathode current	$I_{K\ OFF}$	$V_{KA} = 15$ V, $V_{REF} = 0$ V	—	—	1.0	$\mu$ A
Dynamic impedance	$ Z_{KA} $	$V_{KA} = V_{REF}$ , $f \leq 1$ kHz, $I_K = 1$ mA to 10 mA	—	0.1	0.5	$\Omega$

■ Electrical Characteristics at  $T_a = 25^\circ\text{C}$  (continued)

• Design reference data

Note) The characteristics listed below are theoretical values based on the IC design and are not guaranteed.

Parameter	Symbol	Conditions	Reference value	Unit
Reference voltage change with temperature	$\Delta V_{REF} / \Delta T_a$	$V_{KA} = V_{REF}, I_{KA} = 10 \text{ mA}$ $0^\circ\text{C} \leq T_a \leq +70^\circ\text{C}$	3	mV
Reference input current change with temperature	$\Delta I_{REF} / \Delta T_a$	$R_1 = 10 \text{ k}\Omega, I_K = 10 \text{ mA}$ $0^\circ\text{C} \leq T_a \leq +70^\circ\text{C}$	0.4	$\mu\text{A}$

■ Application Notes

•  $P_D - T_a$  curves of mini-type 3-pin package

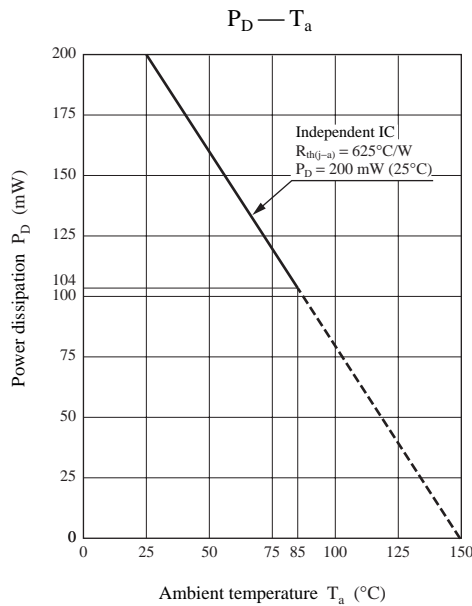

■ Application Circuit Example

This circuit amplifies the error voltage of the secondary side output voltage in the insulation type switching power supply, then transfer it to the primary side via a photocoupler.

Replaceable with the conventional product (AN1431M/AN1431T).

