

AN48830B

Low current consumption, high sensitivity CMOS Hall IC
Operate by the value of magnetic flux density, regardless of polarity

Overview

The AN48830B is a Hall IC (a magnetic sensor) which has 2 times or more sensitivity and a low current consumption of about one three-hundredth compared with our conventional one.

In this Hall IC, a Hall element, a offset cancel circuit, an amplifier circuit, a sample and hold circuit, a Schmidt circuit, and output stage FET are integrated on a single chip housed in a small package by IC technique.

Features

- Either North nor South magnetic pole can be selected *
- High sensitivity (6 mT max.) due to offset cancel circuit and a new sample and hold circuit
- Small current by using intermittent action
(Average supply current: 3.5 μ A typ.)
- Small package (SMD)
- CMOS inverter output (output form logic)

Applications

- Flip type cellular phone, digital video camera

Block Diagram

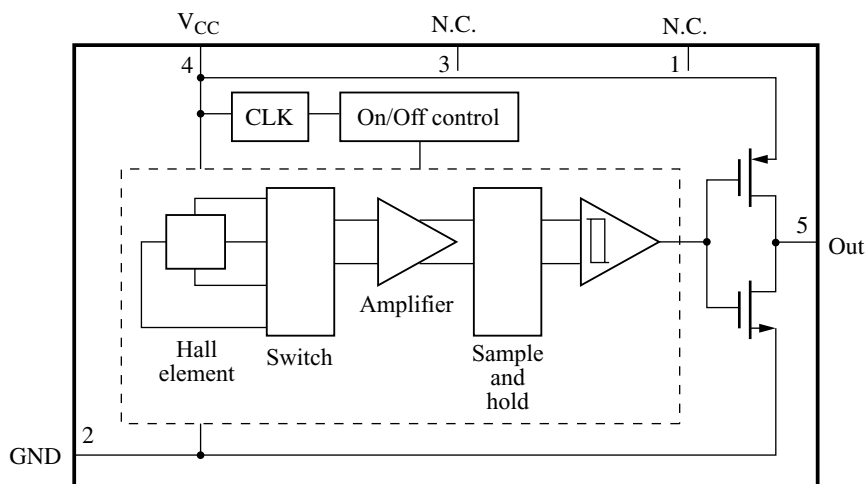

Pin Descriptions

Pin No.	Symbol	Description	Pin No.	Symbol	Description
1	N.C.	—	4	V _{CC}	Power supply
2	GND	Ground	5	Out	Output
3	N.C.	—			

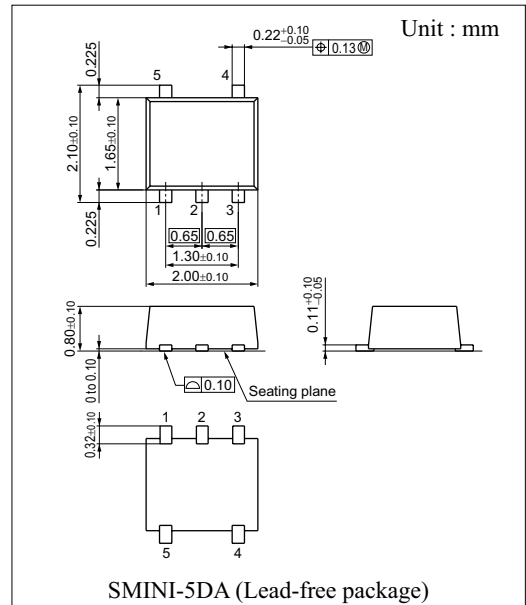

Note) *:

Magnetic flux density

AN48830B output

Conventional model output

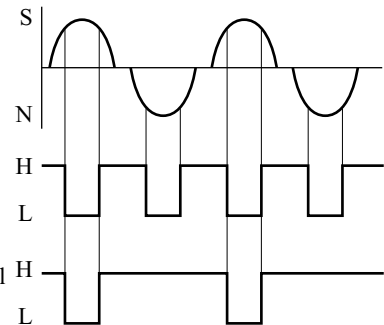

■ Absolute Maximum Ratings

Parameter	Symbol	Rating	Unit
Supply voltage	V_{CC}	5	V
Output voltage	V_{OUT}	5	V
Supply current	I_{CC}	5	mA
Output current	I_{OUT}	15	mA
Power dissipation *1, *2	P_D	60	mW
Operating ambient temperature *1	T_{opr}	-25 to +75	°C
Storage temperature *1	T_{stg}	-55 to +125	°C

Note) *1: Except for the power dissipation, operating ambient temperature and storage temperature, all ratings are for $T_a = 25^\circ\text{C}$.

*2: $T_a = 75^\circ\text{C}$. For the independent IC without a heat sink. Please use within the range of power dissipation, referring to $P_D - T_a$ curve.

■ Recommended Operating Range

Parameter	Symbol	Range	Unit
Supply voltage	V_{CC}	2.5 to 3.5	V

■ Electrical Characteristics $T_a = 25^\circ\text{C} \pm 2^\circ\text{C}$

Parameter	Symbol	Conditions	Min	Typ	Max	Unit
Operating magnetic flux density 1	B_{H-LS}	$V_{CC} = 3\text{ V}$	—	—	6	mT
Operating magnetic flux density 2 *1	B_{H-LN}	$V_{CC} = 3\text{ V}$	-6	—	—	mT
Operating magnetic flux density 3 *2	B_{L-HS}	$V_{CC} = 3\text{ V}$	0.5	—	—	mT
Operating magnetic flux density 4 *2	B_{L-HN}	$V_{CC} = 3\text{ V}$	—	—	-0.5	mT
Output voltage 1	V_{OLS}	$V_{CC} = 3\text{ V}, I_O = 2\text{ mA}, B = 6.0\text{ mT}$	—	0.1	0.3	V
Output voltage 2	V_{OLN}	$V_{CC} = 3\text{ V}, I_O = 2\text{ mA}, B = -6.0\text{ mT}$	—	0.1	0.3	V
Output voltage 3	V_{OHS}	$V_{CC} = 3\text{ V}, I_O = -2\text{ mA}, B = 0.5\text{ mT}$	2.7	2.9	—	V
Output voltage 4	V_{OHN}	$V_{CC} = 3\text{ V}, I_O = -2\text{ mA}, B = -0.5\text{ mT}$	2.7	2.9	—	V
Supply current 1 *3	$I_{CC_{AVE}}$	$V_{CC} = 3\text{ V}$	—	3.5	7.0	μA

Note) *1: Symbol B_{H-LS} , B_{H-LN} stands for the operating magnetic flux density where its output level varies from high to low.

*2: Symbol B_{L-HS} , B_{L-HN} stands for the operating magnetic flux density where its output level varies from low to high.

*3: $I_{CC_{AVE}} = \{I_{CC_{ON}} \times t_{ON} + I_{CC_{OFF}} \times t_{OFF}\} / \{t_{ON} + t_{OFF}\}$

• Design reference data

Parameter	Symbol	Conditions	Min	Typ	Max	Unit
Hysteresis width 1	BWS	$V_{CC} = 3\text{ V}$	—	1.2	—	mT
Hysteresis width 2	BWN	$V_{CC} = 3\text{ V}$	—	1.2	—	mT
Supply current 2	$I_{CC_{ON}}$	$V_{CC} = 3\text{ V}$	—	1.4	—	mA
Supply current 3	$I_{CC_{OFF}}$	$V_{CC} = 3\text{ V}$	—	2	—	μA
Operating time	t_{ON}	$V_{CC} = 3\text{ V}$	—	20	—	μs
Stop time	t_{OFF}	$V_{CC} = 3\text{ V}$	—	20.5	—	ms

Note) It will operate normally in approximately 41 ms after power on.

Individual Specification

■ Technical Data

- Position of a Hall element (unit in mm)

Distance from a package surface to sensor part: 0.39 mm (reference value)

A Hall element is placed on the shaded part in the figure.

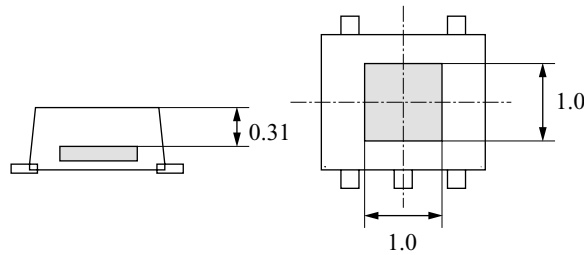

- Magneto-electro conversion characteristics

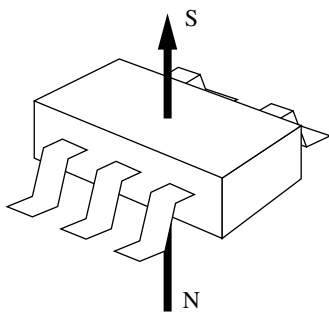

Direction of applied magnetic field

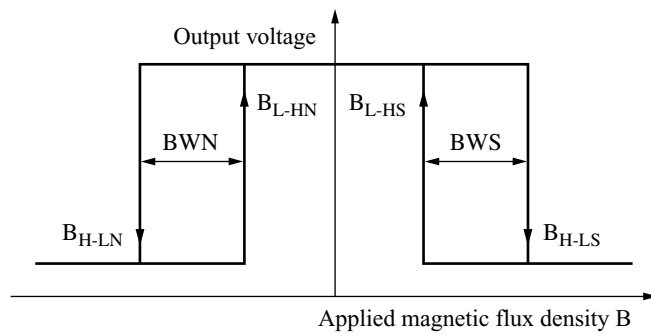

Operating magnetic flux density

- Power dissipation of package MINI-5DA

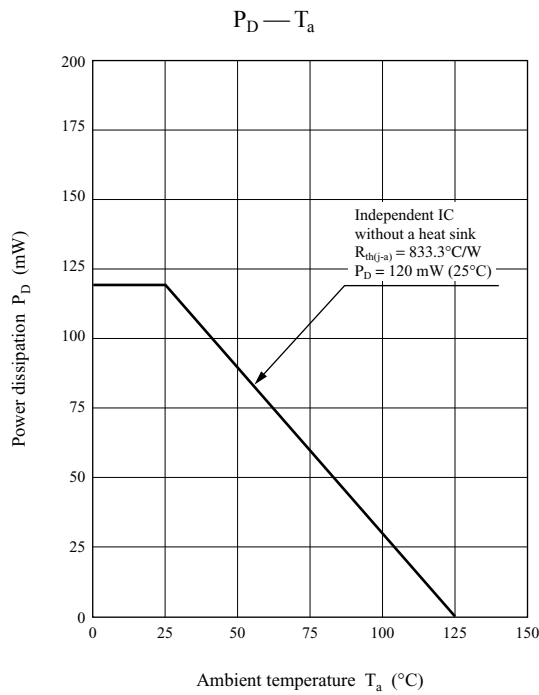

■ Technical Data (continued)

• Main characteristics

Operating magnetic flux density — Supply voltage

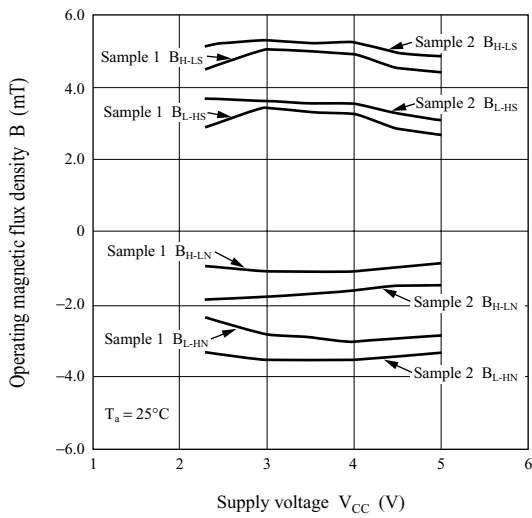

Operating magnetic flux density — Ambient temperature

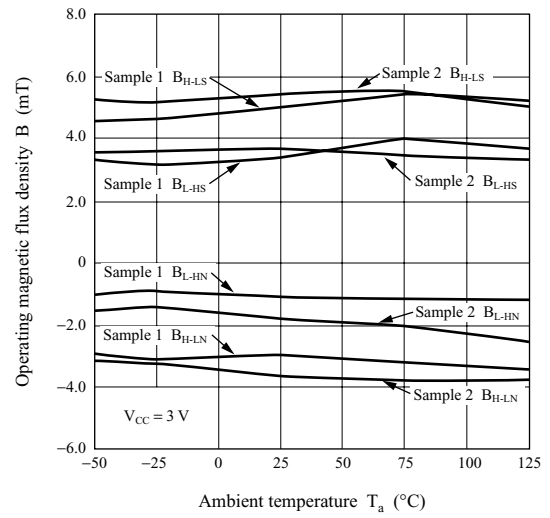

Hysteresis width — Supply voltage

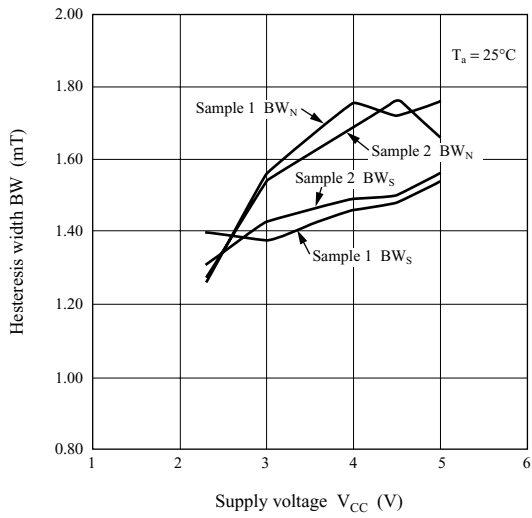

Supply current — Supply voltage

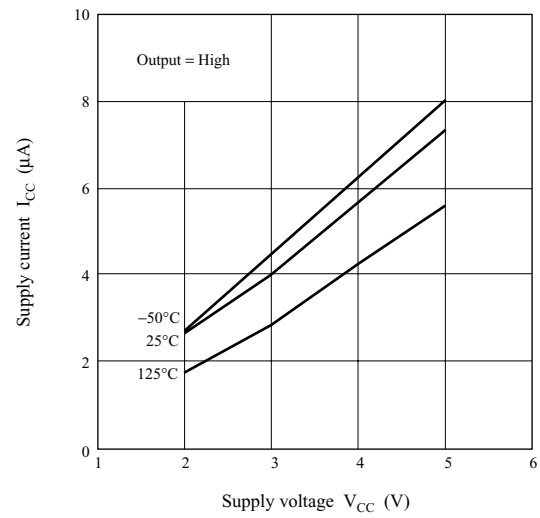

Low-level output voltage — Supply voltage

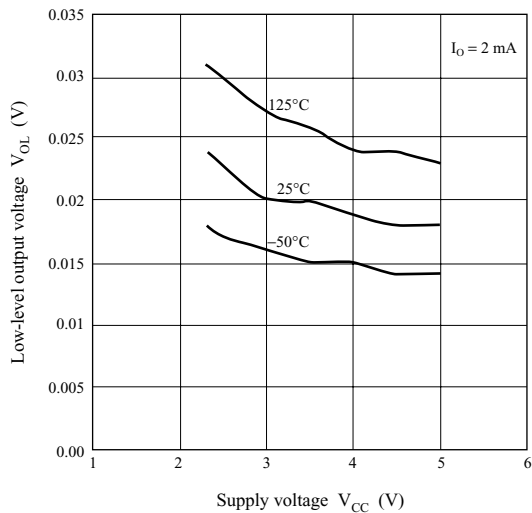

Δ high-level output voltage — Supply voltage

