

# MA2J728

## Silicon epitaxial planar type

For super-high speed switching circuit

For wave detection circuit

### ■ Features

- Sealed in the S-mini (2-pin) mold and super small type
- Low forward rise voltage ( $V_F$ ) and satisfactory wave detection efficiency ( $\eta$ )
- Extremely low reverse current  $I_R$
- Small temperature coefficient of forward characteristic

### ■ Absolute Maximum Ratings $T_a = 25^\circ\text{C}$

Parameter	Symbol	Rating	Unit
Reverse voltage (DC)	$V_R$	30	V
Peak reverse voltage	$V_{RM}$	30	V
Peak forward current	$I_{FM}$	150	mA
Forward current (DC)	$I_F$	30	mA
Junction temperature	$T_j$	125	$^\circ\text{C}$
Storage temperature	$T_{stg}$	-55 to +125	$^\circ\text{C}$

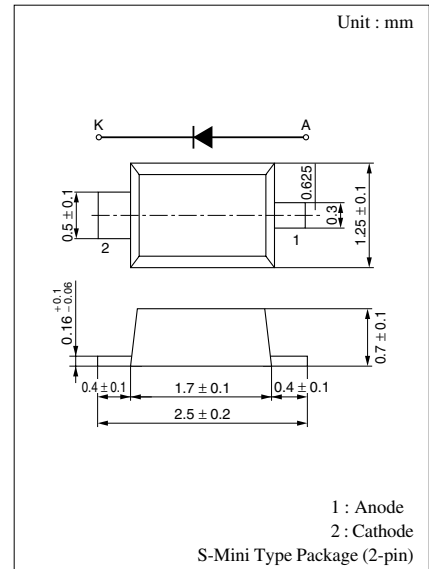

Marking Symbol: 2A

### ■ Electrical Characteristics $T_a = 25^\circ\text{C}$

Parameter	Symbol	Conditions	Min	Typ	Max	Unit
Reverse current (DC)	$I_R$	$V_R = 30\text{ V}$			300	nA
Forward voltage (DC)	$V_{F1}$	$I_F = 1\text{ mA}$			0.4	V
	$V_{F2}$	$I_F = 30\text{ mA}$			1.0	V
Terminal capacitance	$C_t$	$V_R = 1\text{ V}, f = 1\text{ MHz}$		1.5		pF
Reverse recovery time*	$t_{rr}$	$I_F = I_R = 10\text{ mA}$ $I_{rr} = 1\text{ mA}, R_L = 100\ \Omega$		1.0		ns
Detection efficiency	$\eta$	$V_{in} = 3\text{ V}_{(peak)}, f = 30\text{ MHz}$ $R_L = 3.9\text{ k}\Omega, C_L = 10\text{ pF}$		65		%

Note) 1. Schottky barrier diode is sensitive to electric shock (static electricity, etc.). Due attention must be paid on the charge of a human body and the leakage of current from the operating equipment

2. Rated input/output frequency: 2 000 MHz

3. \*:  $t_{rr}$  measuring instrument

