



T-27-09



2067

NPN Epitaxial Planar
Silicon Composite Transistor

Low-Frequency General-Purpose Amp, Differential Amp Applications

©3110

Features

- Composite type with 2 transistors contained in the CP package currently in use, improving the mounting efficiency greatly.
- The FC102 is formed with two chips, being equivalent to the 2SC4211, placed in one package.
- Excellent in thermal equilibrium and pair capability and suitable for use in differential amp.

Absolute Maximum Ratings at Ta = 25°C

		unit
Collector to Base Voltage	V _{CB0}	55 V
Collector to Emitter Voltage	V _{CE0}	50 V
Emitter to Base Voltage	V _{EBO}	6 V
Collector Current	I _C	150 mA
Peak Collector Current	i _{cp}	300 mA
Base Current	I _B	30 mA
Collector Dissipation	P _C	200 mW
Total Power Dissipation	P _T	300 mW
Junction Temperature	T _j	150 °C
Storage Temperature	T _{stg}	-55 to +150 °C

Electrical Characteristics at Ta = 25°C

		min	typ	max	unit
Collector Cutoff Current	I _{CB0}			0.1	μA
Emitter Cutoff Current	I _{EBO}			0.1	μA
DC Current Gain	h _{FE}		160	600	
DC Current Gain Ratio	h _{FE} (small/large)	0.8	0.98		
Base to Emitter Voltage Drop	V _{BE} (large-small)		1.0	15	mV
Gain-Bandwidth Product	f _T		200		MHz
Output Capacitance	C _{ob}		1.7		pF
C-E Saturation Voltage	V _{CE(sat)}		0.08	0.4	V
B-E Saturation Voltage	V _{BE(sat)}		0.8	1.0	V
C-B Breakdown Voltage	V _{(BR)CBO}		55		V
C-E Breakdown Voltage	V _{(BR)CEO}		50		V
E-B Breakdown Voltage	V _{(BR)EBO}		6		V
Turn-ON Time	t _{on}		0.15		μs
Storage Time	t _{stg}		0.75		μs
Fall Time	t _f		0.20		μs

Note) The specifications shown above are for each individual transistor.
Marking : 102

Switching Time Test Circuit

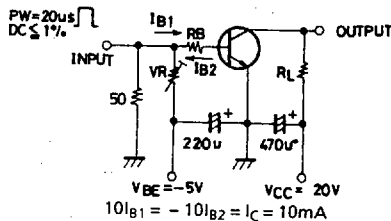

Electrical Connection

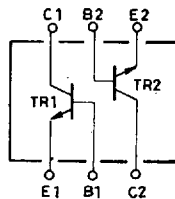

**Case Outline 2067
(unit : mm)**

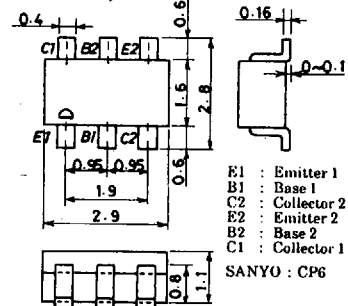

6299MO,TS No.3110-1/3

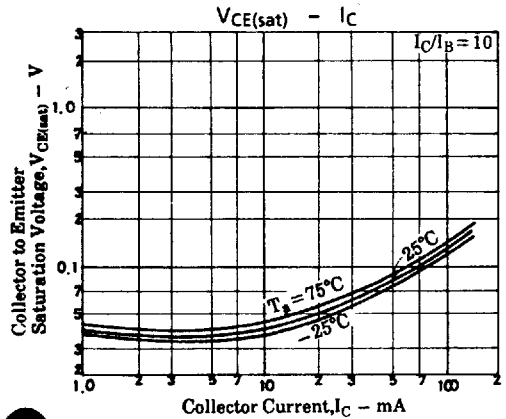
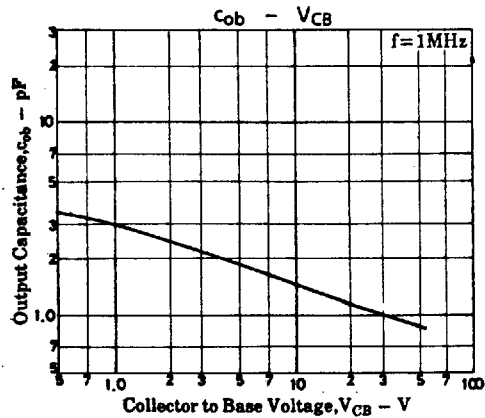
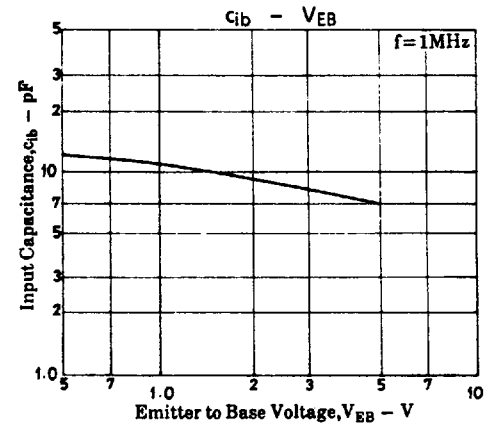
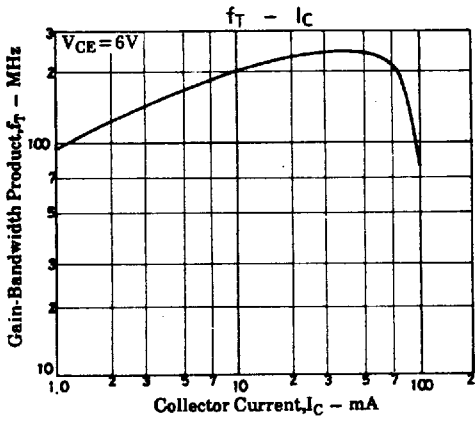
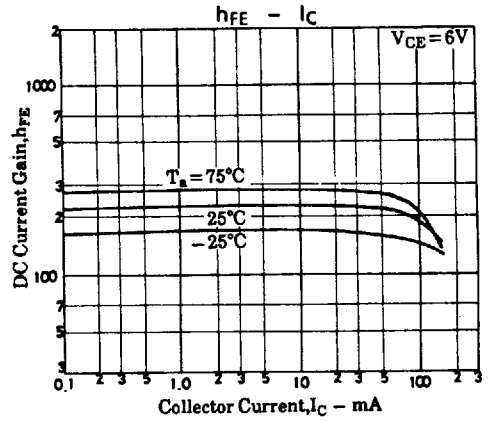
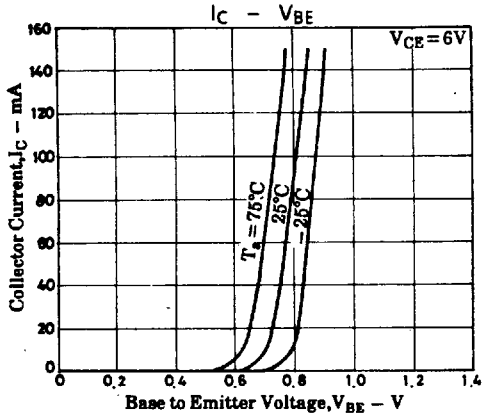
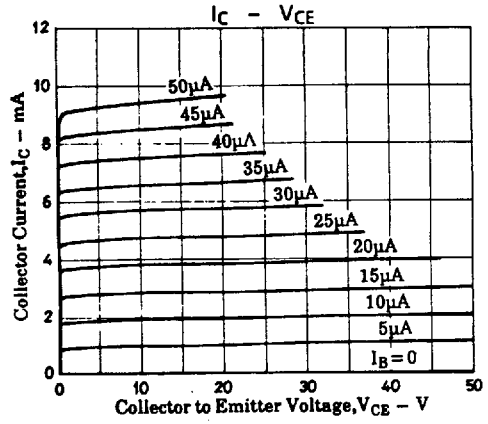
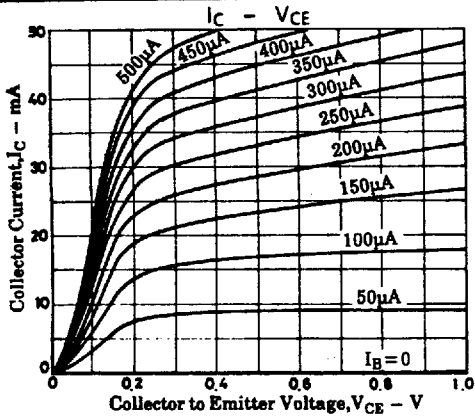

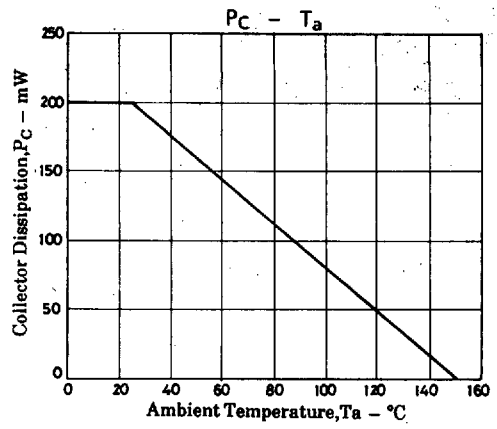
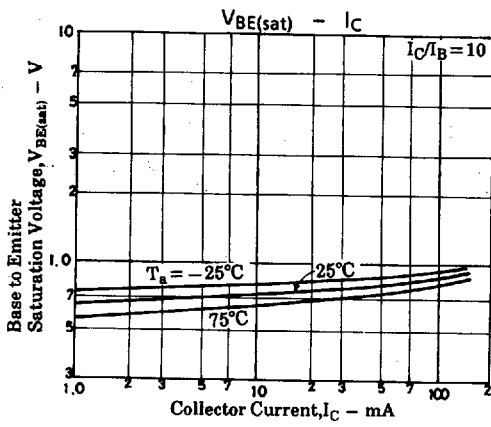

T-91-20

CASE OUTLINES OF SURFACE MOUNT TRANSISTORS

- All of Sanyo surface mount transistor case outlines are illustrated below.
- All dimensions are in mm, and dimensions which are not followed by min. or max. are represented by typical values.
- No marking is indicated.

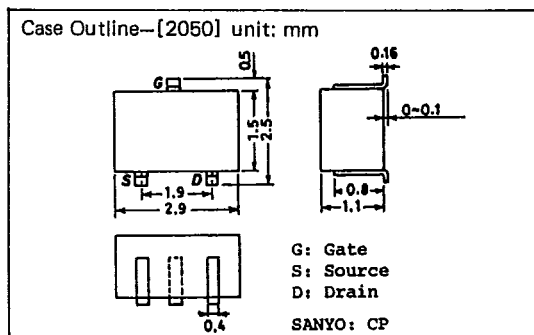
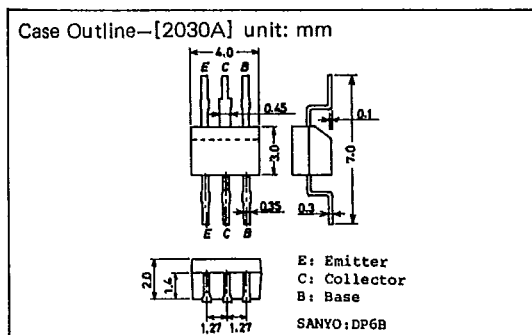
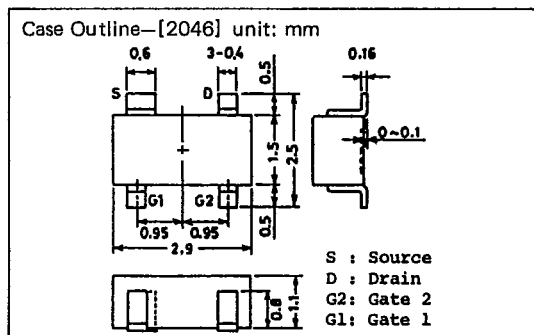
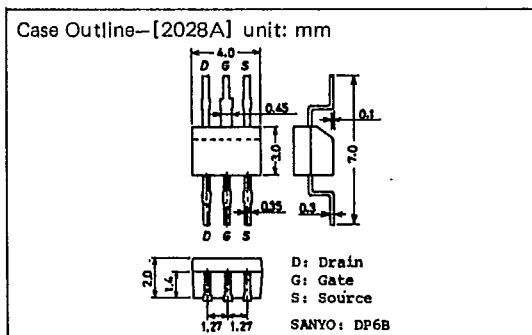
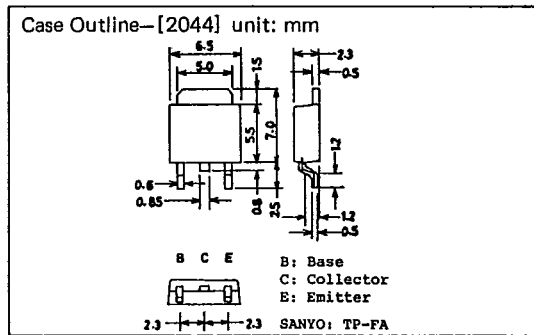
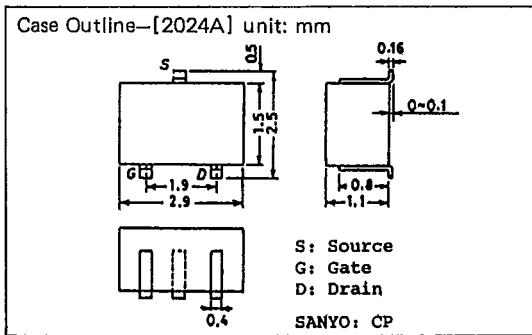
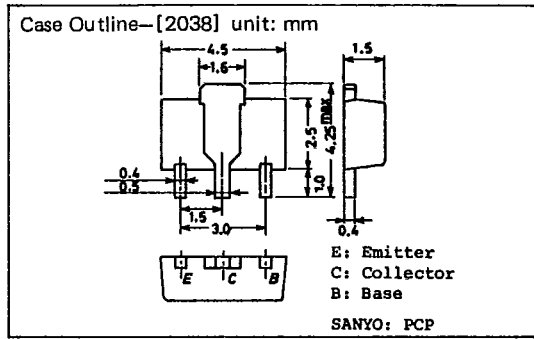
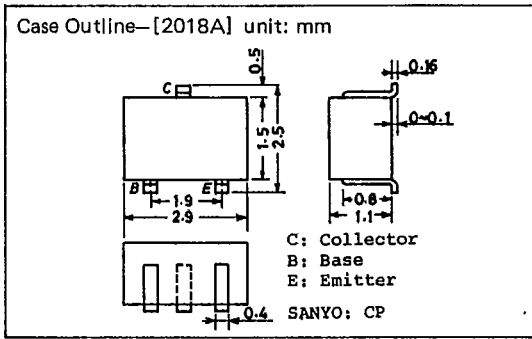

T-91-20

Case Outline—[2057] unit: mm

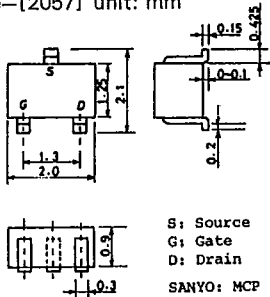

Case Outline—[2066] unit: mm

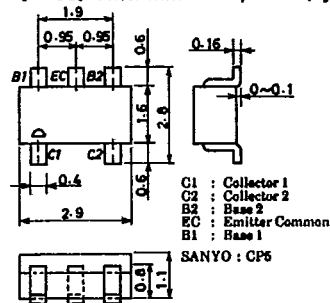

Case Outline—[2058] unit: mm

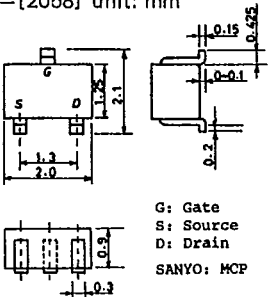

Case Outline—[2067] unit: mm

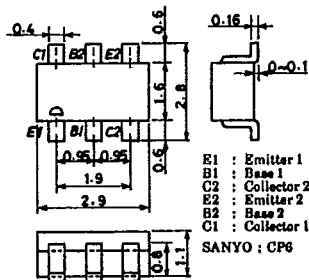

Case Outline—[2059] unit: mm

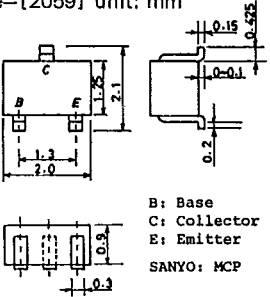

Case Outline—[2068] unit: mm

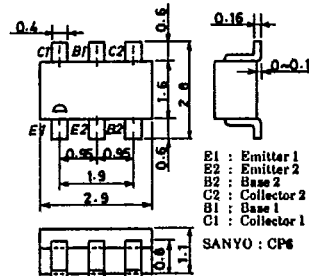

Case Outline—[2062] unit: mm

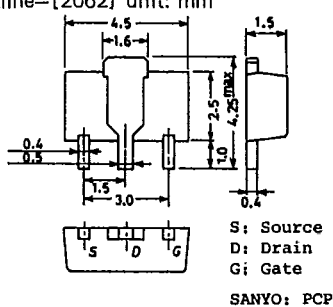

Case Outline—[2069] unit: mm

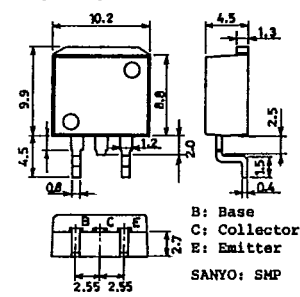

Case Outline—[2065] unit: mm

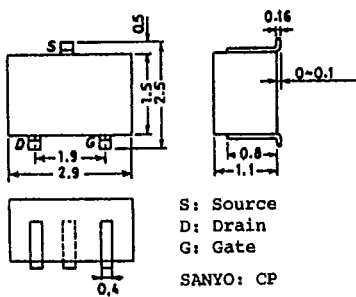

Case Outline—[2070] unit: mm

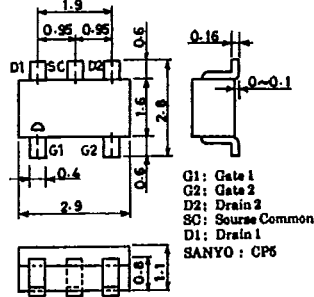

T-9120

