

#### FEATURES

- Small size: see dimensions
- Metal shielding on inner chip
- No adjustment required
- Tape and reel packaging
- Reflow solderable
- Frequency request flexibility
- Frequency range from 200MHz to 2.5GHz

#### LFSN20N TYPE

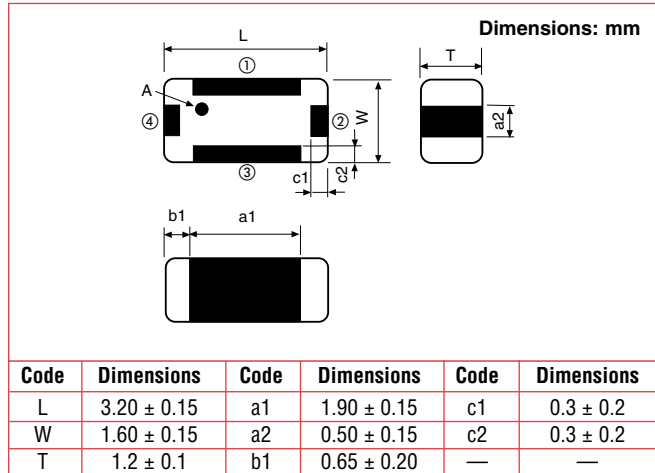

#### TERMINALS: LFSN20N TYPE

Terminal No.	Terminal Name	Terminal No.	Terminal Name
①	GROUND	③	GROUND
②	OUT	④	IN

Terminal of "NC" should be fixed to the no connected pattern.

#### LFSN25N1 TYPE

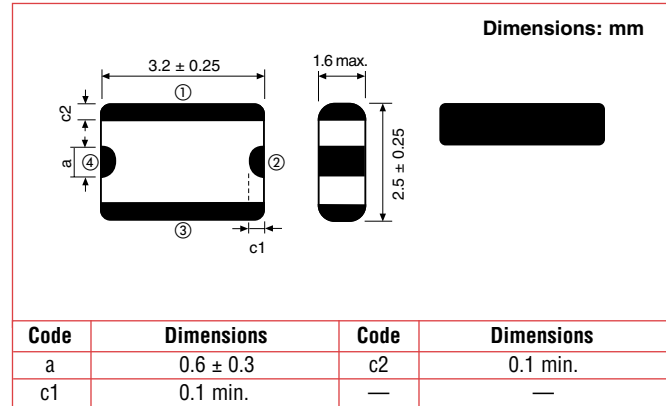

#### TERMINALS: LFSN25N1 TYPE

Terminal No.	Terminal Name
①	GROUND
②	OUT
③	GROUND
④	IN

#### LFA30 TYPE

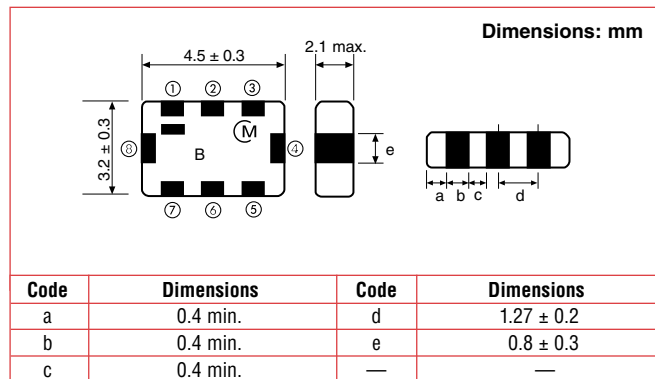

#### TERMINALS: LFA30 TYPE

Terminal No.	Terminal Name	Terminal No.	Terminal Name
①	NC	⑤	NC
②	GROUND	⑥	GROUND
③	NC	⑦	NC
④	OUT	⑧	IN

Terminal of "NC" should be fixed to non-conductive path.

#### LFSN30N1 TYPE

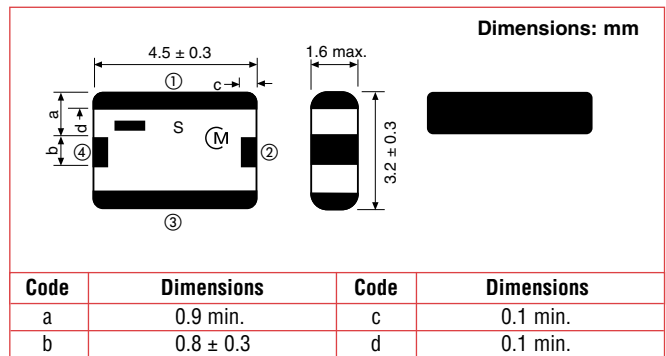

#### TERMINALS: LFSN30N1 TYPE

Terminal No.	Terminal Name
①	GROUND
②	OUT
③	GROUND
④	IN

**LFB30N1 TYPE**

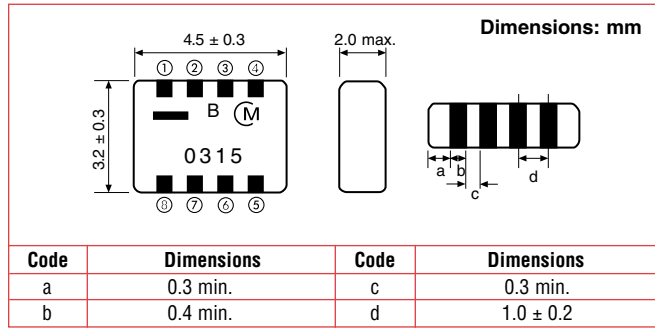

**TERMINALS: LFB30N1 TYPE**

Terminal No.	Terminal Name	Terminal No.	Terminal Name
①	IN	⑤	GROUND
②	NC2	⑥	NC1
③	NC2	⑦	NC1
④	OUT	⑧	GROUND

Terminal of "NC1" should be fixed to the no connected pattern.  
Terminal of "NC2" should not be fixed any pattern.

**LFSB25N1 TYPE**

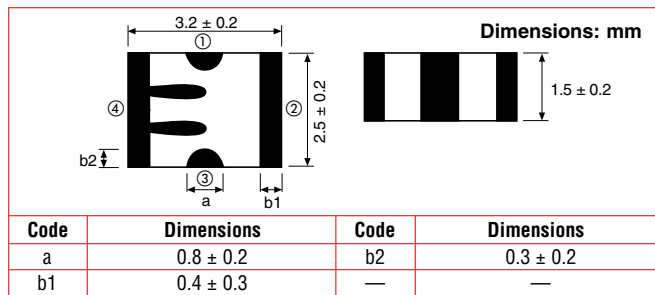

**TERMINALS: LFSB25N1 TYPE**

Terminal No.	Terminal Name	Terminal No.	Terminal Name
①	IN	③	OUT
②	GROUND	④	GROUND

**LFSC25 TYPE**

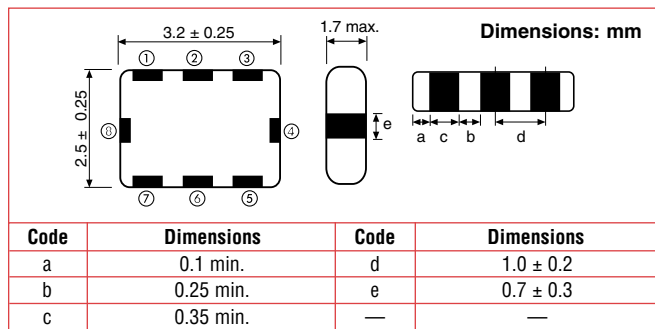

**TERMINALS: LFSC25 TYPE**

Terminal No.	Terminal Name	Terminal No.	Terminal Name
①	NC	⑤	NC
②	GROUND	⑥	GROUND
③	NC	⑦	NC
④	OUT	⑧	IN

Terminal of "NC" should be fixed to the no connected pattern.

**LFSA25-1 TYPE**

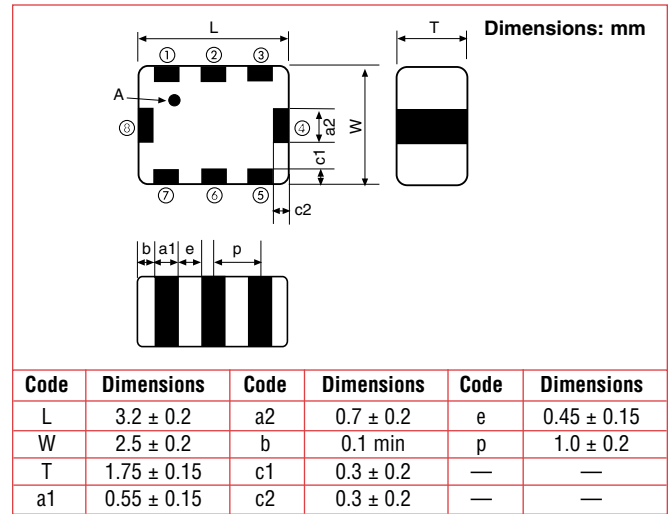

**TERMINALS: LFSA25-1 TYPE**

Terminal No.	Terminal Name	Terminal No.	Terminal Name
①	NC	⑤	NC
②	GROUND	⑥	GROUND
③	NC	⑦	NC
④	OUT	⑧	IN

Terminal of "NC" should be fixed to the no connected pattern.

**LFSG20N TYPE**

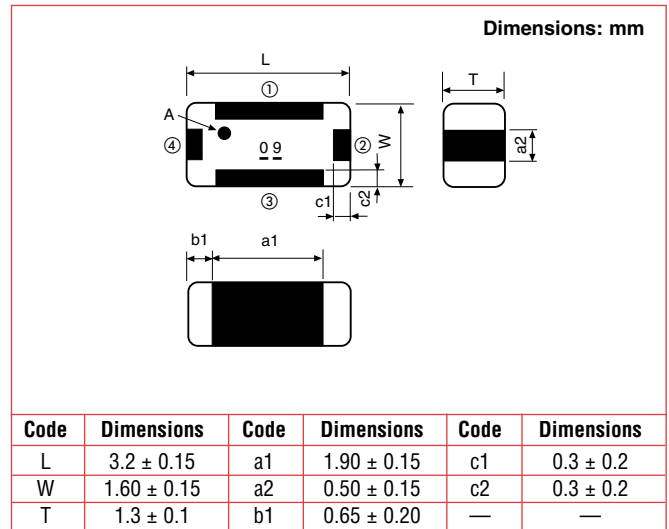

**TERMINALS: LFSG20N TYPE**

Terminal No.	Terminal Name	Terminal No.	Terminal Name
①	GROUND	③	GROUND
②	OUT	④	IN

LFSG, LFSL, LFSP, & LFSN Series

**LFSG25N TYPE**

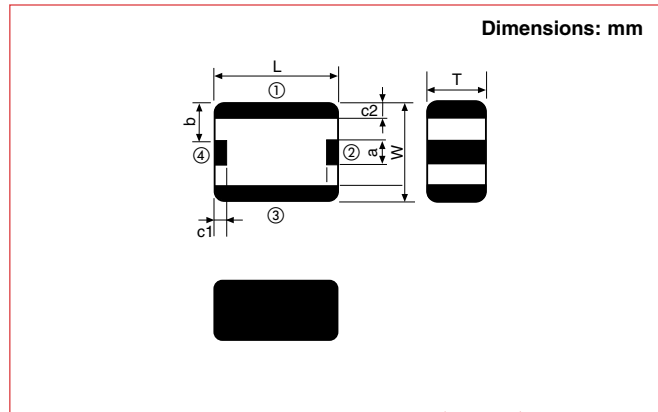

Code	Dimensions	Code	Dimensions	Code	Dimensions
L	$3.2 \pm 0.2$	a	$0.6 \pm 0.2$	c2	$0.4 \pm 0.2$
W	$2.5 \pm 0.2$	b	$0.95 \pm 0.15$	—	—
T	$1.75 \pm 0.15$	c1	$0.30 \pm 0.15$	—	—

**TERMINALS: LFSG25N TYPE**

Terminal No.	Terminal Name	Terminal No.	Terminal Name
①	GROUND	③	GROUND
②	OUT	④	IN

**LFSP20N TYPE**

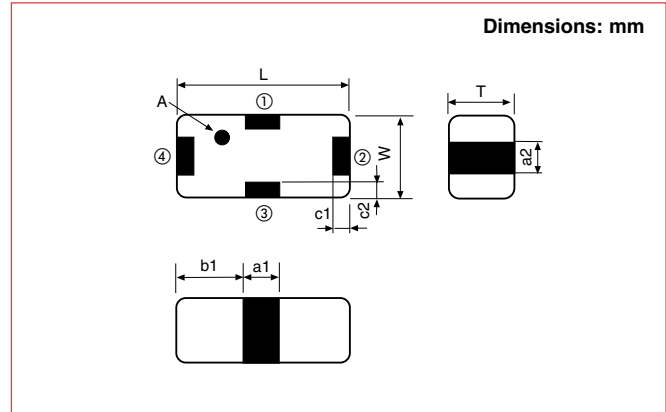

Code	Dimensions	Code	Dimensions	Code	Dimensions
L	$3.20 \pm 0.15$	a1	$0.50 \pm 0.15$	c1	$0.25 \pm 0.15$
W	$1.60 \pm 0.15$	a2	$0.95 \pm 0.15$	c2	$0.25 \pm 0.15$
T	$1.3 \pm 0.1$	b1	$1.35 \pm 0.20$	—	—

**TERMINALS: LFSP20N TYPE**

Terminal No.	Terminal Name	Terminal No.	Terminal Name
①	IN	③	OUT
②	GROUND	④	GROUND

**LFSL20N TYPE**

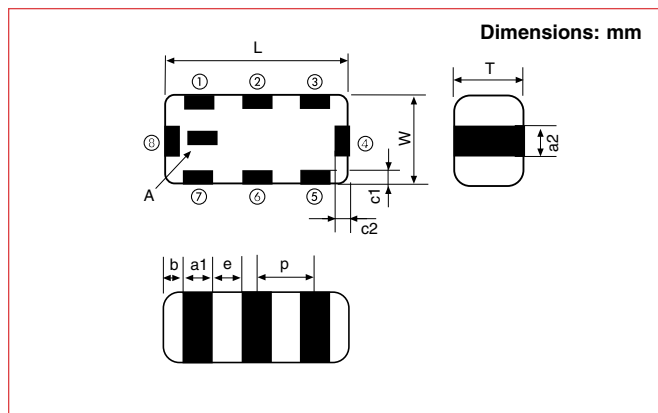

Code	Dimensions	Code	Dimensions	Code	Dimensions
L	$3.2 \pm 0.15$	a1	$0.5 \pm 0.1$	e	$0.45 \pm 0.15$
W	$1.60 \pm 0.15$	b	$0.35 \pm 0.15$	c2	$0.3 \pm 0.2$
T	$1.1 \pm 0.1$	c1	$0.25 \pm 0.1/-0.15$	—	—
a1	$0.5 \pm 0.1$	c2	$0.25 \pm 0.1/-0.15$	—	—

**TERMINALS: LFSL20N TYPE**

Terminal No.	Terminal Name	Terminal No.	Terminal Name
①	NC	⑤	NC
②	GROUND	⑥	GROUND
③	NC	⑦	NC
④	OUT	⑧	IN

Terminal of "NC" should be fixed to the no connected pattern.

**LFSN25N TYPE**

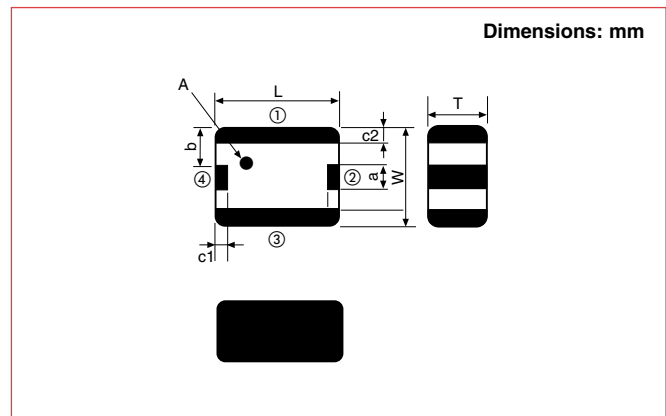

Code	Dimensions	Code	Dimensions	Code	Dimensions
L	$3.2 \pm 0.2$	a	$0.6 \pm 0.2$	c2	$0.4 \pm 0.2$
W	$2.5 \pm 0.2$	b	$0.95 \pm 0.15$	—	—
T	$1.5 \pm 0.1$	c1	$0.30 \pm 0.15$	—	—

**TERMINALS: LFSN25N TYPE**

Terminal No.	Terminal Name	Terminal No.	Terminal Name
①	GROUND	③	GROUND
②	OUT	④	IN

Mark A = Directional Input Mark

**SPECIFICATIONS**

Application	Part Number	Frequency Range (MHz)	Insertion Loss		VSWR	Attenuation (dBmin.)	Ripple (dB)
			at 25°C (dBmax.)	at -30 ± 85°C (dBmax.)			
E-AMPS	LFA30-11B0836B025	836.5 ± 12.5	4.20	4.90	2.3 max.	9 at 869-894MHz	1.5
	LFA30-12B0836B	836.5 ± 12.5	3.00	3.50	2.2 max	19.5 at fo±77.5MHz, 17.5 at 954-980MHz, 16.0 at 1039-1110MHz	1.00
	LFA30-12B0836B025	836.5 ± 12.5	3.00	3.70	2.2 max.	20 at 914-939MHz	1
	LFA30-11B0881B025	881.5 ± 12.5	4.00	4.70	2.2 max.	7 at 824-849MHz, 9 at 914-939MHz	1.5
	LFA30-12B0881B025	881.5 ± 12.5	3.00	3.70	2.2 max.	20 at 804MHz, 20 at 959MHz	1
	LFA30-11B0881B	881.5 ± 12.5	4.80	5.30	2.2 max	11 at 824-837MHz, 11 at 933-959MHz	2.00
	LFA30-12B0881B	881.5 ± 12.5	3.00	3.50	2.2 max	16 at 780MHz	1.50
	LFA30-11B0926B025	926.5 ± 12.5	3.80	4.50	2.2 max.	7 at 869-894MHz	1.5
	LFA30-12B0964B025	964.5 ± 12.5	3.00	3.70	2.2 max.	18 at 869-894MHz	1
	LFA30-12B0967B	967.0 ± 13.0	3.20	3.70	2.2 max	14 at 869-894MHz, 16 at 1039.7-1064.7MHz, 25 at 869MHz	1.20
LMR	LFA30-11B0815B020	815 ± 10	4.00	4.70	2.2 max.	10 at 850-870MHz	1.5
	LFA30-11B0815B	815.5 ± 9.50	4.00	4.50	2.2 max	10 at 851-870	1.50
	LFA30-12B0860B020	860 ± 10	3.00	3.70	2.2 max.	20 at 760-780MHz	1.5
PCS	LFA30-12B0739B	739.15 ± 19.0	3.00	3.50	2.2 max	19 at 832-870MHz, 25 at 887-925MHz, 20 at 2 x fo MHz, 10 at 3 x fo MHz	1.00
	LFA30-12B0741B	741.5 ± 19.5	3.50	4.00	2.2 max	20 at 612-650MHz, 20 at 832-870MHz	1.50
	LFSN30N15C1880B	1880 ± 30	2.20	2.50	2.0 max.	40 at 1400MHz, 40 at 1640MHz	1
	LFSG25N15C1960B	1960.0 ± 30.0	2.50	2.80	2.0 max	35 at 2190-2250MHz	1.00
	LFSN30N15C1960B	1960 ± 30	2.50	2.80	2.0 max.	39 at 1520MHz, 16 at 1740MHz	1
	LFSN30N15D1960B	1960.0 ± 30.0	2.50	2.80	2.0 max	30 at 2190MHz, 30 at 2190-2250MHz	1.00
ISM2.4	LFSG20N27C2450B	2450.0 ± 50.0	2.00	2.30	2.0 max	38 at 902-928MHz, 15 at 2100-2200MHz, 38 at 4800-5000MHz	0.80
	LFSP20N28B2450B	2450.0 ± 50.0	1.40	1.70	2.0 max	20 at 902-928MHz, 33 at 1500-1550MHz, 6 at 2150-2200MHz, 17 at 4800-5000MHz	0.60
ISM5.8	LFSN20N19B5800B	5800.0 ± 50.0	2.00	2.30	2.0 max	35 at 2000MHz, 30 at 3000MHz, 25 at 8500-9000MHz	1.50
	LFSN20N19B5820	5820.0 ± 30.0	2.00	2.30	2.2 max	35 at 200MHz, 30 at 3000MHz, 25 at 8500-9000MHz	1.50
	LFSN20N19B5830B	5830.0 ± 9.0	1.50	1.80	2.31 max	25 at 2 x fo MHz	1.00
ISM915	LFA30-12B0915B026	915 ± 13	2.80	3.50	2.2 max.	20 at 837.5MHz, 20 at 992.5MHz	1
	LFA30-12B0915B	915.0 ± 13.0	3.00	3.50	2.2 max	20 at fo ± 13MHz	1.00
	LFSC25N28B0915B	915.0 ± 13.0	1.10	1.60	2.0 max	20 at 2 x fo MHz, 37 at 3 x fo MHz	0.50
	LFSL20N19B0915B	915.0 ± 13.0	1.30	1.80	2.0 max	12 at 615MHz, 39 at 1804-1856MHz, 35 at 2400-2500MHz, 35 at 2706-2784MHz	0.70
ISM2.4	LFSN25N16C2450	2450.0 ± 50.0	2.50	2.80	2.0 max.	40 at 1950MHz, 16 at 2200MHz, 9.5 at 2700MHz, 24 at 4900MHz, 24 at 2950 MHz	1.50
RKE	LFSC25N12B0315B	315 ± 0	3.50	4.00	2.2 max.	30 at 235MHz, 30 at 395MHz	—
	LFSC25N13B0315B	315 ± 0.5	3.50	4.00	2.0 max.	45 at 180MHz, 29 at 470MHz	0.5
	LFSC25N12B0433B	433.9 ± 0	3.50	4.00	2.2 max.	28 at 353.9MHz, 28 at 513.9MHz	—
PAGER	LFB30N12B0280B008	280 ± 4	4.00	4.70	—	24 at 235MHz	1
	LFB30N12B0284B008	284 ± 4	4.00	4.70	—	24 at 239MHz	1
	LFB30N12B0325B008	325 ± 4	3.80	4.50	—	28 at 265MHz	1.5
	LFB30N12B0435B010	435 ± 5	3.80	4.50	2.2 max.	27 at 368MHz, 27 at 502MHz	1
	LFB30N12B0445B010	445 ± 5	3.80	4.50	2.2 max.	27 at 378MHz, 27 at 512MHz	1
PDC800	LFSC25N26B0848B	848.5 ± 37.5	1.5	2	2.0 max	25 at 550-583MHz, 17 at 610-625MHz, 3 at 680-713MHz	0.70
	LFSL20N16B0847B	847.5 ± 37.5	1.40	1.90	2.0 max	25 at 550-583MHz, 25 at 610-825MHz	0.70
PDC1500	LFA30-12B1489B	1489.0 ± 12.0	1.80	2.30	2.2 max	29 at fo - (273-248) MHz	0.70
	LFSG20N16B1489B	1489.0 ± 12.0	1.30	1.60	2.0 max	25 at 1735-1760MHz, 12 at 2 x fo MHz, 12 at 3 x fo MHz	0.30

Power Capacity: 500mWatt

# MULTILAYER DEVICES

## LC FILTERS—BAND PASS, CHIP MULTILAYER

### LFA30, LFB30, LFSC25 & LFSN30 Series (continued)

#### SPECIFICATIONS

Application	Part Number	Frequency Range (MHz)	Insertion Loss		VSWR	Attenuation (dBmin.)	Ripple (dB)
			at 25°C (dBmax.)	at -30 ± 85°C (dBmax.)			
PHS	LFSB25N15B1906B	1906.5 ± 14.5	1.00	1.20	2.0 max	35 at 1395-1454MHz, 20 at 1644-1687MHz, 15 at 3786-3840MHz	0.30
	LFSG20N16B1906B	1906.5+24.5/-13	2.50	2.80	2.0 max	40 at 1397.5-1422.85MHz, 35 at 1645.5-1671.3MHz, 20 at 3291-3342.6MHz	0.70
	LFSN25N15C1906B	1906.5 ± 13.5	2.00	2.30	2.0 max	34 at 1655-1680MHz, 39 at 1406.5-1440MHz, 6 at 2135-2160MHz	0.80
	LFSN25N15D1906B	1906.5 ± 13.5	3.00	3.30	2.0 max	35 at 1653-1680MHz, 40 at 1413-1440MHz, 30 at 2133-2160MHz	0.80
	LFSN30N15C1906B	1906.5 ± 13.5	2.20	2.50	2.0 max	40 at fo - (226.5 - 253.5) MHz, 40 at fo - (466.5-502.0) MHz	0.80
	LFSN30N15D1906B	1906.5 ± 13.5	2.50	2.80	2.0 max	29 at 1649.5-1658.5MHz, 40 at 1405.5-1453.5MHz, 30 at 3299-3373MHz	1.00
	LFSN30N18C1906B	1906.5 ± 13.5	1.90	2.20	2.0 max	26 at 1646-1680MHz, 55 at 1389-1440MHz, 14 at 2133-2157MHz	0.80
	LFSP20N28B1906B	1906.5 ± 13.5	1.00	1.30	2.0 max	40 at 1405-1440MHz, 12 at 1649-1680MHz, 24 at 3786-3840MHz	0.50
	LFSB25N15B1662B	1662 ± 12.5	2.00	2.20	2.0 max.	27 at 1895-1918MHz, 20 at 2 x fo MHz, 20 at 3 x fo MHz	0.5
JAPAN ANALOG	LFA30-12B0865B010	865 ± 5	3.00	3.70	2.2 max.	20 at 787.5MHz, 20 at 942.5MHz	1
GSM	LFA30-12B0897B035	897.5 ± 17.5	3.00	3.70	2.2 max.	15 at 792-827MHz, 15 at 968-1003MHz	1
	LFSC25N25B0897B	897.5 ± 17.5	1.80	2.30	1.92 max	25 at 1285-1320MHz	0.70
	LFA30-12B0902B025	902.5 ± 12.5	3.00	3.70	2.2 max.	18 at 980-1005MHz	1.5
	LFA30-12B0942B035	942.5 ± 17.5	3.50	4.20	2.2 max.	16 at 865MHz, 16 at 1020MHz	1.5
	LFSC25N26B0942B	942.5 ± 17.5	1.80	2.30	2.0 max	18 at 1167.5 ± 175MHz, 27 at 1392.5 ± 17.5MHz	0.80
	LFA30-12B0947B025	947.5 ± 12.5	3.00	3.70	2.2 max.	20 at 870MHz, 20 at 1025MHz	1.5
DCS1800	LFSN25N15C1747B	1747.5 ± 37.5	2.50	2.80	2.2 max	20 at DC-1350MHz, 30 at 1350-1425MHz, 25 at 2300-5000MHz	1.00
	LSN30N15C1747B	1747.5 ± 37.5	2.00	2.30	2.0 max	20 at DC-1350MHz, 30 at 1350-1425MHz, 25 at 2300-5000MHz	1.00
	LFSN25N18C1842B	1842.5 ± 37.5	2.50	2.80	2.1 max	40 at 1450-1480MHz, 13 at 1480-1665MHz, 8 at 2050-2410MHz	1.00
	LFSN30N18C1842B	1842.5 ± 37.5	2.00	2.30	2.0 max	15 at 1590-1665MHz, 54 at 1375-1450MHz, 17 at 2100-2150MHz	1.00
DECT	LFSB25N15B1890B	1890 ± 10	1.20	1.40	2.0 max.	20 at 15655-1675MHz, 20 at 2 x fo MHz, 20 at 3 x fo MHz	0.3
	LFSN30N15C1890B	1890 ± 10	2.00	2.30	2.0 max.	37 at 1670MHz, 20 at 2 x fo MHz, 14 at 3 x fo MHz	0.8
	LFSN30N15D1890B	1890.0 ± 10.0	2.50	2.80	2.0 max	36 at 1655-1678MHz, 4 at 1767-1788MHz, 35 at 3760-3800MHz	1.00

Power Capacity: 500mWatt

#### PART NUMBERING SYSTEM

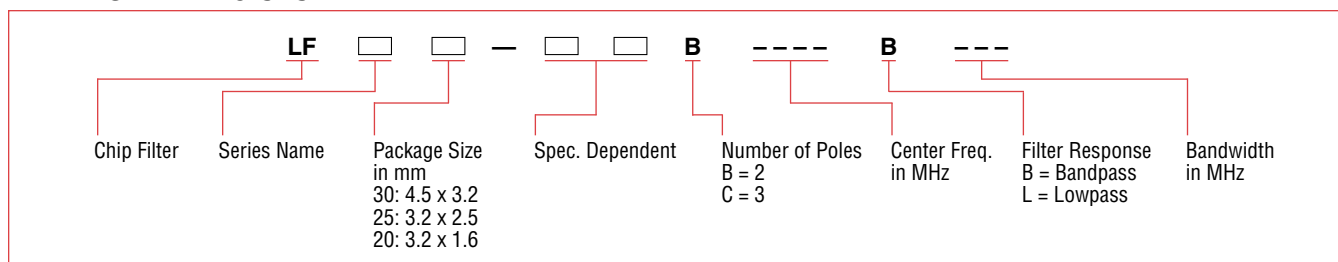

LAND PATTERNS FOR PCB MOUNTING

DIMENSIONS: mm

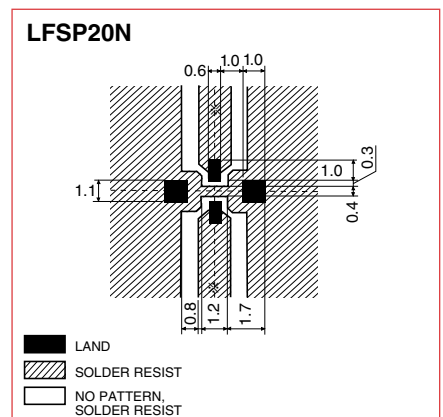
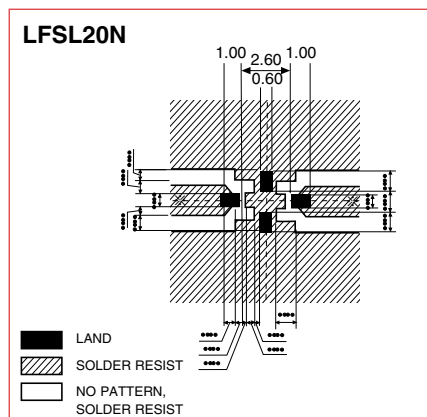
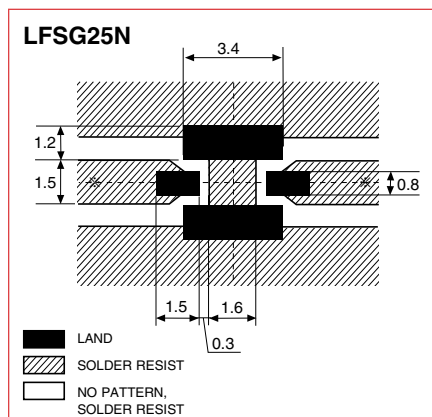
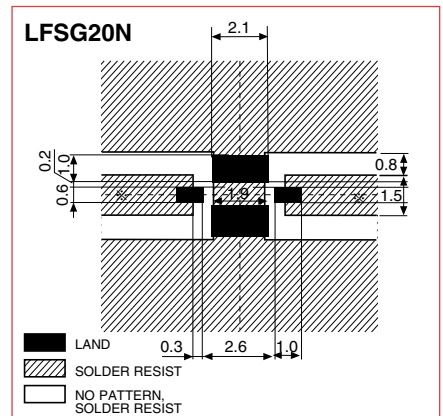
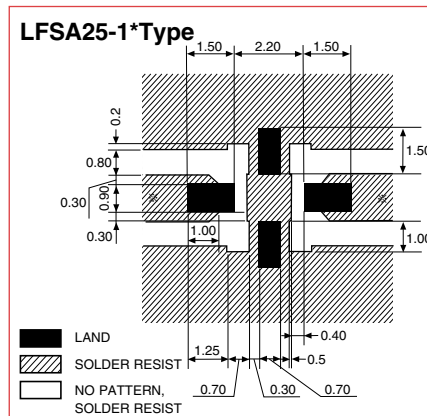
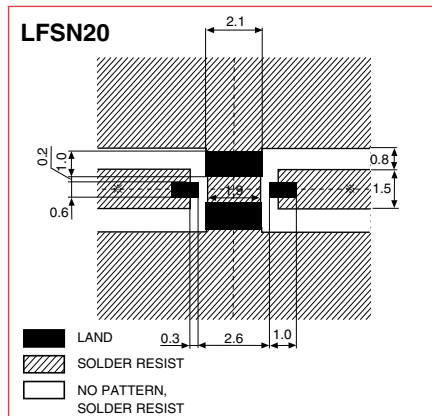
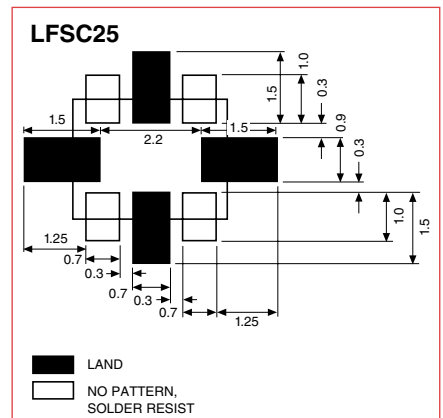
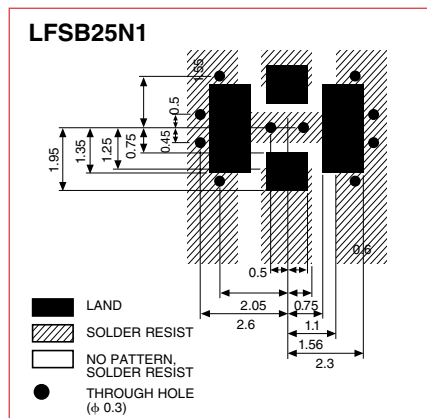
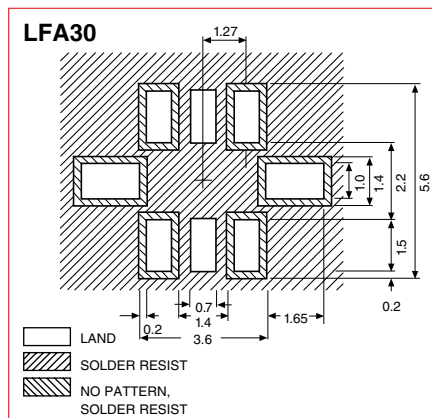
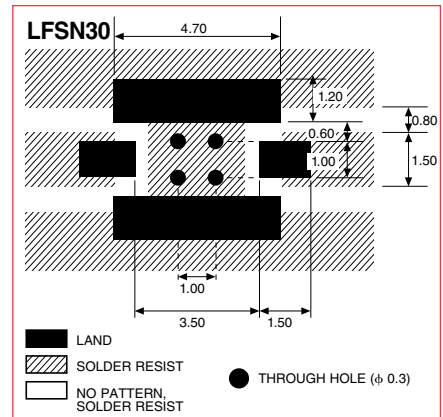
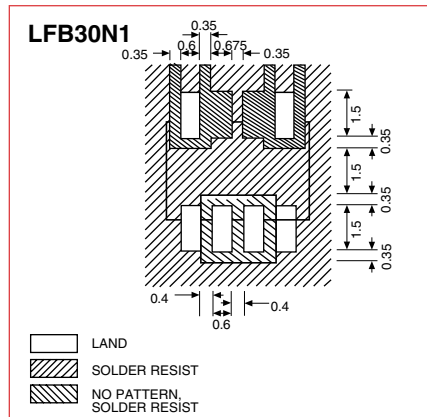
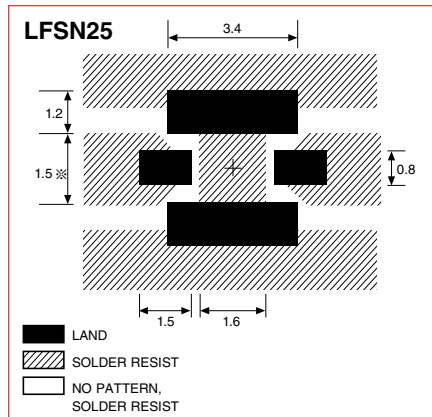

\* Line width to be designed to match 50Ω characteristic impedance, depending on PCB material and thickness.