

OVERVIEW

The SM8146AD1 is a dedicated EL (Electro Luminescence) driver IC, capable of driving EL sheet up to 30cm² in size. The EL drive circuit uses a technique that generates smooth sine wave EL drive waveforms without an output resistor, which has the advantage of preventing EL sheet audible noise, eliminating the need for additional peripheral components and a corresponding drop in power efficiency. Also, the EL drive voltage is constant-voltage controlled and is unaffected by supply voltage fluctuations, so that there are no EL brightness variations due to supply voltage changes. A dimming function is available under direct control from a microcontroller. The logic HIGH-level input voltage range (ENA, DIM pins) starts at 1.4V, allowing the device to be driven directly without external transistors from a Li-ion battery.

FEATURES

- Sine wave EL drive waveforms for low audible noise
- Constant EL drive voltage independent of supply voltage fluctuations
- Separate coil and EL drive frequency adjustment
- Enable function (ENA pin)
- Dimming function (DIM pin)
- Direct control capability using 1.8V system CPU (ENA, DIM pins)
V_{IH} = 1.4V (min, V_{DD} = 2.5 to 5.5V)
- 2.5 to 5.5V supply voltage range
- 170Vp-p (typ) maximum EL drive voltage
- 250Hz (typ) EL drive frequency (R_{OCE} = 200kΩ)
- 0.5mA (typ) operating current
- 1.0μA (max) standby current
- 220μH (typ) recommended inductance
- Package: 10-pin SON

APPLICATIONS

- Cellular phone
- Portable audio equipment
- Handy terminal
- Other portable application

STANDARD CIRCUIT CONFIGURATION

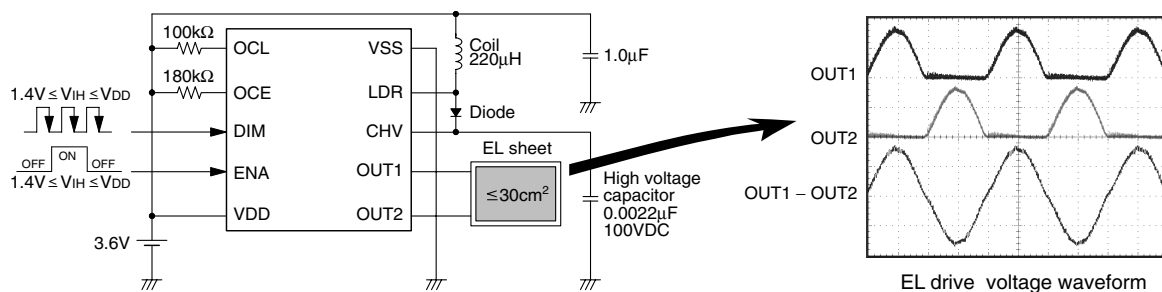

ORDERING INFORMATION

Device	Package
SM8146AD1	10-pin SON

PINOUT

(Top view)

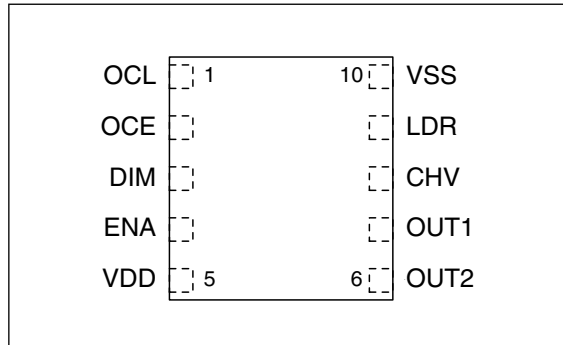

PIN DESCRIPTION

Number	Name	I/O	Function
1	OCL	I	Coil drive oscillator pin (frequency adjusted using an external resistor)
2	OCE	I	EL drive oscillator pin (frequency adjusted using an external resistor)
3	DIM	Ip ¹	Dimming signal input pin (connect to ground when not used)
4	ENA	Ip ¹	Enable signal input pin (HIGH: enable, LOW: disable)
5	VDD	-	Power supply pin
6	OUT2	O	EL drive output pin 2
7	OUT1	O	EL drive output pin 1
8	CHV	I	High-voltage DC pin
9	LDR	O	Coil drive output pin
10	VSS	-	Ground pin

1. Pull-down resistor built-in

BLOCK DIAGRAM

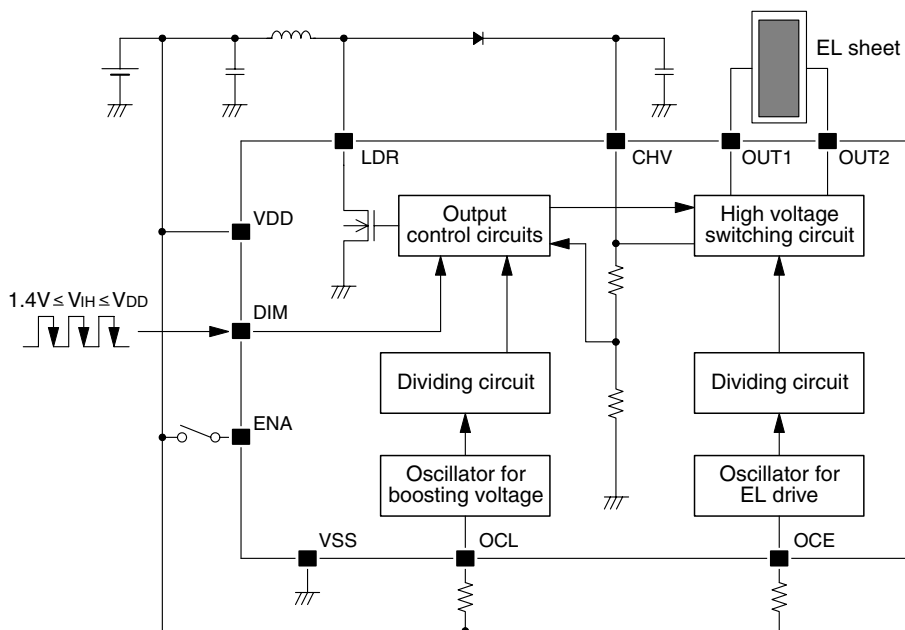

ELECTRICAL SPECIFICATIONS

Absolute Maximum Ratings

Parameter	Symbol	Conditions	Rating	Unit
Supply voltage range	V_{DD}		-0.3 to 7.0	V
Input voltage range	V_{IN}	All input pins	$V_{SS} - 0.3$ to $V_{DD} + 0.3$	V
CHV output voltage range	V_{CHV}	CHV pin	0.5 to 120	V
LDR output voltage range	V_{LDR}	LDR pin	0.5 to 120	V
OUT1/2 output voltage range	$V_{OUT1/2}$	OUT1, OUT2 pins	0.5 to 120	V
Power dissipation	P_D	$T_a \leq 85^\circ\text{C}$	100	mW
Storage temperature range	T_{STG}		-55 to 125	$^\circ\text{C}$

Recommended Operating Conditions

Parameter	Symbol	Conditions	Rating			Unit
			min	typ	max	
Supply voltage range	V_{DD2}		2.5	3.6	5.5	V
Operating temperature range	T_{OPR}		-40		85	$^\circ\text{C}$
Operating current ¹	I_{DD2}	Including coil current, $V_{DD} = 3.0\text{V}$			60	mA
		Including coil current, $V_{DD} = 5.0\text{V}$			36	
Coil inductance	L_{LDR}	$f_{LDR} = 64\text{kHz}$		220		μH

1. This value includes current tolerance and should not be exceeded.

Electrical Characteristics

$V_{DD} = 3.6V$, $V_{SS} = 0V$, $T_a = 25^\circ C$ unless otherwise noted

Parameter	Pin	Symbol	Conditions	Rating			Unit
				min	typ	max	
Output voltage	OUT1/2	V_{OUT}	V_{OUT} maximum setting	70	85	100	V
Output resistance	LDR	R_{LDR}	$I_{LDR} = 50mA$		8.0	12.0	Ω
Oscillator frequency	OCE	f_{OCE1}	$R_{OCE} = 200k\Omega$	205	256	307	kHz
Frequency variable range		f_{OCE2}		32		1536	
Oscillator frequency	OCL	f_{OCL1}	$R_{OCL} = 100k\Omega$	410	512	614	kHz
Frequency variable range		f_{OCL2}		32		1536	
Output frequency	OUT1/2	f_{OUT1}	$R_{OCE} = 200k\Omega$	200	250	300	Hz
Frequency variable range		f_{OUT2}		31		1500	
Coil drive frequency	LDR	f_{LDR1}	$R_{OCL} = 100k\Omega$	102	128	154	kHz
Frequency variable range		f_{LDR2}		8		384	
Input voltage	ENA/DIM	V_{IH}	ENA/DIM = HIGH, $V_{DD} = 2.5$ to $5.5V$	1.4			V
		V_{IL}	ENA/DIM = LOW, $V_{DD} = 2.5$ to $5.5V$			0.3	
Input current	ENA/DIM	I_{IH}	ENA/DIM = $V_{DD} = 3.6V$	3.0	6.0	9.0	μA
Rise time ¹	ENA	t_{ENA}				100	ms
Signal input frequency ²	DIM	f_{DIM}	Signal input frequency maximum value at 50% pulse duty			150	kHz
Signal input time ²	DIM	t_{DIMH}	DIM input signal HIGH-level pulsewidth minimum	3.0			μs
		t_{DIML}	DIM input signal LOW-level pulsewidth minimum	3.0			μs
Operating current	VDD	I_{DD1}	Excluding coil current		0.5	1.0	mA
Standby current	VDD	I_{STB}	ENA = LOW		0.01	1.0	μA

1. t_{ENA} is the rating between the following levels.

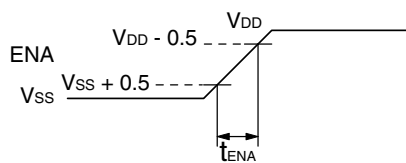

2. Design guarantee value

OPERATIONAL DESCRIPTION

EL Sheet

■ EL Emission Condition

An AC (30Hz to several kHz) high voltage (60Vp-p to several hundred Vp-p) is required for EL emission. The SM8146AD1 supports an EL drive frequency range of 31Hz to 1500Hz and an EL drive voltage range of 86Vp-p to 170Vp-p.

■ EL Life

The EL drive frequency and EL drive voltage have a simultaneous affect on the EL brightness and EL life span. The EL life decreases when the EL brightness is high, so an optimized value should be selected for the EL sheet used. The EL life also has an effect on the EL drive voltage waveform. The SM8146AD1 EL drive voltage waveform is a sine wave with small high-harmonic components which helps to extend EL life.

■ EL Audible Noise

The EL sheet has a piezoelectric characteristic that generates audible noise when excited by the applied AC high voltage. The SM8146AD1 EL drive voltage waveform is a sine wave with small high-harmonic components which helps to reduce EL audible noise. The EL drive waveform sine wave, generated by the EL drive circuit, does not require an output resistor. Consequently, peripheral components and a corresponding drop in power efficiency can be avoided.

■ EL Drive Voltage (Constant-Voltage Control and Overvoltage Protection)

The SM8146AD1 uses constant-voltage control where the EL drive voltage is set to 7 stabilized voltage amplitude levels determined by the IC internal circuitry. The EL drive voltage amplitude is initially set to the default value of 85V, and then changes in sync with the falling edge of each DIM input pulse in the continuous sequence 85V → 78V → 71V → 64V → 57V → 50V → 43V → 0V (OFF) → 85V. The EL drive voltage constant-voltage control not only eliminates EL brightness variations due to supply voltage fluctuations, but also functions as overvoltage protection when the EL load is removed.

Interface

The SM8146AD1 uses an interface comprised by the ENA and DIM input pins. The ENA and DIM pins have a HIGH-level input voltage range of 1.4V to VDD + 0.3V, enabling direct control from a 1.8V system microcontroller without the need for a voltage converter. Pull-down resistances are built-in.

■ ENA Pin

The ENA pin functions as the IC ON/OFF control. The device is enabled when ENA is HIGH, and disabled when ENA is LOW.

■ DIM Pin

The DIM pin functions as the EL brightness adjustment (dimming) control. The EL drive voltage amplitude reduces in sync with the falling edge of each DIM input pulse in the continuous sequence 85V → 78V → 71V → 64V → 57V → 50V → 43V → 0V (OFF) → 85V. The DIM pin should be connected to GND when EL brightness control is not used.

EL Brightness Adjustment

The SM8146AD1 EL brightness can be adjusted using a combination of two methods: (1) EL drive voltage control and (2) EL drive frequency control.

(1) EL Brightness Adjustment using EL Drive Voltage

This dimming function changes the EL brightness in response to the EL drive voltage determined by the number of input pulses on the DIM pin. An internal counter is used to count the number of DIM input pulses and the OUT1/OUT2 EL drive voltage amplitude level changes in response, varying the EL brightness. The 3-bit internal counter provides 8-step adjustment (DATA 0 to 7). On the 7th pulse (DATA = 7), the EL sheet is turned OFF. On the 8th pulse (DATA = 0), the voltage is set to the default value (maximum brightness). Since the default value provides the maximum brightness, the DIM pin should be connected to GND when the dimming function is not used.

Table 1. OUT1/OUT2 pins voltage amplitude and DIM pin input pulse count

DATA	0	1	2	3	4	5	6	7
DIM pin input pulse count	0	1	2	3	4	5	6	7
	8	9	10	11	12	13	14	15
	16	17	18	19	20	21	22	23
OUT1/OUT2 pins voltage amplitude	85V	78V	71V	64V	57V	50V	43V	0V

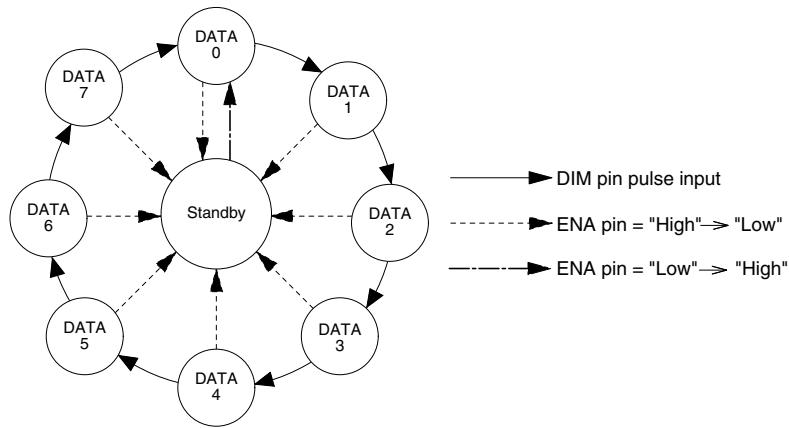

Transition diagram of IC internal state by ENA and DIM pins

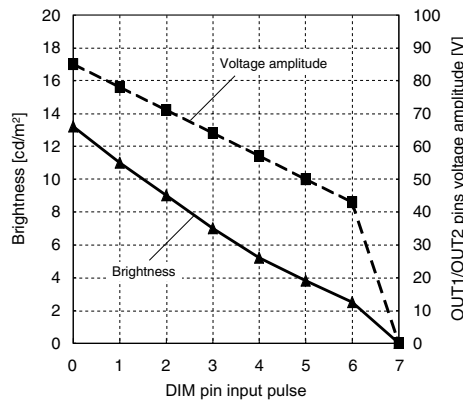

DIM pin input pulse count vs. EL brightness, OUT1/OUT2 pins voltage amplitude

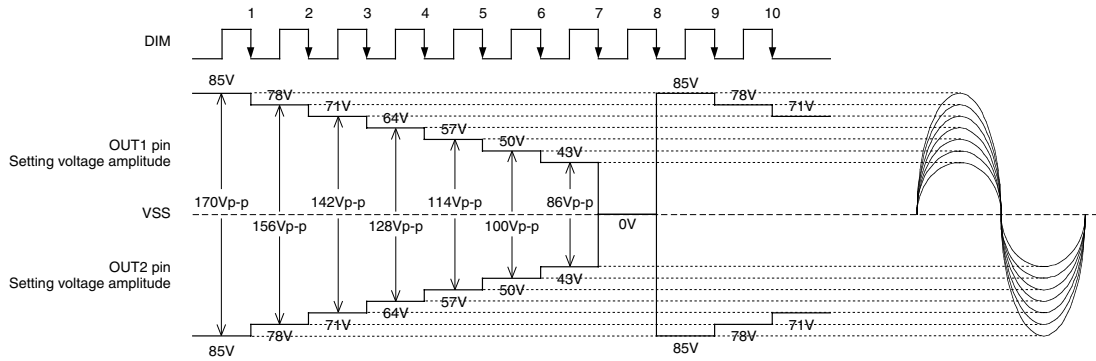

Note: Target values without compensation for voltage accuracy.

■ Input pulse to DIM pin

The pulse input to DIM pin is allowed after startup time 1msec that is for initializing IC interior with ENA pin at High level. The output voltage is setup at the initial value DATA0: 85V. The pulse input to DIM pin changes the output pin voltage setting, so that the EL brightness can be adjusted.

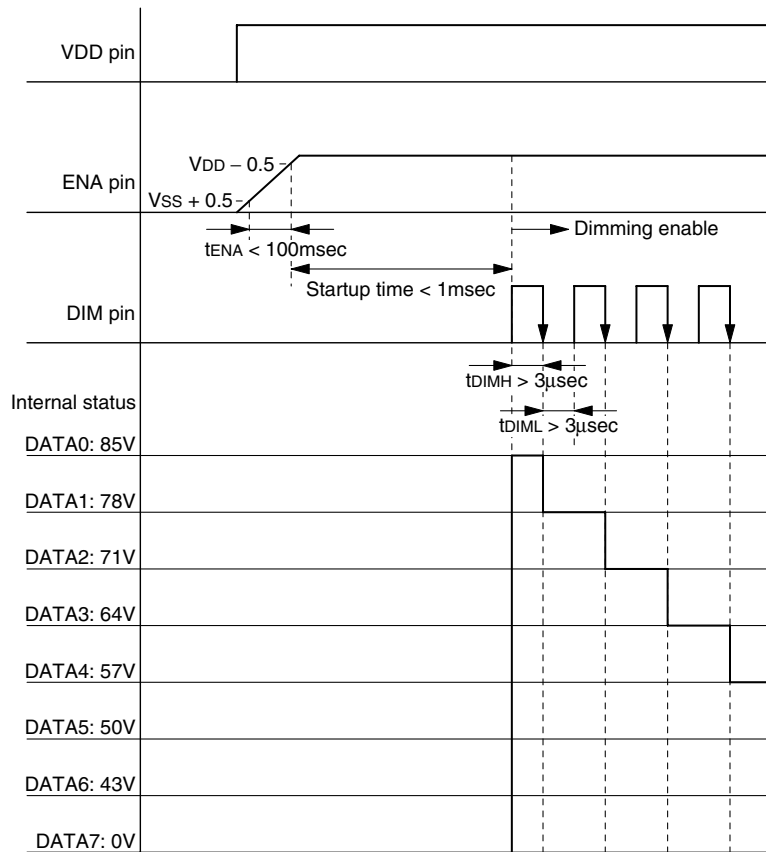

■ Method to increase EL brightness in steps (Fade-in)

The raise of output voltage in steps by the input pulse to DIM pin increases the EL brightness in steps. The timing chart is shown below. Initially the ENA pin is turned to High level, and then the pulse should be input after startup time 1msec of IC interior. Since the output voltage is setup at the initial value DATA0: 85V, when the seven times in a row of pulse are input to DIM pin, the setup value of output voltage becomes DATA7: 0V which is the first tone of fade-in. When the seven times in a row of pulse are input to DIM pin once again after the time t_{FD} , the setup value of output voltage becomes DATA7: 43V which is the second tone of fade-in. If this operation is repeated six times, the brightness becomes maximum value, thus the fade-in would be realized. The frequency of the pulse which is input to DIM pin should be set up at over several tens of kHz. This frequency is adequately higher than the EL driving frequency in order that the EL brightness does not vary during the continuous pulse input.

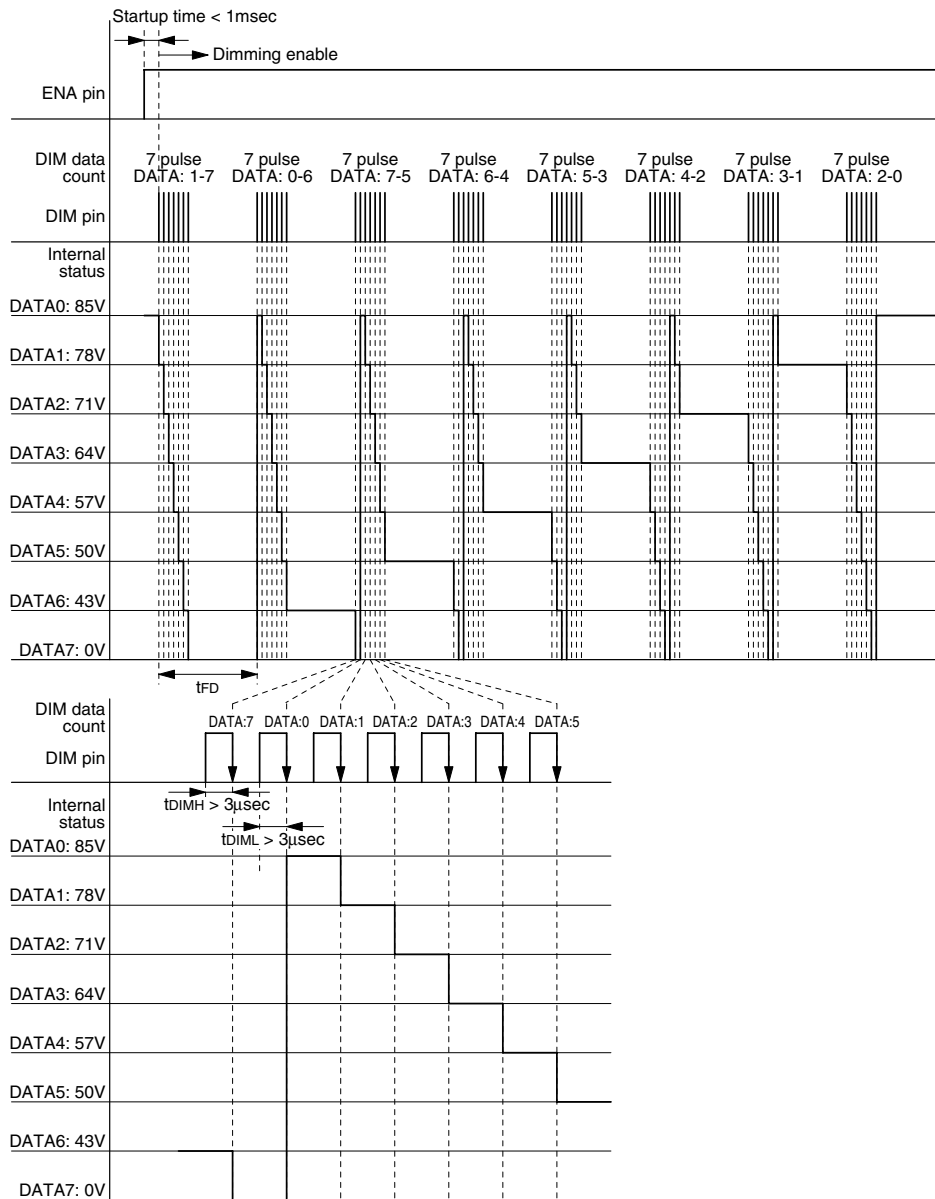

Recommended setting value: $t_{FD} = 90\text{msec}$
 $t_{DIMH} = 25\mu\text{sec}$
 $t_{DIML} = 25\mu\text{sec}$

(2) EL Brightness Adjustment using EL Drive Frequency

This dimming function changes the EL brightness in response to the EL drive frequency determined by the value of the resistance of R_{OCE} connected to the OCE pin. This dimming property should only be set when determining the peripheral components. It is not recommended to vary the EL brightness by switching the R_{OCE} resistance.

EL Output Voltage Waveform (Sine Wave) Distortion

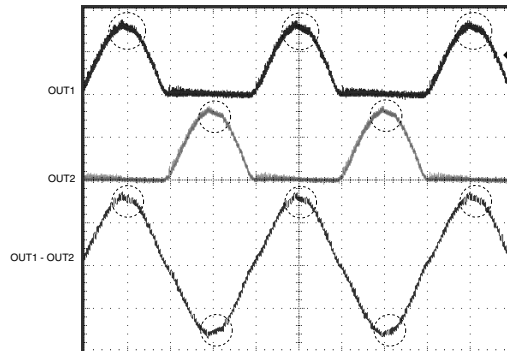

Flat regions near the waveform peaks of EL driving voltage are generated in principle of operation. They are not failure and do not affect the brightness and the audible noise.

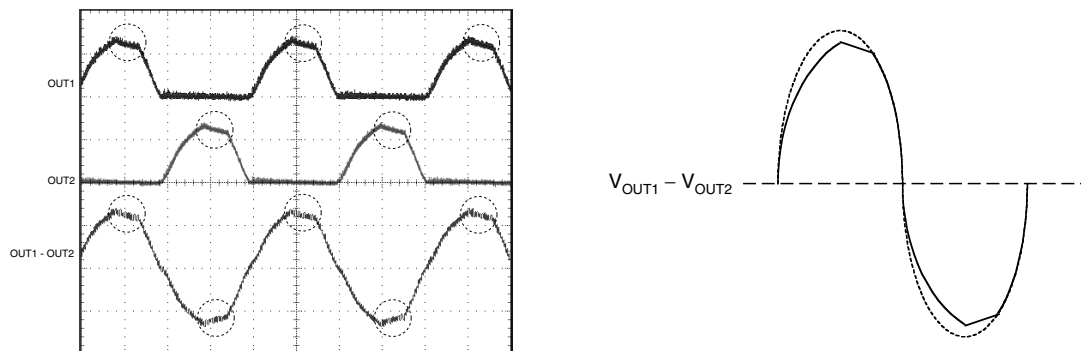

Depending on conditions, the OUT1/OUT2 output waveform may become distorted as shown by the solid line in the figure above. If the booster circuit drive capability is insufficient, the circuit may not be able to provide the boost required to meet the ideal curve shown by the dotted line in the figure above. This condition can be caused by the inductor supply voltage being too low, the inductance value being too high, the inductor frequency being too high, the EL drive frequency being too high, or the EL surface area being too large.

TYPICAL APPLICATION CIRCUIT

EL Sheet: 10cm²

Direct power supply from Li-ion secondary battery

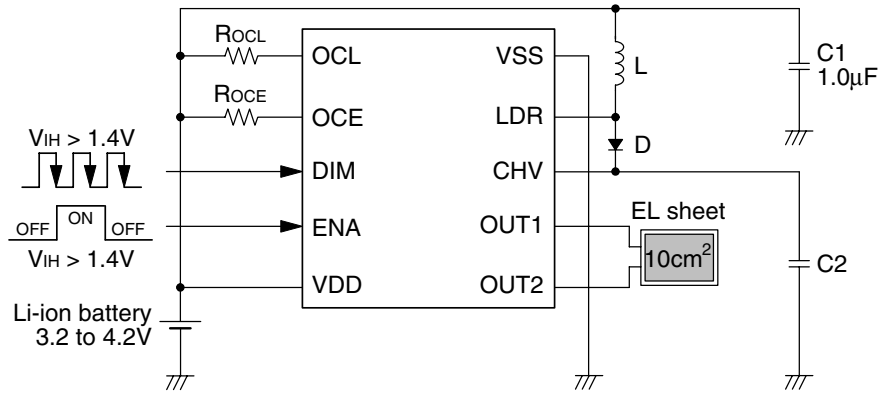

D : TOSHIBA 1SS403
 L : TAIYO YUDEN NR4012T221M
 C2 : MURATA GRM3192C2A222JA01

V _{DD} [V]	I _{DD} [mA]	L [μH]	R _{OCL} [kΩ]	R _{OCE} [kΩ]	f _{OUT} [Hz]	V _{OUT} [V]	Brightness [cd/m ²]	Other component
3.2 to 4.2	Figure 1	220	220	150	345	Figure 2	Figure 3	-
				120	420			-
				100	500			-

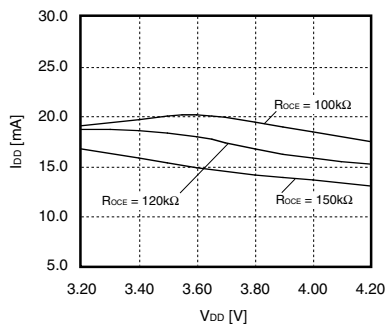

Figure 1. V_{DD} VS. I_{DD}

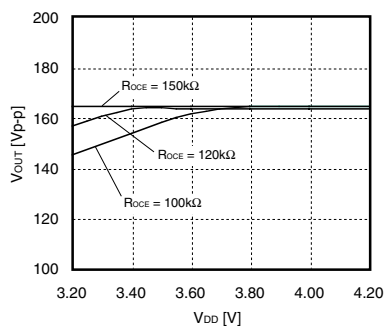

Figure 2. V_{DD} VS. V_{OUT}

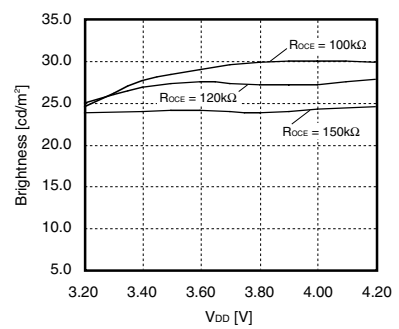
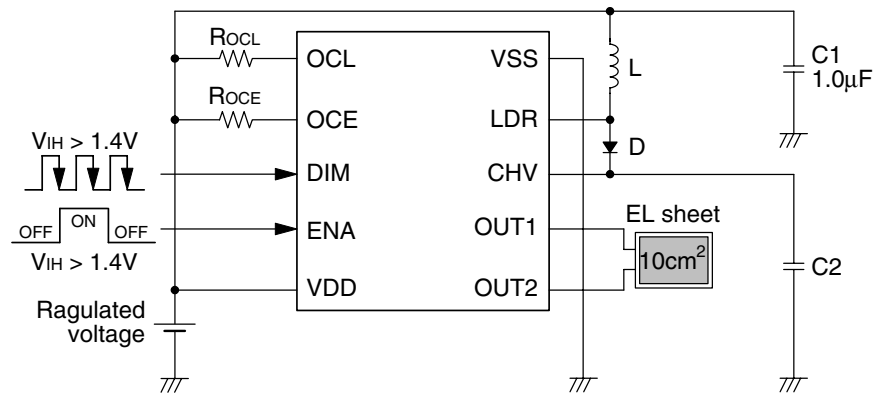

Figure 3. V_{DD} VS. Brightness

Power supply from stabilizing supply



D : TOSHIBA 1SS403
 L : TAIYO YUDEN NR4012T221M
 C2 : Refer to the table below

V _{DD} [V]	I _{DD} [mA]	L [µH]	R _{OCL} [kΩ]	R _{OCE} [kΩ]	f _{OUT} [Hz]	V _{OUT} [V]	Brightness [cd/m ²]	Other component
3.0	17.4	220	390	200	262	165	19.5	C2: GRM3192C2A222JA01
3.3	20.6		330	130	392	165	26.1	C2: GRM3192C2A222JA01
4.0	20.0		220	91	538	165	31.5	C2: GRM3192C2A222JA01
5.0	15.5		110	91	541	165	32.2	C2: GRM3192C2A472JA01

EL Sheet: 20cm²

Direct power supply from Li-ion secondary battery

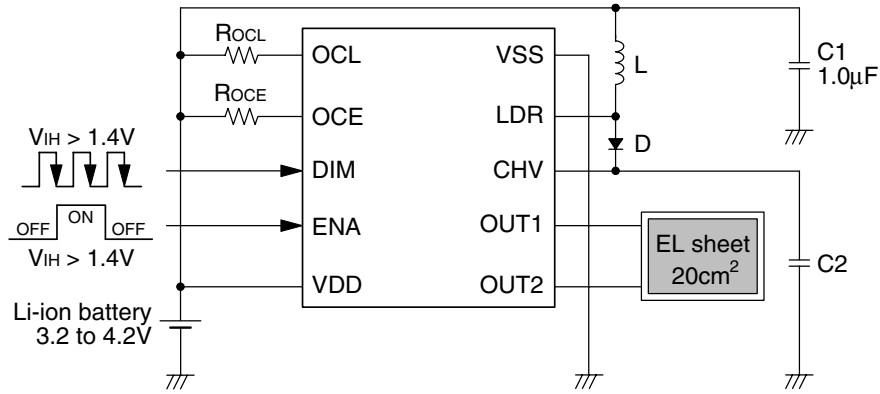

D : TOSHIBA 1SS403
 L : TAIYO YUDEN NR4012T221M
 C2 : MURATA GRM3192C2A222JA01

V _{DD} [V]	I _{DD} [mA]	L [µH]	R _{OCL} [kΩ]	R _{OCE} [kΩ]	f _{OUT} [Hz]	V _{OUT} [V]	Brightness [cd/m ²]	Other component
3.2 to 4.2	Figure 1	220	220	270	198	Figure 2	Figure 3	-
				220	241			-
				180	288			-

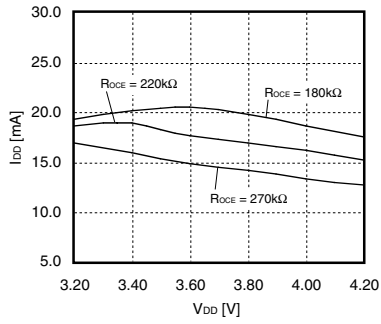

Figure 1. V_{DD} VS. I_{DD}

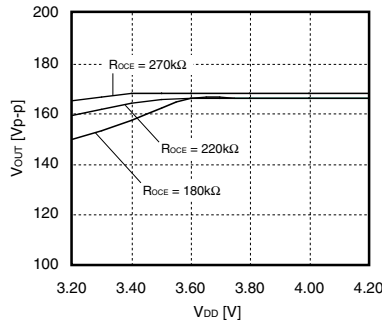

Figure 2. V_{DD} VS. V_{OUT}

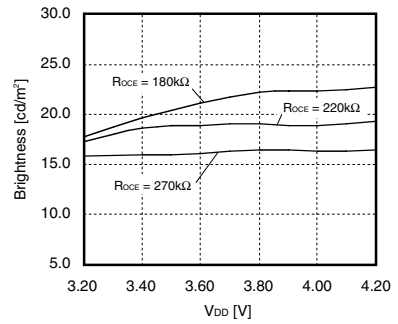
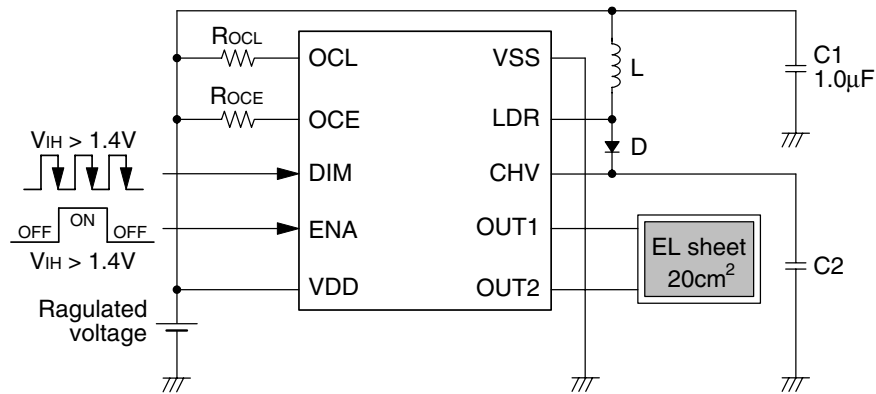

Figure 3. V_{DD} VS. Brightness

Power supply from stabilizing supply



D : TOSHIBA 1SS403
 L : TAIYO YUDEN NR4012T221M
 C2 : Refer to the table below

V _{DD} [V]	I _{DD} [mA]	L [µH]	R _{OCL} [kΩ]	R _{OCE} [kΩ]	f _{OUT} [Hz]	V _{OUT} [V]	Brightness [cd/m ²]	Other component
3.0	21.0	220	390	300	177	165	15.4	C2: GRM3192C2A222JA01
3.3	20.9		330	240	221	165	18.3	C2: GRM3192C2A222JA01
4.0	19.2		220	180	291	165	22.0	C2: GRM3192C2A222JA01
5.0	20.2		160	120	423	165	28.2	C2: GRM3192C2A472JA01

EL Sheet: 30cm²

Direct power supply from Li-ion secondary battery

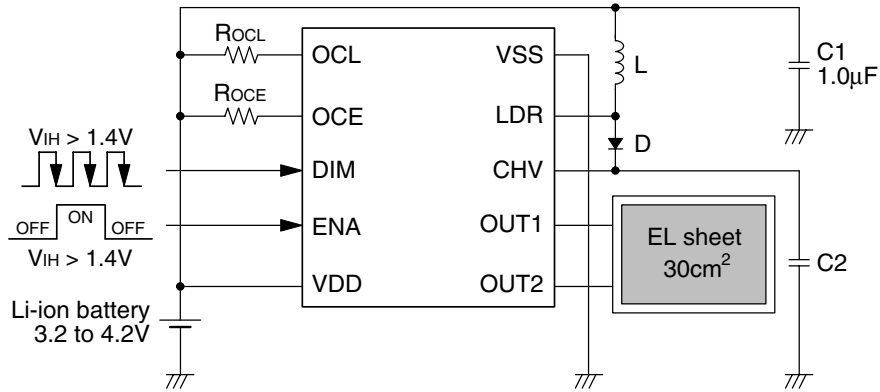

D : TOSHIBA 1SS403
 L : TAIYO YUDEN NR4012T221M
 C2 : MURATA GRM3192C2A332JA01

V _{DD} [V]	I _{DD} [mA]	L [µH]	R _{OCL} [kΩ]	R _{OCE} [kΩ]	f _{OUT} [Hz]	V _{OUT} [V]	Brightness [cd/m ²]	Other component
3.2 to 4.2	Figure 1	220	220	430	125	Figure 2	Figure 3	-
				330	162			-
				300	182			-

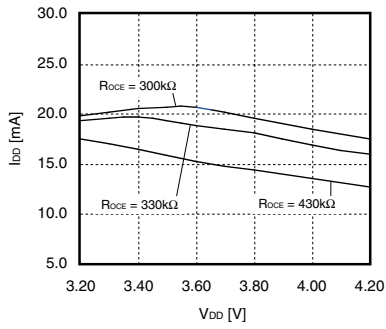

Figure 1. V_{DD} VS. I_{DD}

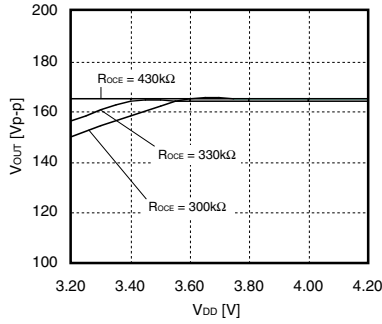

Figure 2. V_{DD} VS. V_{OUT}

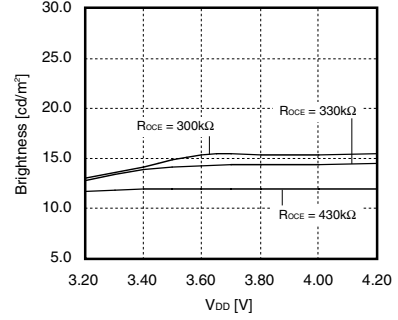
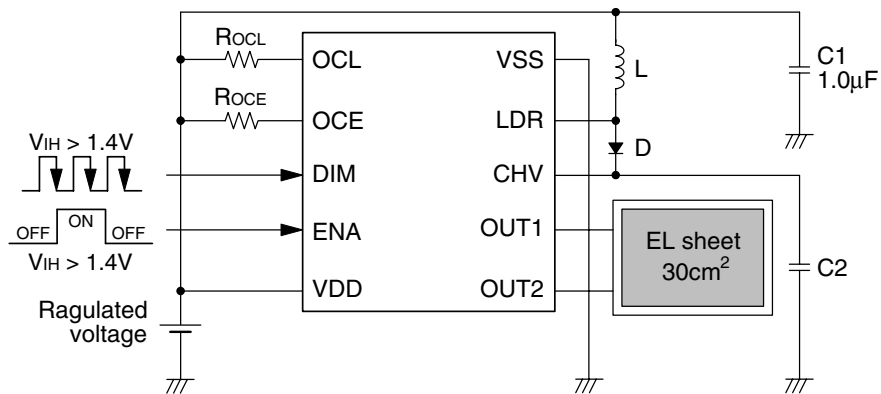

Figure 3. V_{DD} VS. Brightness

Power supply from stabilizing supply



D : TOSHIBA 1SS403
 L : TAIYO YUDEN NR4012T221M
 C2 : Refer to the table below

V _{DD} [V]	I _{DD} [mA]	L [µH]	R _{OCL} [kΩ]	R _{OCE} [kΩ]	f _{OUT} [Hz]	V _{OUT} [V]	Brightness [cd/m ²]	Other component
3.0	18.4	220	390	560	97	165	9.8	C2: GRM3192C2A222JA01
3.3	20.5		330	390	138	165	12.6	C2: GRM3192C2A222JA01
4.0	20.8		220	270	199	165	16.5	C2: GRM3192C2A472JA01
5.0	20.8		160	180	291	165	21.5	C2: GRM3192C2A472JA01

PERIPHERAL COMPONENT SELECTION

Coil

Booster coil. Where possible, a closed-magnetic circuit type coil should be selected. If the coil inductance is less than 100 μ H, the switching cannot keep pace and the brightness cannot be increased. The coil flowing into the coil is a sawtooth waveform, and care should be taken to ensure the peak current does not exceed the maximum current rating. The coil DC resistive component causes power loss, so a coil with low DC resistive component is advantageous. The recommended inductance is 100 to 470 μ H.

Table 2. Recommended parts list (Attention: R_{OCL} and R_{OCE} should be optimized per inductor.)

Manufacture	Part number	Inductance [μ H]	Dimensions [mm]		
			W	L	T
TAIYO YUDEN	NR4012T221M	220	4.0	4.0	1.2
	NR3010T101M	100	3.0	3.0	1.0
MURATA	LQH3NPN221NG0	220	3.0	3.0	1.0
	LQH3NPN151NG0	150	3.0	3.0	1.0
	LQH3NPN101NG0	100	3.0	3.0	1.0
	LQH32CN221	220	3.2	2.5	2.0
TDK	VLS3012T-101MR23	100	3.0	3.0	1.2
TOKO	1156AS-221M	220	2.85	2.8	1.0
	1156AS-151M	150	2.85	2.8	1.0
	1156AS-101M	100	2.85	2.8	1.0
	888FU-221M	220	3.5	3.5	1.7

Diode

Rectifier diode. This diode rectifies the high voltage generated by the coil. The peak reverse voltage exceeds 100V, hence a fast recovery type diode is recommended.

Table 3. Recommended parts list

Manufacture	Part number	Dimensions [mm]		
		W	L	T
TOSHIBA	1SS403	1.7	1.25	0.9
ROHM	RF051VA2S	1.9	1.3	0.6
	RF071M2S	2.6	1.6	0.8

High-voltage capacitor

Smoothing capacitor. This capacitor smooths the high voltage generated by the coil and rectified by the diode. A withstand voltage rating of ≥ 100 V should be selected. Generally, a high-dielectric ceramic capacitor will generate audible noises. The capacitors below are recommended. The recommended value is 0.0022 to 0.0033 μ F (100V).

Table 4. Recommended parts list

Manufacture	Part number	Capacitance [μ F]	Dimensions [mm]		
			W	L	T
MURATA	GRM3192C2A222JA01	0.0022	3.2	1.6	0.85
TDK	C2012CH2A222	0.0022	2.0	1.25	0.85
Panasonic	ECWU1222JX5	0.0022	3.2	1.6	1.1

ELECTROSTATIC BREAKDOWN PROTECTIVE MEASURES (ESD)

Electrostatic breakdown protective measures are required because the keypad comes into direct contact with the human body. The EL sheet surface is coated with an insulating film, but if the electrodes on the EL sheet periphery are exposed, static electricity can flow from these electrodes into the IC and lead to electrostatic breakdown. Accordingly, the EL sheet should be designed so that the electrodes are not exposed, or otherwise covered using insulating tape to provide a similar level of protection.

EVALUATION BOARD PATTERN

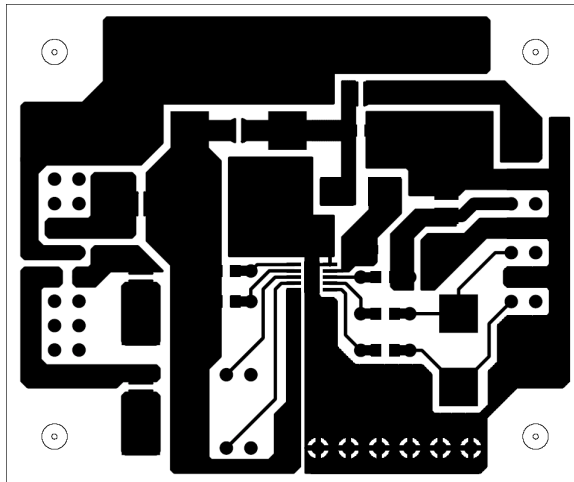

Pattern (Top view)

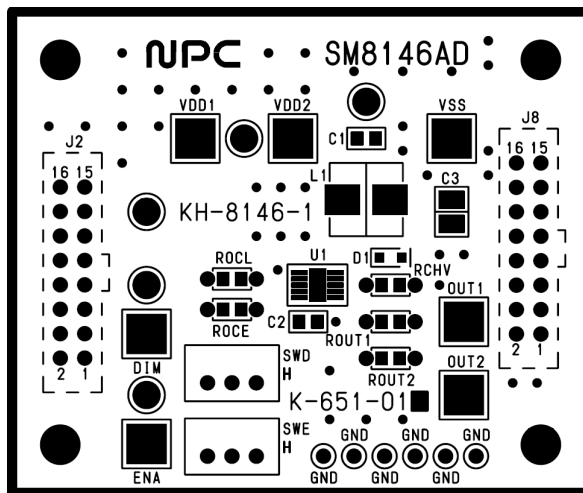

Silk + Resist (Top view)

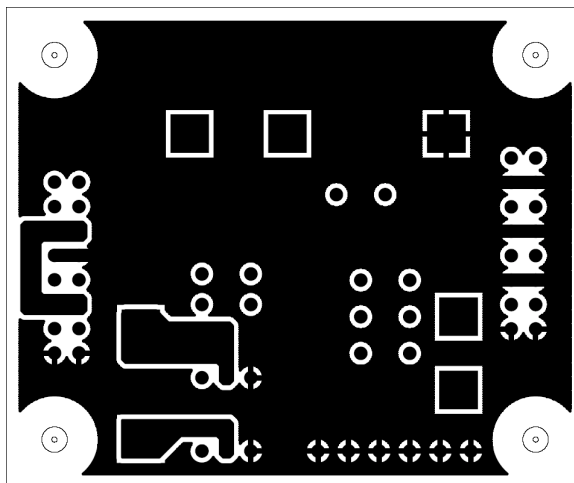

Pattern (Bottom view)

PACKAGE DIMENSIONS

(Unit: mm)

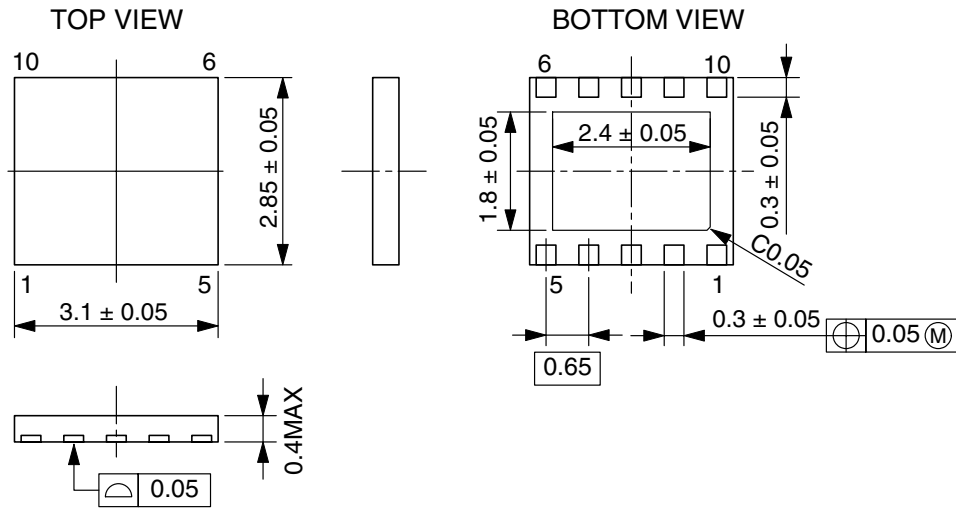

FOOTPRINT

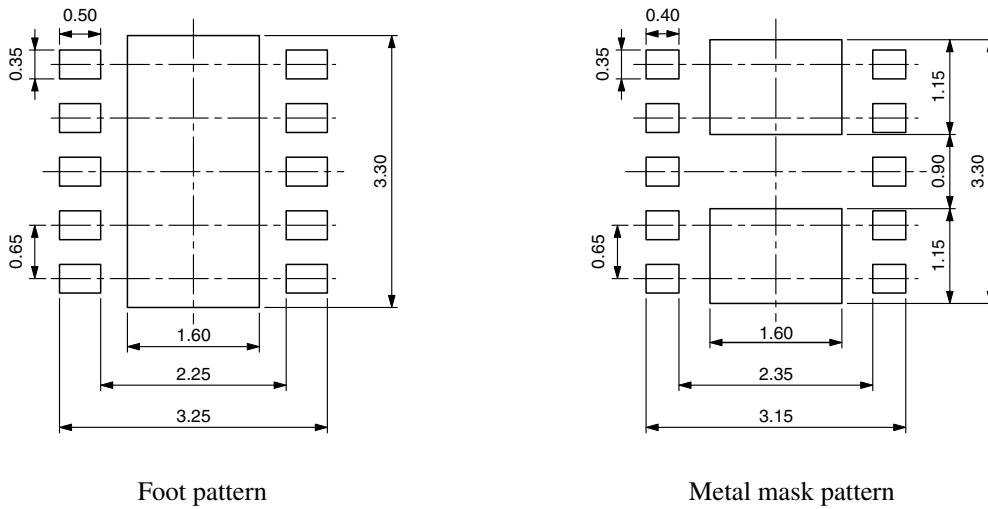

Please pay your attention to the following points at time of using the products shown in this document.

The products shown in this document (hereinafter "Products") are not intended to be used for the apparatus that exerts harmful influence on human lives due to the defects, failure or malfunction of the Products. Customers are requested to obtain prior written agreement for such use from SEIKO NPC CORPORATION (hereinafter "NPC"). Customers shall be solely responsible for, and indemnify and hold NPC free and harmless from, any and all claims, damages, losses, expenses or lawsuits, due to such use without such agreement. NPC reserves the right to change the specifications of the Products in order to improve the characteristic or reliability thereof. NPC makes no claim or warranty that the contents described in this document dose not infringe any intellectual property right or other similar right owned by third parties. Therefore, NPC shall not be responsible for such problems, even if the use is in accordance with the descriptions provided in this document. Any descriptions including applications, circuits, and the parameters of the Products in this document are for reference to use the Products, and shall not be guaranteed free from defect, inapplicability to the design for the mass-production products without further testing or modification. Customers are requested not to export or re-export, directly or indirectly, the Products to any country or any entity not in compliance with or in violation of the national export administration laws, treaties, orders and regulations. Customers are requested appropriately take steps to obtain required permissions or approvals from appropriate government agencies.

The logo for NPC (Seiko NPC Corporation) consists of the letters 'NPC' in a bold, black, sans-serif font. The 'N' and 'P' are connected at the top, and the 'C' is positioned to the right of the 'P'.

SEIKO NPC CORPORATION

15-6, Nihombashi-kabutocho, Chuo-ku,
Tokyo 103-0026, Japan
Telephone: +81-3-6667-6601
Facsimile: +81-3-6667-6611
<http://www.npc.co.jp/>
Email: sales@npc.co.jp

NC0616BE 2007.09